

12/2016

Mod: DLW40-TS/D

Production code: S40DDIELS8AIA



Diamond
laundry equipment

Index

1. INTRODUCTION	3
2. SAFETY RULES.....	3
3. MANUFACTURER RESPONSABILITY	4
4. UNPACKING	4
5. INSTALLATION AND PLACING.....	5
6. MACHINE IDENTIFICATION	5
7. NOISE.....	5
8. GROUND FIXING.....	5
9. ELECTRIC CONNECTION.....	7
10. HYDRAULIC CONNECTION: LOAD.....	8
11. HYDRAULIC CONNECTION: DRAIN	8
12. STEAM CONNECTION	8
13. COMPRESSED AIR CONNECTION.....	9
14. MASCHINE START AND FINAL TEST.....	9
15. LANGUAGE CHANGE	9
16. REMOTE ASSISTANCE SERVICE ACTIVATION.....	10
17. WASHING MACHINE USE	10
18. LINEN PREPAIRING.....	11
19. HOW TO LOAD THE MACHINE AND CLOSE THE DOOR	12
20. DOOR MANUAL OPENING	12
21. MACHINE SWITCH ON	12
22. SELECT A PROGRAM.....	13
23. PREFERRED PROGRAM LIST	13
24. DELAYED START	13
25. PROGRAM EXECUTION	14
26. PROGRAM PAUSE	14
27. RAPID ADVANCE	14
28. END OF WORKING DAY	15
29. PROGRAM	15
30. PROGRAM MODIFICATION.....	15
31. EASY PROG.....	17
32. SELF DIAGNOSTICS.....	19
33. PROGRAM SET BY THE FACTORY.....	21
34. OTHER FUNCTION	22
35. WASHING MACHINE MAINTENANCE	22
36. WASHING DEFECTS.....	22
37. TILTING MACHINE USE.....	22
38. SAFETY DEVICES CONTROL	23
39. SCRAPPING	23
40. WARRANTY CONDITIONS	24

1. INTRODUCTION

This manual is addressed to explain industrial washing machine use.

It is written in compliance with actual EU directives.

The information here written is addressed to the installer and to the user, which must fully understand them before to work on the machine.

The user manual must always be available to be consulted. In case of missing or damaging of the manual, ask to the manufacturer for a new copy.

The manufacturer is not responsible for any consequence coming from a not correct use of the machine because of a misreading or a not complete reading of this manual.

The manufacturer reserves itself the right to modify the here written machine specification or characteristic without any previous notice. The pictures of this manual may differ from reality for some detail, which could be partially different from the one mounted on the machine. Diagram and technical data may be modified without any previous notice.

The manual and its attachment are part of the manual themselves, so they must be kept and they must follow the machine in case of sale to another user.

Attachments and exploded view with spare parts list can be retrieved in IMESA web site restricted area. Before to access to the manufacturer technical area be sure that the machine serial number is available.



ATTENTION!

The manufacturer declines any responsibility about possible errors contained in this manual because of printing, translation or writing imprecision.

The manufacturer reserves itself the right to make any necessary modification to the machine without affecting any machine essential characteristic.

It is forbidden the copying, also partially, of the text or of the pictures of this manual without any previous manufacturer authorization.

2. SAFETY RULES

The missing observance of the below safety rules may cause damages to people, things and animals.

The here described machines installation and maintenance must be done by authorized personnel, who know the product and in compliance with EU directives of sector.

Reparation made in a not correct way may be dangerous for the user.

Before to put in service the machine, this instructions must be read with high attention. This

document must be available to everyone is using the machine.

The here described machine are addressed to the professional washing of garments and linen: it is forbidden any other use of the machine if not previously authorized by the manufacturer.

Do not washed linen soaked with substances which are dangerous for the user health like poison or cancerous products.

Do not approach the machine with combustible or inflammable substances to avoid the risk of fire or explosion.

Always stick to the washing instructions of the linen label.

The use of this machine is forbidden to people under 16 years age.

Not properly done external connection to the machine release the manufacturer from any responsibility.

IMPORTANT NOTES

Working with opened sides is forbidden!



In order to avoid burnings or accident it is forbidden to remove, even temporarily, the protection panels and the safety systems!

It is forbidden to introduce bars, sticks or metallic objects inside the drum. In case of emergency, please refer always the here described procedures.

Each time the machine is started, check always the safety device correct working!

It is compulsory to know the machine and how its safety devices are working!



BURNS DANGERS

The machine, because of its nature, presents burns danger.

Burns may be caused by:

- **A long contact with door during a high temperature program;**
- **The contact with the fluxing steam parts.**

On the machines are fixed the following labels, if one of them should be damaged, the user must replace it with a new identical one.



Near the door



Machine must always be used by trained personnel and with at least one other operator in the room!

READ CAREFULLY THE INSTRUCTION FOR OPERATING IN CASE OF BLACK OUT, AND INFORM ALL THE USERS ABOUT THEM.



ELECTROCUTION DANGER

Any service on the electrical parts must be operated only by qualified personnel. Before to work on the machine, cut off the electrical supply.

Power and controlled circuits can be modified only by manufacturer personnel, on the contrary the warranty condition empire.

On the electric board, the here below warning label was stuck. If this label should be damaged or unstuck, it needs to be replaced by an identical one.

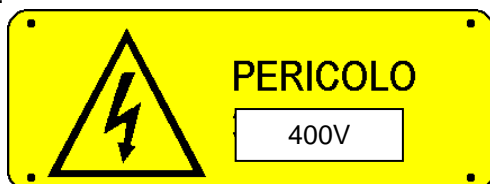

OPERATOR PSYCHO-PHYSICAL CONDITIONS

People using the machine must be in a perfect psycho-physical condition; during the working cycle, the user must always assume a vertical posture in front of the machine.

Suddenly or not controlled movement must be

avoided because of the risks of dangerous knocks against the washer chassis, i.e.: during the dryer unloading.

The other people in the laundry room do not have to distract the operator, who is working on the dryer.

While working, the operator does not have to be distracted by TV, radio or any source of distraction.



ILLUMINAZIONE LIGHTING

In the room where the machine is installed, the lighting must be at least of 300-500 lux intensity; unpleasant flashing must be avoided.



ATTENTION!

These instructions do not cover all possible risks. User must always pay high attention and respect carefully the rules.

3. MANUFACTURER RESPONSABILITY

The instructions written in this manual are not replacing, but completing the duties deriving from the safety and accident prevention laws. With reference to what is written in this manual, the manufacture is not responsible for:

- a use of the machine against the safety and accident prevention laws in force.
- not correct machine installation.
- missing of periodical and programmed maintenance.
- not observance, or not correct observance, of this manual instructions.
- electrical supply fault.
- not authorized modification of the machine.
- use of the machine by not authorized personnel.

4. UNPACKING

The machine must be controlled at the delivery moment, any external or inside damage dues to the transport, must be reported immediately to the forwarder.

The machine must be completely unpacked next to the installation position. The packing material must not be spread on the environment, but must be collect in the appropriate collecting place as per the environmental directives.

Using a monkey spanner, take off the bolts fixing the machine to the pallet.



ATTENTION!

Check the technical data sheet, which is sent together with the machine documents, to control

the net and gross weight: check if they meet the data of the available lifting means.



ATTENTION!

The pallet must not be used as a normal machine support! Always take down the machine from the pallet. Install the machine as described in the opposite paragraph.



ATTENTION!

The machine must be moved only when it is still fixed on its pallet and, in case of forklift truck, only by authorized personnel.

During the transport, the high spin washing machines base and cradle are blocked with locks in order to avoid shock absorber stress.



ATTENTION!

Transport locks need to be removed once the machine is positioned and before it is supplied.

To take off the transport locks, follow the next instructions. Pictures indicate the lock type, not the machine.

- Remove frontal and rear panels.
- Unscrew the bolts fixing the transport locks.
- Remove the transport locks
- Mount again the panels in the original position.

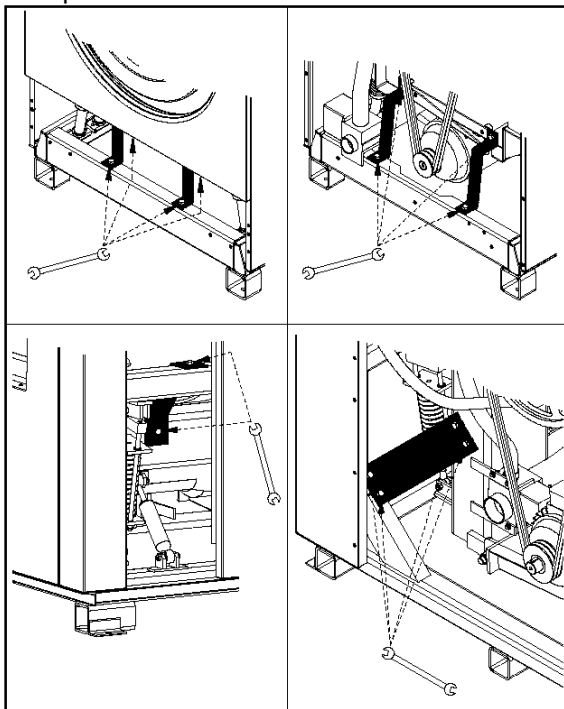

Each panel must be mounted again in the original position before the machine is switched on.

When removed, the locks need to be kept and used again each time the machine needs to be moved.

Transport locks are not present in hard mounted machines.

5. INSTALLATION AND PLACING

Any placing and installation action needs to be made only by qualified personnel and respecting the instructions given in the installation manual.

To assure a correct machine use and working and to make easier the maintenance, a at least 600mm free space need to be left all around the machine.

In case of installation of machine in line, like in a coin op shop, the side space can be reduce to 10mm.

Room temperature must be between +5°C and +40°C. The room where the machine is installed need to have a sufficient air recycle.



ATTENTION!

DO not use or stock near the machine petrol, oil or any other inflammable stuff. Fire or explosion may be caused.



ATTENTION!

In case of tilting machine, machine element may be in movement during the linen loading and unloading operation.

Refer to the technical data sheet to control the overall dimension of the parts in movement during the different position.

6. MACHINE IDENTIFICATION

The machine is identified by a sticker with the machine serial number, model together with other information i.e. power and technical characteristics. The label is stuck on the machine back.

Be sure that any supply (electric, hydraulic, steam and compressed air) matches with the label data.

Spare parts and / or servicing need the correct model individuation.

Warranty automatically expires if the sticker is damaged, removed, missing or not readable. In one of these condition installation and servicing operation may be difficult because of the machine cannot be correctly identified.

7. NOISE

The air noise produced by the machine gives an acoustic pressure continued and weighted of level A below 72 dB.

8. GROUND FIXING

High spin washing machine with capacity up to 23Kg do not need any ground fixing. Machines are supplied with rubber feet which need to be screwed to the threaded holes on the machine

base.

A wrong adjusting of the feeds may cause strong vibration of the machine external structures. The machine must be installed in a perfect level on a floor without any elastic reaction.

High spin washing machine starting from 30 kg capacity must be fixed on the ground using four Fischer wall plugs and making them pass through the holes on the machine base. Machines need to be installed in a perfect level on a floor without any elastic reaction.



ATTENTION!

Do not insert any elastic stuff between the machine base and the floor.

Low spin washing machines must be ground fixed.

Starting from 30 Kg capacity, low spin washing machines are supplied with an iron frame.

- The frame must be let into a concrete base, which is opportunely anchored to the floor.
- Before to anchor the machine to the base, be sure that the concrete set well to the ground and, very important, be sure that the frame is perfectly in level.
- Place the machine in the suitable anchor holes and close all the bolts.

To control frame and concrete base dimension, check the machine technical sheet.

Up to 23Kg capacity, the washing machine are supplied with iron anchor screw.

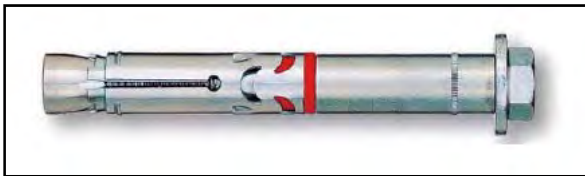

iron anchor screw

Tools necessary for installation are:

- Hammer or electro-pneumatic drill
- Hammer
- Pump for cleaning
- Brush
- Dynamometrical spanner

Please, follow the below described procedure:

- Make a concrete base which need to be well anchored to the floor, respect the technical data sheet specification;
- Be sure that the concrete base is well set to the ground, the surface need to be perfectly in level.
- Bring down the machine from the pallet and place it in the final position on the concrete base.
- Through the open panels, mark on the concrete base the position of the anchor

screws.

- Move the machine to make free the area to make the holes.
- Make the holes (see the picture) where the position is marked, and following the data of the next table.

Lt	Anchor screw length	138	mm
S	Fixable object thickness	25	mm
Øf	Drill diameter	18	mm
P	Minimum hole depth	140	mm
Hv	Anchor minimum hole	80	mm
Ch	Key	19	-
M	fixing couple	80	Nm
-	thread	M12	-

- Extract the concrete residual from the hole using a brush, using a pump make free the hole from the residual dust.
- Place again the machine matching the washing machine base hole with the concrete base holes.
- Introduce the anchor bolts through the washing machine base holes inside the concrete base holes.

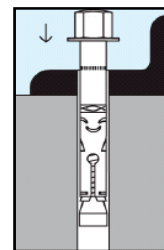

- Using a dynamometric spanner close the anchor screw following the data in the above table.



ATTENTION!

Each installed low spin machine must be

tested with a full load spin (max speed and max load), to check if:

- There is no vibrations
- There is no noise
- There is contact or sliding point between the drum and the outer drum.

IMPORTANT: if one of the above listed problems occurs, then the machine is not correctly installed. Check if:

- The concrete base is correctly at level
- The concrete base is well set to the floor
- The iron anchor screws are correctly closed.

9. ELECTRIC CONNECTION

The electrical connection must be realized by qualified personnel and it must comply with the local and national regulation in force.



ATTENTION!

Be sure that the supplied tension matches with the one indicated on the machine label.

To connect the machine use a H05 VV – F cable or superior, it must be correctly dimensioned following the data label.

Install before the machine a omnipolar disconnecting device (i.e.: a circuit breaker) which need to have a contact opening that allows the complete disconnection in case one of the conditions of the over tension III category is verified. This device must comply with the subject regulation in force.

Check the main switch, it must be in position “0”. Open the electric supply door.

Pass the electric supply cable through the cable holder supplied with the machine. The cable must be correctly dimensioned (check the following table).

Il collegamento dei cavi di alimentazione elettrica deve essere eseguito sul sezionatore di bordo macchina.

Following the kind of voltage written on the machine label, connect the cable to the knife switch contacts, following the below instructions:



: ground bolt

L1, L2, L3: phase contact

N: neutral

At the installation, or in case of replacing, the ground cable must be at least 5 cm longer than the others



ATTENTION!

The machine must be connected to an efficient ground system: the manufacturer refuse all responsibility in case this connection is not made following the subject regulation in force.

Before to start any service, cut the electric supply to the machine: for maintenance refer to the electric diagram inside the machine. The electric diagram can be retrieved from manufacturer web site.

Minimum section for supply cable or ground cables, expressed in mm² are the following:

CAPACITY		1ph 208V-240V	3ph 208V-240V	3ph 380V-440V
Low spin	6 8	6	4	
High spin				
Low spin	11 14	10	6	4
High spin				
Low spin	18	16	10	6
High spin		NO		
Low spin	23	16	10	6
High spin		NO		
Low spin	30		NO	16
High spin				
Low spin	40	NO	25	10
High spin				
Low spin	55 70	NO	25	16
High spin				

Electric heating or electric / steam heating (mm²)

CAPACITY		1ph 208V-240V	3ph 208V-240V	3ph 380V-440V
Low spin	6 8	2,5	2,5	
High spin				
Low spin	11 14	2,5	2,5	
High spin				
Low spin	18	NO	2,5	
High spin				
Low spin	23	2,5	2,5	

CAPACITY		1ph 208V-240V	3ph 208V-240V	3ph 380V-440V	
High spin	30	NO	4		
Low spin					
High spin					
Low spin					
High spin	40		6		6
Low spin					
High spin					
Low spin					
High spin					
Low spin					
High spin	55		10		
Low spin					
High spin					
Low spin					
High spin	70	10			
Low spin					
High spin					
Low spin					
High spin	85				
Low spin					
High spin					

Steam or Hot Water heating (mm²)



ATTENTION!

The minimum sections written in the above tables can be change in function of the cable length. For cable longer than 5 mt, increase proportionally the section in respect of the additional length.



ATTENTION!

The machine connection must always be done on the base of the serial number label (power, supplied tension, frequency). For supplied tension different from the one provided, please contact the manufacturer.



ATTENTION!

All washing machines are equipped by a speed control operated by an inverter: a protection through RCD – B kind device must be provided (sensitive to average current value).



ATTENTION!

In case the electrical supply come from a diesel generator, then the inverter ask for the application of an additional inductor.

10. HYDRAULIC CONNECTION: LOAD

The washing machines are equipped with electrovalve for the cold and hot water loading (in

case it is requested, the machine is equipped with a third electrovalve for hard water). Each water inlet is identified, for connection quotes refer to technical data sheet.

At the beginning of each hydraulic supply a gate valve must be provided to cut the water supply to the machine at any moment, in case of emergency or in case of service.

At the beginning of each water inlet an inspect filter must be provided. It is necessary, also, to control the machine inlet valve filter after a short time of use, overall the hydraulic system is old or not used from a long time.



ATTENTION!

All the inlet valve must always be connected! If in the supply system it is not available the hot water, connect cold water also to the inlet valve called “HOT WATER”.

When more washing machine are connected to the same water line, the water line must have a diameter sufficient to grand a water flow enough to supply all the machine in case all of them are loading water.

A minimum pressure of 0,4 atm is necessary to load the water: if the supplied pressure is lower, the water loading time are longer.

Maximum water loading pressure is 8 Atm (the minimum and maximum values are taking in consideration all the kind of valve mounted on the different machine size).

11. HYDRAULIC CONNECTION: DRAIN

The electric drain valve used are a normally open kind, it means that the water is drained in case of black out.

In case of more washing machines connected to the same drain line, it must be enough to allow the correct water flow in case all the machines are draining water at the same time.

Drain collector must avoid that the water drained by one machine enter in the next one.

The washing machine drain is for gravity, the drain tube must not present sinking or counterslope. A 2% slope must be provided to allow a correct water flow.

The drain system must satisfy the local or national laws and regulation in force.

12. STEAM CONNECTION

In case of machine steam heated a steam connection must be provided.

The steam connection must be operated by qualified personnel and must satisfy the local and national rules in force. Check that the steam has the same characteristics written in the technical data sheet and that all the system parts are certified.

The steam trap is delivered with the machine, but not mounted on the machine: the steam trap electrical and hydraulic connection is at installer charge.



ATTENTION!

Once the steam trap is connected to the machine, it must be protected by the supplied iron box: see the following picture.

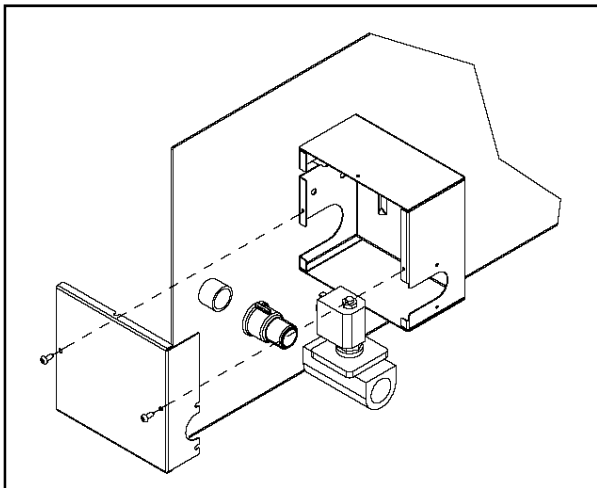

The supply steam system must be realized following the next diagram. Each connection between the system and the equipment must be tightness tested.

- A) machine
- B) external system
- C) steam supply system

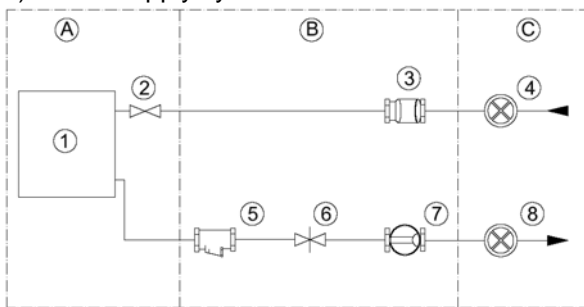

Indirect steam heating

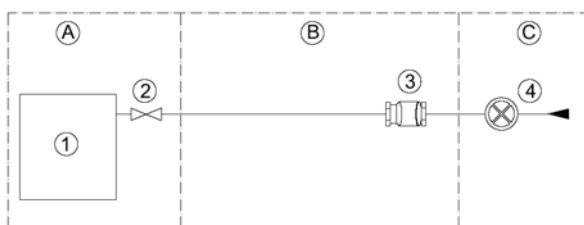

Direct steam heating

System elements are identified as follow:

- 1) washing machine
- 2) inlet steam valve(supplied with the machine)
- 3) filter

- 4) inlet steam gate valve
- 5) steam trap
- 6) check valve
- 7) flow control
- 8) exit gate valve



ATTENTION!

The machine can work with a steam pressure between 0,5bar and 4,5 bar. Lower is the steam pressure, longer is the heating time.

13. COMPRESSED AIR CONNECTION

Connection to compressed air is necessary only for some model: check the technical data sheet. System must be performed by qualified personnel in compliance with national and local rules in force. Each connection between the system and the equipment must be tightness tested; use a leak finder spray, if there is any leak, it needs to be repaired.

14. MASCHINE START AND FINAL TEST

Once the machine is installed, and all connections are made, it must be started following the provided instructions. Each machine part must be tested: start a program and check at least one complete program. The machine must be fully loaded and, in case of high spin machines, the unbalance end switch position must be controlled

15. LANGUAGE CHANGE

When the machine is switched on for the first time, interface language could be different from the one wished by the user. The following procedure explains how to change the interface language. Touch the icon "MENU" of the home page.



The display shows:



Touch the icon "PARAMETERS", the display shows:

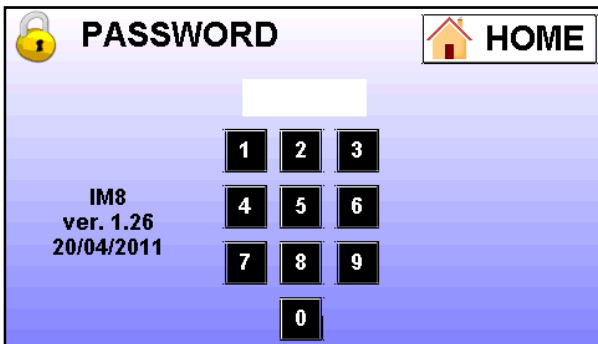

Digit the code "111111" and the display shows:

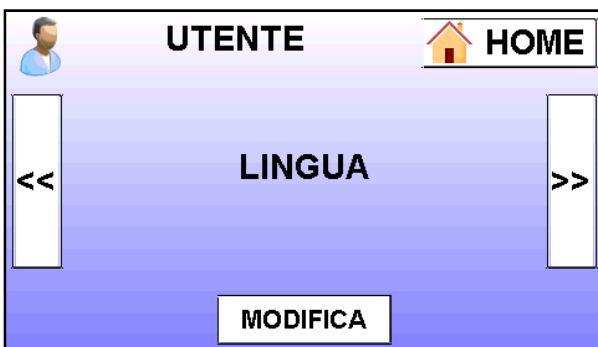

Touch the icon MODIFICA and scroll the menu of the available languages using the keys "<<" and ">>". When the wished language appears on the screen, confirm touching the icon "OK".

Exit the configuration menu touching the icon "HOME" as many time as necessary to reach the home page.

16. REMOTE ASSISTANCE SERVICE ACTIVATION

In case of models equipped with the remote assistance system, the connection to the service server must be activated. In order to do it, check the instructions sent with the machine.

17. WASHING MACHINE USE

Some machine parts must be known before to use the machine for the first time.

The following generic pictures are resuming the possible configuration.

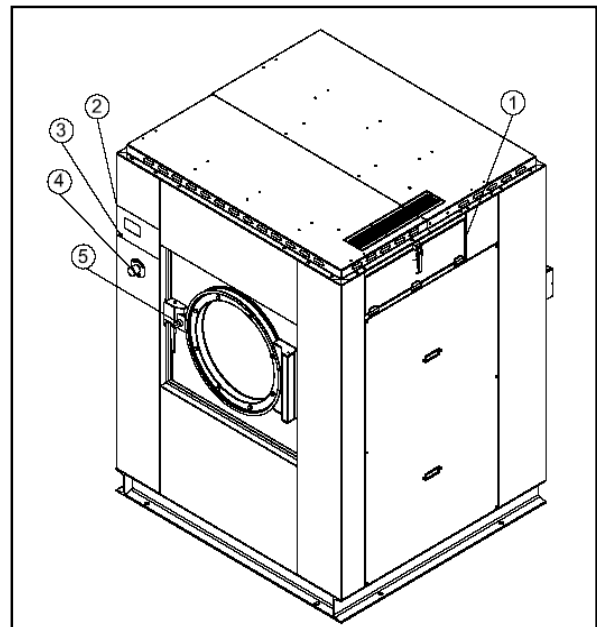
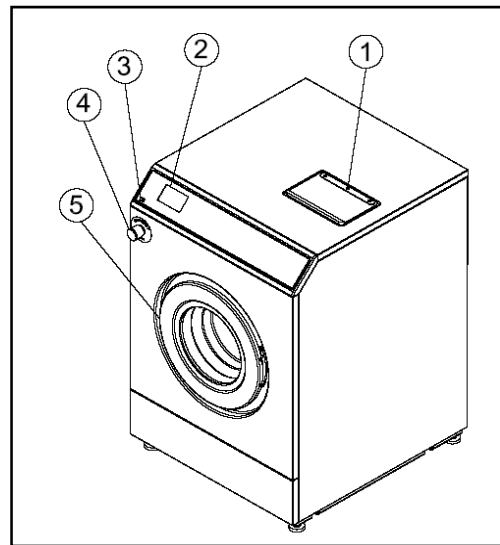

Point 1: detergent box access door.
In the lower capacity machines, the three compartment prewash (P), wash (W), softener (S) are marked by the rubber cover inside.

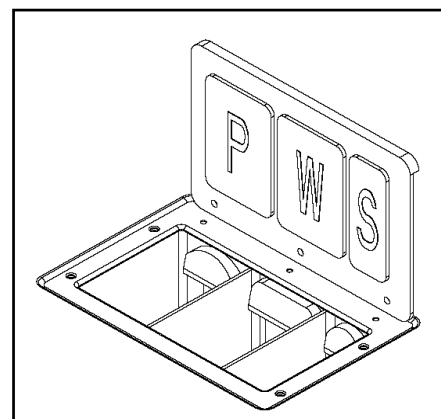

In the higher capacity machines, are available four carafes to load powder or liquid detergents. Detergent loading moments, and opening of detergent corresponding valve, can be programmed.

Point 2: computer display.

Point 3: USB door (A type).

Point 4: emergency stop button.



ATTENTION!

When the emergency stop button is pressed, the electrical supply to machine control is cut. The display switch off and the cycle is automatically interrupted: the turning drum is stopping because of inertia and the tank is emptied.

Emergency stop button must be pressed only in case of danger.

When the emergency situation is finished, the stop button need to be turned right to be armed again. The display switch one and the cycle stand by waiting for the START.

Point 5: machine door hole. In the following paragraphs are described the different kind of locking system which could equipping the different models.

Point 6: main switch.

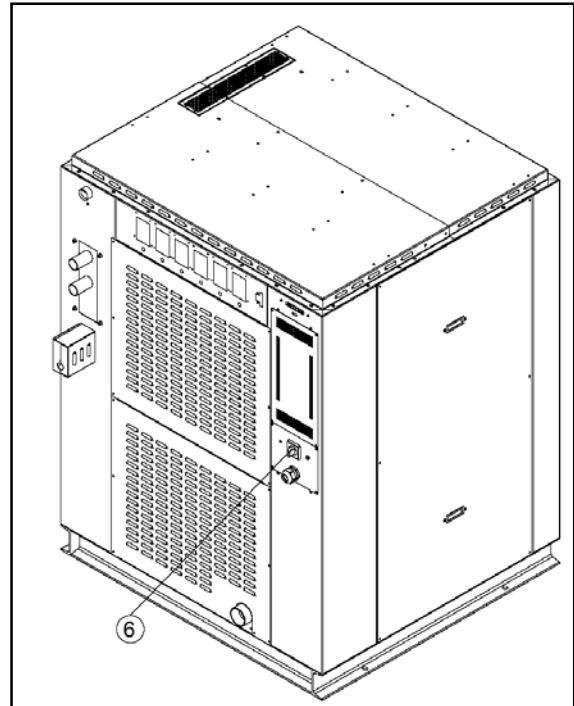
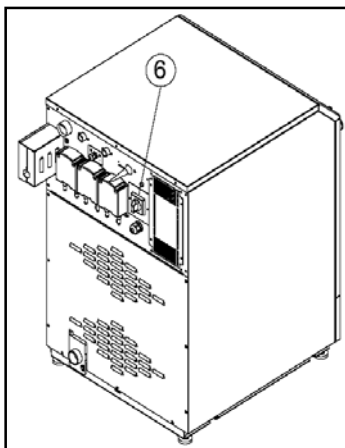

When the main switch is in position "I", the machine is electrically supplied.

When the main switch is in position "0" the machine is not electrically supplied.



ATTENTION!

The air inlet on the machine back, and possibly also on the machine upper panel, must always kept free. Air pass must not be stopped or limited!

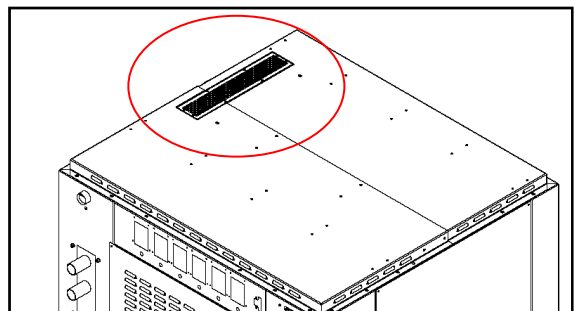





18. LINEN PREPAIRING

Machine must be loaded on the base of the serial number plate: it must not be loaded with a weight higher than the one written in the technical data sheet or in the serial number plate.

Before to chose the most suitable program, the linen need to be sorted into groups homogeneous for fibers and fabrics, in order to have a uniform washing for the whole load.

Before to put the linen into the washing machine, be sure that the linen label is authorizing the machine washing; always stick to linen manufacturer indication.

Here below the meaning of the most common International symbols:

	Maximum temperature: 70°; Mechanical action: midle.
	Maximum temperature: 60°C; Mechanical action: soft
	Maximum temperature: 40°C; Mechanical action: very soft
	Only hand washing
	Not washing

19. HOW TO LOAD THE MACHINE AND CLOSE THE DOOR

The machine must be loaded following the indication given in the serial number plate. The label is stuck on the machine back.



ATTENTION!

Machine must be loaded with linen, which is the most homogeneous possible. The weight of the loaded linen must not be higher than the one indicated in the technical data sheet and in the serial number sticker.

Before to load the linen, be sure that the drum is completely empty. When the machine is loaded, close the door.



ATTENTION!

Be sure that no linen parts are taken between the door and the machine front panel, while the door is going to be closed.

In case of machine without door handle, just press the door against the machine until it is locked.

In case of machine with handle or motorized door lock, the door must just drawn close the machine front, in this way the closing pin enter in the correct position on the machine front.

When the machine is started the computer will give the command to lock the door.

20. DOOR MANUAL OPENING

While the cycle is running it could be possible to open the door manually, without the use of the unlock key on the machine touch screen.



ATTENZIONE!

Before to open manually the door, cut the electricity supply from the main switch.

In case of machine without handle. Open the below front panel. In order to open the door, pull down the string with ring on the left side.

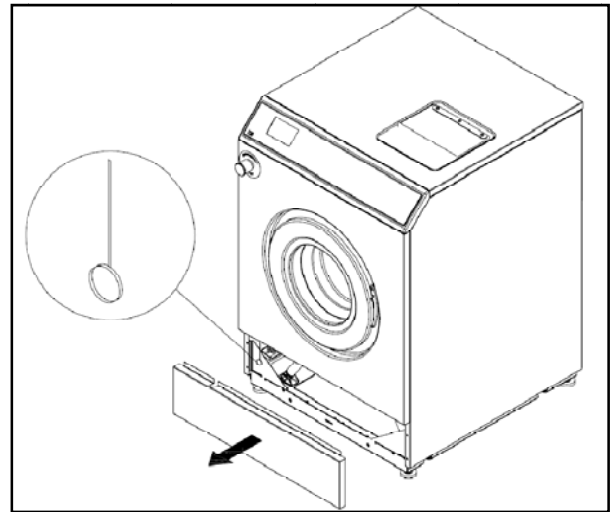

In case of machine with motorized locking: take off the cover (see the picture) and insert a socket box wrench (4mm). Turn right the wrench until the door opens.

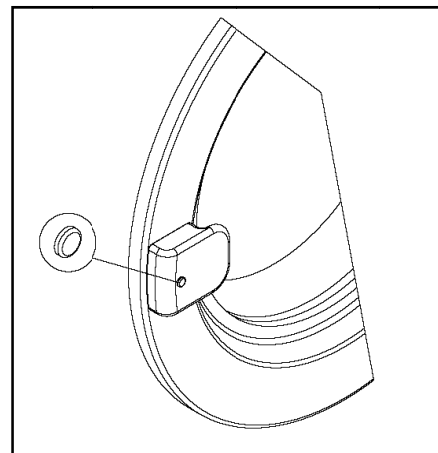

ATTENTION!

Before to supply electricity to the machine, all the protections must be mounted again in the original position!

21. MACHINE SWITCH ON

Turn the machine main switch in position on.

In case of steam heated machine, open the steam gate valve. To limit water hammering cases, the valve must be open slowly passing from the close position to open position in 1 minute time.

The emergency stop button must be in rest position; control that the emergency stop was not activated during the transport or before the machine was switched off last time.

Before to start the machine always check the safety system (refer to the related paragraph).

When the machine is switched on, the software version, as well as its release date, appear on the screen for a while.

The software loading could ask for a minute time, more or less.

The request of machine loading appears on the screen:



Load the machine as requested in the relative paragraph and close the door following the previous given instruction

22. SELECT A PROGRAM

When the machine is loaded and the door is closed, the main MENU screen appears:

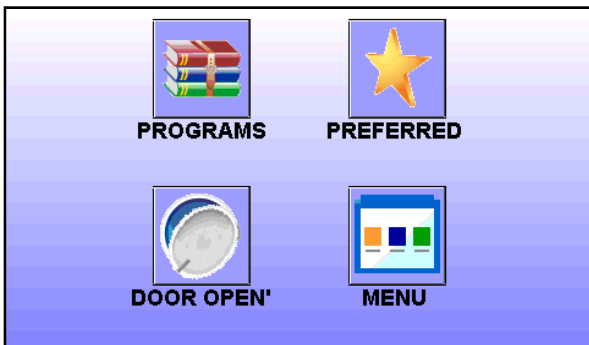

Touching the icon "PROGRAMS" the programs list appears:

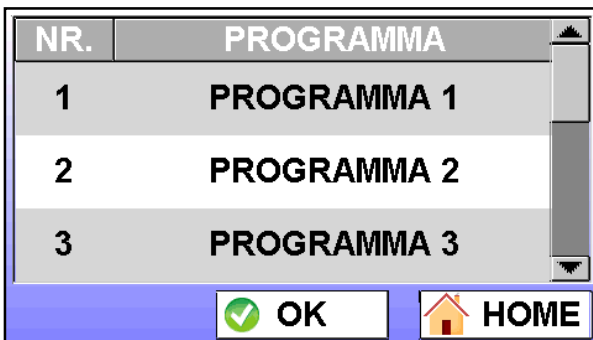

It is possible to scroll down the program list using the bar on the right side. Otherwise, it is possible to go ahead line by line touching the arrows on the right side.

Once the wished program appears on the screen,

touch it, the line background will become blue (example: program 3):

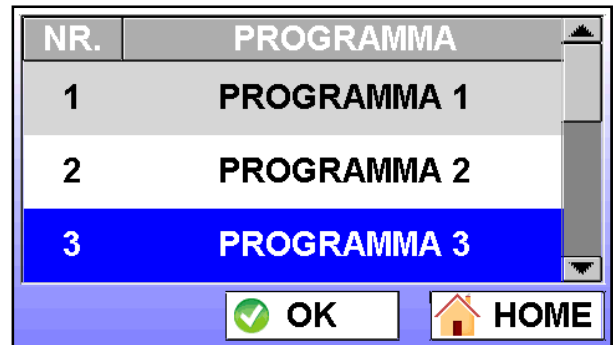

Once "OK" is touched, the selection is confirmed and the following information appears on the screen:

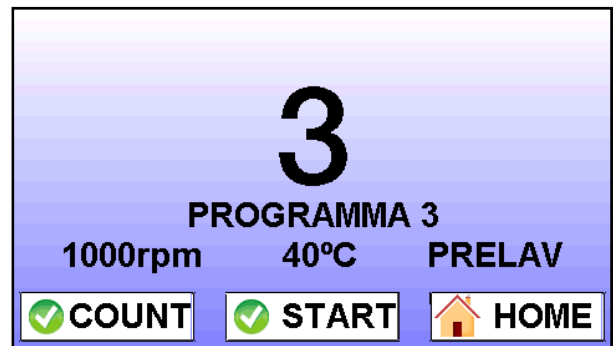

Touch "START".

23. PREFERRED PROGRAM LIST

From the main menu, touching the icon "PREFERRED" it is possible to visualize two program lists:

- the last used program list;
- the list of program set as preferred by the user.

The program selection is done as described in the relative paragraph.

To set a program as preferred, please refer to the on-line manual.

24. DELAYED START

If you want to program a delayed start of a program, select the program as described before, then touch the icon "COUNT"

The screen shows:



It is possible to fix the starting time using the key “+” and “-”.

To exit from this menu touch the icon “BACK”.
When the wished time is visualized on the screen, confirm it touching OK.
The display shows:



Below the indication of delayed start, a countdown is showing how many hours and minutes are missing to the automatic start.

The countdown can be interrupted at any time touching the icon “STOP”.

At the end of the countdown, the cycle will start automatically.

25. PROGRAM EXECUTION

When the program is selected, as described in the previous paragraph, touch “START” to start the program.

The selected program is started.

In case the machine is equipped with motorized locking system, the door is locked, at the program start, this operation ask for some seconds.

While the operation is in execution, the screen shows:

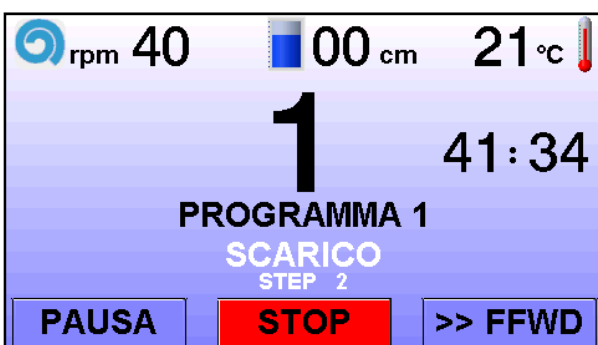

Displayed information enables the user to understand the machine working conditions while the program is running.

All parameters can be changed while the program is running just touching the relative icon.

These modifications stay valid only for the running program. For more information about this function, please refer to online documents.



ATTENTION!

In case of anticipated conclusion of the cycle, remember that the linen temperature may be very high!



ATTENTION!

In case of not correct machine working, switch off the equipment and call the authorized service centre!

26. PROGRAM PAUSE

While the program is running, it is possible to put it in stand by just touching the icon “PAUSE”.

The screen shows:



It is highlighting the soak step and its length.

Soak can be interrupted and the cycle started again touching the icon “START”.

During the soak, the cycle can be interrupted at any moment touching “STOP”.

27. RAPID ADVANCE

To move fast inside the cycle touch the icon “>>FFWD”.

While the machine is in standby, the screen shows:



Here below the symbol meaning:

- “|◀◀” Fast back per cycle
- “◀◀” Slow back per step
- “▶” Start again the cycle
- “▶▶” Slow advance per step
- “▶▶|” Rapid advance per cycle

In the middle of the below bar on the screen, it is written the percentage of program advance.

28. END OF WORKING DAY

At the end of the working day, the machine must be brought at the end of the cycle and switch off, the drum must be cleaned and no linen must be left inside the drum.

Cut any supply to the machine using the suitable switch/knife switch: electricity, steam and compressed air.

Leave the door open.

29. PROGRAM

Program function allows to modified the existing program or to create new programs.

A program is composed by a sequence of steps, which can be modified in anyone of their parameters.

30. PROGRAM MODIFICATION

To modify an existing program, starting from the main menu, touch the icon “MENU”, the screen shows:



Touch the icon “PROGRAM” to enter into the

program area. The screen shows:

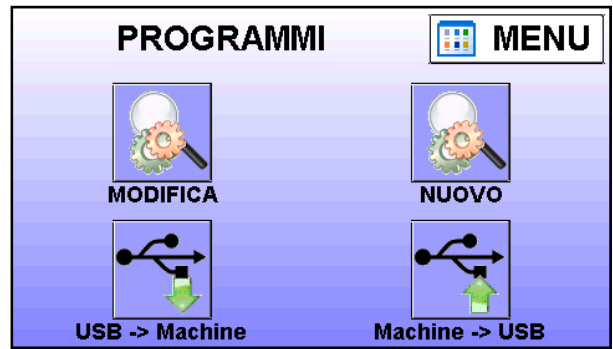

NOTE: the USB communication icons appears only if a USB key is connected and recognized by the system.

To change an existing program touch the icon “MODIFICATION”.

The screen shows the programs list, scroll the list as explained in the paragraph referring to program selection. Select the wished program, the line background will become blue (example: PROGRAM 1).

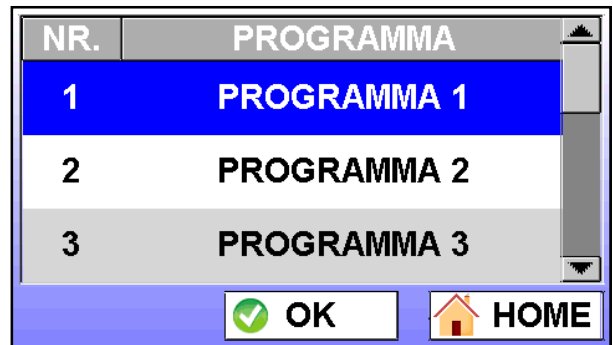

When the wished program is selected, confirm the choice touching the icon OK.

The display shows the sequence of step making the program. The steps are sorted by line. At the same line are described the main characteristics of each step.

n.	step	°C	cm	mm:ss	rpm
1	SCARICO	-	5	-	40
2	SCARICO	-	-	00:10	40
3	CARICO	40	6	-	40
4	DETERGENTI	-	-	00:30	40
5	CARICO	40	13	-	40

To change the characteristics of the step nr 5 (loading), touch the line corresponding to the step. The line background become blue and the a new menu is open:

- STEP BEFORE: it allows to insert a step before the selected one.
- STEP AFTER: it allows to insert a step after the selected one.
- DELETE STEP: delete the selected step.
- CHANGE STEP: it allows to modify the selected step characteristics.
- BLOCK BEFORE: it allows to insert a block of step before the selected step.
- BLOCK AFTER: it allows to insert a block of steps after the selected step.

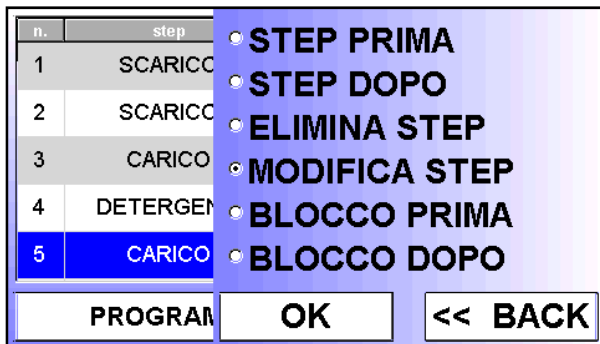

The selected function is marked by point (example: CHANGE STEP).

Programmable step are:

- DRAIN
- LOAD
- COOLING
- HEATING
- PREWASH
- WASH
- RINSE
- DETERGENT
- DISTRIBUTION
- SPIN
- GENERIC

The single step characteristics appears only if they can be modified.

In the example the CHANGE STEP option is selected.

To exit from the modification menu, touch "BACK"
To proceed touch the icon "OK". In the previous example the step n. 5 (LOADING) was selected.

The steps parameters can be visualized touching the available labels (MOTOR, LEVEL, TEMPERATURE).

The following pictures shows the screens which can appear.

If the "MOTOR" label is selected, the following screen appears. Here it is possible to select the motor kind (turning rhythm and pause) and the rotation speed expressed in RPM.

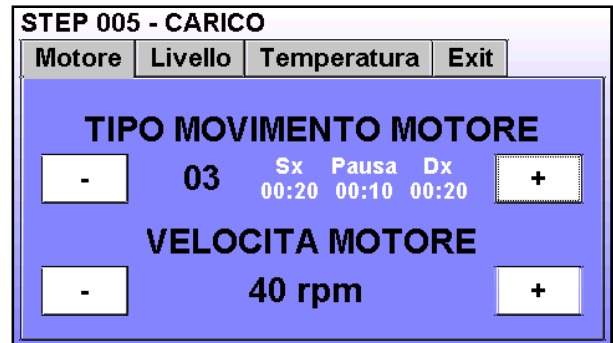

If the "LEVEL" label is selected, the following screen appears. Here it is possible to select the water level expressed in centimeters and the loading safety time (WDT).

NOTE: if the water level is "0", the "LOADING TIME" lose its meaning of Watch Dog Timer and assume the value of valve activation time.



At the same screen it is possible to choose the kind of electrovalve to active during the loading step: COLD, HOT or the BALANCE LOADING. In the last case, the step starts loading 1cm cold water and the hot and cold water one after the other until the fixed level is reached.

When the selected label is "TEMPERATURE", the following screen appears. Here it is possible to fix the water temperature using the icons "+" e "-".

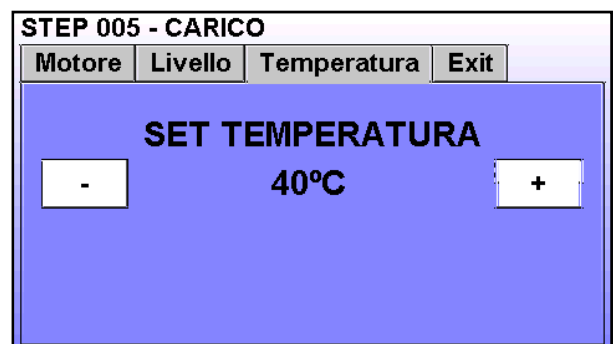

When the modification are completed, touch the icons "EXIT". The display shows:



Here it is possible to confirm or not the modifications.

All the above described functions are available also in case of:

- Insert a STEP BEFORE
- Insert a STEP AFTER



On the screen appears the sequence of available steps: it is possible to scroll the sequences using the key “-“ e “+”.

Select the step and confirm your selection with “OK” or touch “HOME” to exit from this menu.

Steps added (before or after the blue selected steps) have default value which can be modified following the previous given instructions.

It is also possible to insert some blocks (before or after the selected step).

A BLOCK is a prearranged sequence of step, it means that it is a complete cycle.

All the functions described in case of the single step, are available also in case of the selection:

- Insert a “BLOCK BEFORE”
- Insert a “BLOCK AFTER”



Once a block is selected, the parameters of the step forming this block could be modified at will.

31. EASY PROG

It is a simplified procedure for the construction of a new program.

To enter in this function select “MENU” among the home selections.

On the screen appears:



Select the function EASY PROG touching the corresponding icon.

On the screen appears:



After this message, the questions about the new program configuration will appear on the screen one after the other.

At each question, answer selection one answer among the ones on the list and confirm touching “OK”.

The selected answer correspond to the one with the “focused” icon, the “blurred” icons correspond to the not selected icons.

The program questions sequence can be interrupted at any time touching “HOME”.

It also possible to go back to previous program step touching the icon "BACK".

The first question ask for the necessity or not of a prewash cycle.



Select the wished icon (example: Prewash, yes) and confirm with "OK".

Now appears the second question, referring to the washing cycle temperature.

Set point temperature is written at the center (example: 40°), use icons on the side to increase or decrease the temperature.

Confirm the value touching "OK".

When the washed temperature is set, prewash temperature is also set (if prewash was requested in the previous step). Temperature of prewash is set at the half of the washing temperature (Example: 20°C).

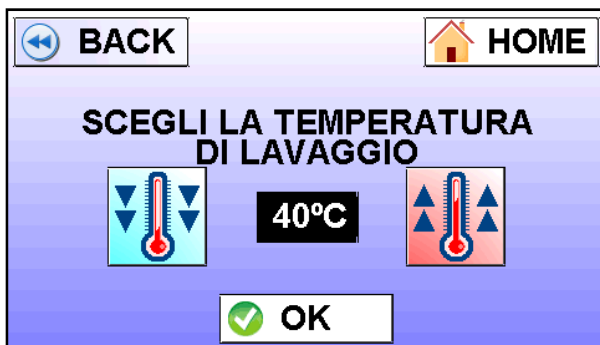

When the chosen temperature is confirmed, it is asked to select the kind of washing mechanical action (in our example: MEDIUM).

The selected mechanical action impacts on prewash, wash and rinse cycles, because it determines the drum speed.



Confirm the selection touching "OK".

The following question refer to the end spin speed. Using the icons "▼" and "▲" it is possible to increase or decrease the end spin speed.

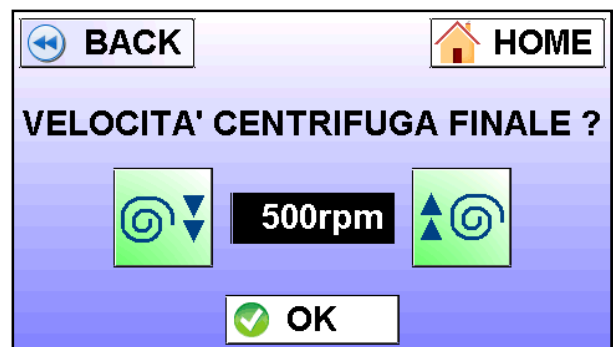

Once the wished value is reached, confirm it touching "OK".

When the end spin speed is confirmed (example: 500 rpm), also the middle spin speeds are set. The middle spin speed is half of the end spin speed.

The next question refer to the number of rinses:

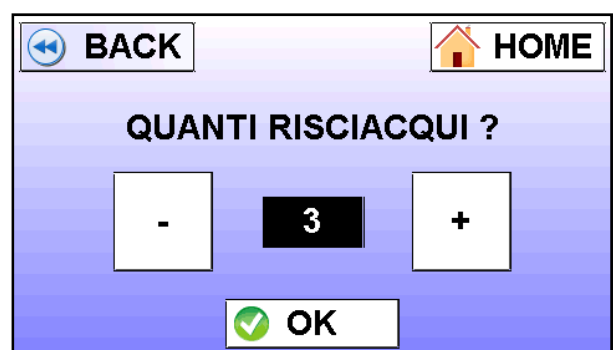

Change the rinse number using the icon "+" and "-". Setting the number of rinse, is set also the total number of spin.

To confirm the number of rinses (example: 3) touch "OK".

The last question refer to the drum load:



In this step is possible to configure a program for half load or full load (example: full load). Setting the drum load, it is set also the detergent and water level. Once the drum load is selected confirm touching the icon "OK".

The screen shows:

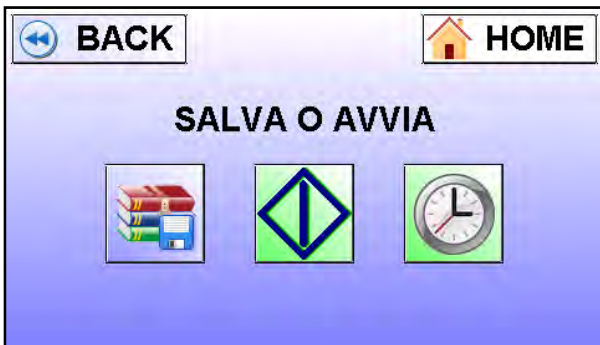

The program procedure with EASY WASH is now completed. The program can be start immediately touching "START", in this case the program will not be saved.

A program delayed start can also be selected touching the "CLOCK" icon (see the procedure in the relative paragraph). In this case the program will start at the fixed time, but it will not be saved.

To save the program touch the icon "SAVE" and follow the saving procedure.

For updates on the function and for more information, please see the online documentation.

32. SELF DIAGNOSTICS

The computer supply a complete diagnostics both in case of not correct working and in case of simple reports.

The following table refer to a list of messages which could appear on the screen.

It is suggested to contact the authorized service center in case one of the following messages would appear.

COD	DESCRIPTION	WHAT IS HAPPEN, WHAT TO DO
1	MOTOR OVERHEATING	The display shows: "ALARM !!! 01 Motor overheating". The machine stops, a buzzer is activated for 15 seconds. When the screen is touched, the alarm is reset and the door opens. A motor overheating occurred: wait until the motor cool down and start again the cycle. If the alarm appears often, please contact the authorized service center.
2	DOOR OPEN	The display shows: "ALARM !!! 02 Door open". The machine stops, a buzzer is activated for 15 seconds. When the screen is touched, the alarm is reset and the door opens. The door opens while the washing program was running, please contact the authorized service center.
3	TEMPERATURE PROBE	The display shows: "ALARM !!! 03 Temperature probe" (following the kind of temperature probe, the displayed temperature passed from 237°C to 0°C). The machine do not stop, but all the heating step are skipped. When the screen is touched, the alarm is reset. Temperature probe is damaged, contact the authorized service center.

COD	DESCRIPTION	WHAT IS HAPPEN, WHAT TO DO
4	LOAD WDT	<p>The display shows: "ALARM !!! 04 Load timeout". The machine stops, a buzzer is activated for 15 seconds. When the screen is touched, the alarm is reset and the door opens. The maximum time fixed for water loading is expired. Control if the water taps are opened, the filters are clean and there are no water leakage. If the alarm appears often, please contact the Authorized Service Center.</p>
5	DRAIN WDT	<p>The display shows: "ALLARM !!! 05 drain timeout". The machine stops, a buzzer is activated for 15 seconds. When the screen is touched, the alarm is reset and the door opens. The maximum time to drain the water is expired. Check if the drain system is clean. If the alarm appears often, please contact the Authorized Service Center.</p>
6	COIN BLOCKED	<p>If a payment input is longer than 6 second, the display shows: "ALLARME !!! 06 Coin blocked". The alarm stays until the payment system is unblocked. When the payment system works again correctly, the main screen appear.</p>
7	UNBALANCE	<p>During the spin cycle, the drum was gone out of balance. A balancing cycle starts and the machine attempt again the spin.</p>
8	TRIPLE UNBALANCE	<p>During the same spin, more unbalance occurs: the spin cycle is left and the program pass to the next cycle. If the problem occurs often, be sure that the drum is correctly load (nominal capacity, homogeneity of the load).</p>
9	INVERTER LOCK	<p>The display shows: "ALARM !!! 09 Inverter Lock". A inverter lock occurred. The cycle is not interrupted, but the drum does not turn. The alarm is reset when the screen is touched. NOTE: the message could contain the inverter alarm code. Please contact the Authorized Service Center</p>
11	HEATING WDT	<p>The display shows: "ALARM !!! 03 heating timeout". The maximum time to heat the water is expired. The cycle does not stop, but the heating steps are skipped. When the screen is touched, the alarm is reset. Please contact the Authorized Service Center.</p>
13	OVERHEATING	<p>The display shows: "ALARM !!! 13 Overheating". The water temperature is above 110°C. The heating system is deactivate and the next heating steps are skipped. Please contact the Authorized Service Center.</p>
14	MAINTENANCE	<p>The display shows "Maintenance request". It is achieved the number of cycles necessary for the maintenance request. Please contact the Authorized Service Center.</p>

COD	DESCRIPTION	WHAT IS HAPPEN, WHAT TO DO
15	ZERO MOTOR WDT	The display shows "WDT Zero Motor". The maximum time for the door opening is expired, please contact the Authorized Service Center.
16	DOOR CLOSING WDT	The display shows "WDT Door closing". The maximum time for the door closing is expired, please contact the Authorized Service Center.
17	DOOR OPENING WDT	The display shows "WDT Door opening". The maximum time for the door closing is expired, please contact the Authorized Service Center.
21	TANK 1 ...8 FINISHED	The display shows "TANK 1 FINISHED". One of the detergent tank (from 1 to 8) is finished. Replace or fill the relative tank.
-	POWER FAILURE	The display shows "POWER FAILURE". While a program was running, the electrical supply was interrupted. When the electrical supply come back, the machine wait for 40" while the alarm "POWER FAILURE" is flashing on the screen. Touching "START" the program resumes from the interruption point.

33. PROGRAM SET BY THE FACTORY

The machine is delivered with 8 program already set by the factory. These programs can be changed by the user as explain in the relative paragraph.

Program description:

PROGRAM 1
Prewash 40°C
Wash 90°C
Rinse : 3
Spin: 4
Max spin speed: 1000 RPM

PROGRAM 2
Prewash 30°C
Wash 60°C
Rinses: 3
Spins: 4
Max spin speed: 1000 RPM

PROGRAM 3
Prewash 35°C
Wash 40°C
Rinses: 3
Spins: 4
Max spin speed: 1000 RPM

PROGRAM 4
Prewash cold

Wash 30°C
Rinses: 3
Spins: 3
Max spin speed: 1000 RPM

PROGRAM 5 "WOOL"
Prewash cold
Wash 30°C
Rinses: 3
Spins: 1
Max spin speed: 450 RPM

PROGRAM 6 "COLD"
Prewash cold
Wash cold
Rinses: 3
Spins: 4
Max spin speed: 1000 RPM

PROGRAM 7 "HOSPITAL"
Prewash 40°C
Wash 90°C
Rinses: 5
Spins: 6
Max spin speed: 1000 RPM

PROGRAM 8 "VERY DIRTY WOOL "
Prewash cold
Wash 30°C

Rinses: 5
 Spins: 2
 Max spin speed: 450 RPM

NOTE: in case of low spin washing machines, the maximum spin speed is 450 rpm. The spin speed is merely indicative and can change according to the machine capacity (check the G factor effective value on machine technical sheet).

34. OTHER FUNCTION

There are a lot of other functions which are available and which are updated very often. Enter the manufacturer’s website restricted area to download the software updating files and to control the new implemented functions.

The following instructions are not described in this manual, but are available on the web site:

- Configuration of the coin op machine;
- WIZARD to program the machine;
- Pictures personalization;
- Drum movement;
- Program up- and download;
- Software and firmware updating;
- USB connection;
- SD unity;
- Remote assistance service;
- Parameter change while a program is running.

35. WASHING MACHINE MAINTENANCE

Each service must be performer only by qualified personnel.

Cut any supply to the machine before to proceed with any service.

Here below the ordinary and extraordinary maintenance operation are listed.

EACH DAY

- The machine must be kept clean using neutral detergent. Clean the machine external panel in order to eliminate any detergent stain, also from the detergent box.
- Door gaskets need to be cleaned.
- Air inlet and exhaust need to be cleaned.
- The drum cleanness condition need to be checked: be sure there are no deposits.
- At the end of the working day, the door must be left open to air the inside.
- At the end of the day cut any supply (energy or water) to the machine.

EACH THREE MONTHS

- Check the efficiency of the drum belts and the drum clearing: be sure that there are no deposit on the drum surface.
- Check the drain valve cleaning.
- Check the inlet valve, and the corresponding filter, cleaning.

EACH YEAR

The authorized service center must be contacted to:

- Clean the machine inside;
- Check the wiring contacts efficiency;
- Ceck the teightness and the integrity of the rubber parts;
- Grease the mechanical parts, the one which ask for this treatment.
- Clean the motor air inlet.



ATTENTION!

In case of tilting machines, before to start any maintenance, be sure that the air circuit is completely release and that the pneumatic action mechanism cannot move, even in case of no electricity supply.

In case of maintenance in no-rest position of some parts, be sure that the pneumatic action mechanisms are mechanically locked.

36. WASHING DEFECTS

In case the washing results is not satisfactory, please check the following table.

PROBLEM	Possible SOLUTION
Garments are still wet	Check if the program ends with a spin. It is possible that some unbalance error occurred, load correctly the linen and start a spin.
Garments have visible marks from the drum	Check the spin speed, maybe it is too high.
Garments are felted	Check spin speed and the temperature of the used cycle. Check the linen washing instructions, as well as the program characteristics and if the washing machine use is allowed.

37. TILTING MACHINE USE

In case the machine is equipped with the tilting system, the following instructions must be also observed.

In this case programs are managed by a remote a control.



ATTENTION!

When the machine is tilting, or the pneumatic door is opening, the user must not stay closed to the machine. To control the machine use the suitable remote control.

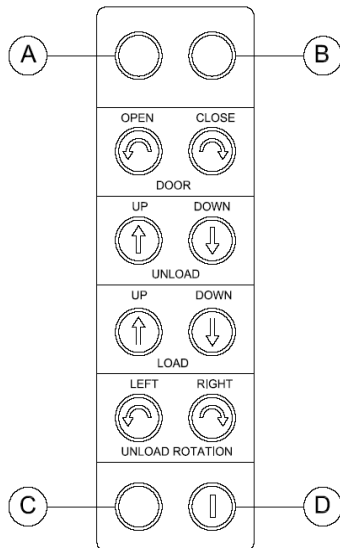

Always wait for the program end before to action the tilting function. The remote control use is switched on or off using the key switch (D). When the remote control is activated, the microprocessor of the machine is deactivated. The activation of the remote control is signaled by the green light (A).

LOADING OPERATION (only 2 way tilting machines)

Switch on the remote control. Press the enabling key (below left) and the "DOOR OPEN" key at the same time to open the door. When the door is completely opened, tilt backward the machine pressing at the same time the enabling key (C) and the key "LOAD UP". When the machine loading is finished, bring again the machine to the horizontal position pressing at the same time the enabling key (C) and the key "LOAD DOWN". Close the door pressing at the same time the enabling key (C) and the key "CLOSE DOOR". Switch off the remote control using the key (D).

UNLOADING OPERATION

Switch on the remote control using the key (D). Press the enabling key (below left) and the "DOOR OPEN" key at the same time to open the door. When the door opening is completed, tilt the machine forward pressing at the same time the enabling key (C) and the "UNLOAD DOWN". When the machine is the unloading position, press at the same time the enabling key (C) and

the key "UNLOAD ROTATION" (RIGHT and/or LEFT). When the unload completed, bring again the machine in horizontal position pressing at the same time the enabling key (C) and the key "UNLOAD UP".

Close the door pressing at the same time the enabling key (C) and the key "CLOSE DOOR". Switch off the remote control using the key (D).

38. SAFETY DEVICES CONTROL

Switch on the machine; before to start the program, always control the perfect safety devices work.

The user must always follow the procedure in the below table:

ACTION	REACTION
Start a cycle and press STOP...	... the machine must stop and wait for a new start.
Press the emergency stop button the drum must stop and the machine must switch off.



ATTENTION!

When the machine is switch on, before to start any program, alias control the perfect safety devices work.

39. SCRAPPING

When the machine life cycle arrives to the end, please proceed with the machine scrapping following the country rules, keeping separate the metallic, the plastic, the glass, the electric/electronic parts.



The above symbol on the appliance or on the package means that at the end of its life cycle this product must be collected separately from other waste material.

For this appliance waste separation, follow the rules in force in the Country where the machine is installed.

A correct waste separation avoid dangerous impact on the environment and make easier the material recycling.

Unlawful disposal may caused application of administrative sanction, following the rules in force in the country where the dryer is installed.

**ATTENTION!**

In case the machine should not be more used before the dryer disposal, make the door lock out of service, to avoid that somebody close himself inside risking his life.

40. WARRANTY CONDITIONS

For the warranty condition, check the manufacturer price list.

**ATTENTION!**

To benefit of the manufacturer warranty condition, the manual instructions must be carefully followed. In particular:

- Work always respecting the dryer use limits;
- Maintenance must be always correctly operated;
- The dryer must be used only by well trained personnel;
- Use only original spare parts.