

MOD : HP50M-1M

Production code : STM006G001-DI



INDICATIVE PRODUCT IMAGE

Product file

Type	split
Mounting	Horizontal
Code	STM006G001-DI
Range	ST
Condensation	Air
Net weight	56.5 kg
PED	0
Defrost	Electrical
Expansion	Capillary
Application	MBP
Refrigerant	R452A

Dimensions

Width L	700 mm
Depth P	490 mm
Height H	380 mm

Pipe fittings

Liquid diam.	6 mm
Suction diam.	10 mm

Absorptions

Power consumption	810 W
Current consumption	5 A
Potenza sbrinamento	650 W

Condenser

Fan-motors no.	2
Diameter	254 mm
Air flow	1211 m ³ /h

Unit cooler

Fan-motors no.	1
Diameter	200 mm
Air flow	600 m ³ /h
Air throw	3 m

Compressor

Type	Hermetic
Compressors no.	1
Brand	EMBRACO
Voltage	220-240/1/50
Displacement	12.12 cm ³

Technical data - HP50M-1M

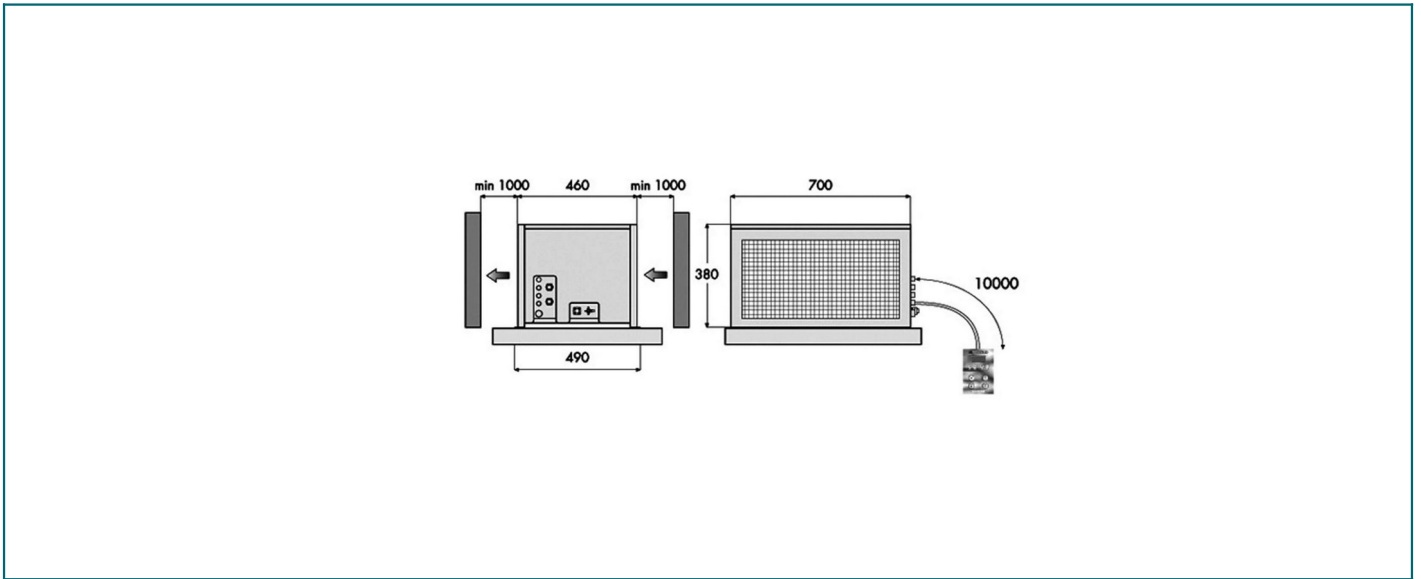

Technical data - HP50M-1M

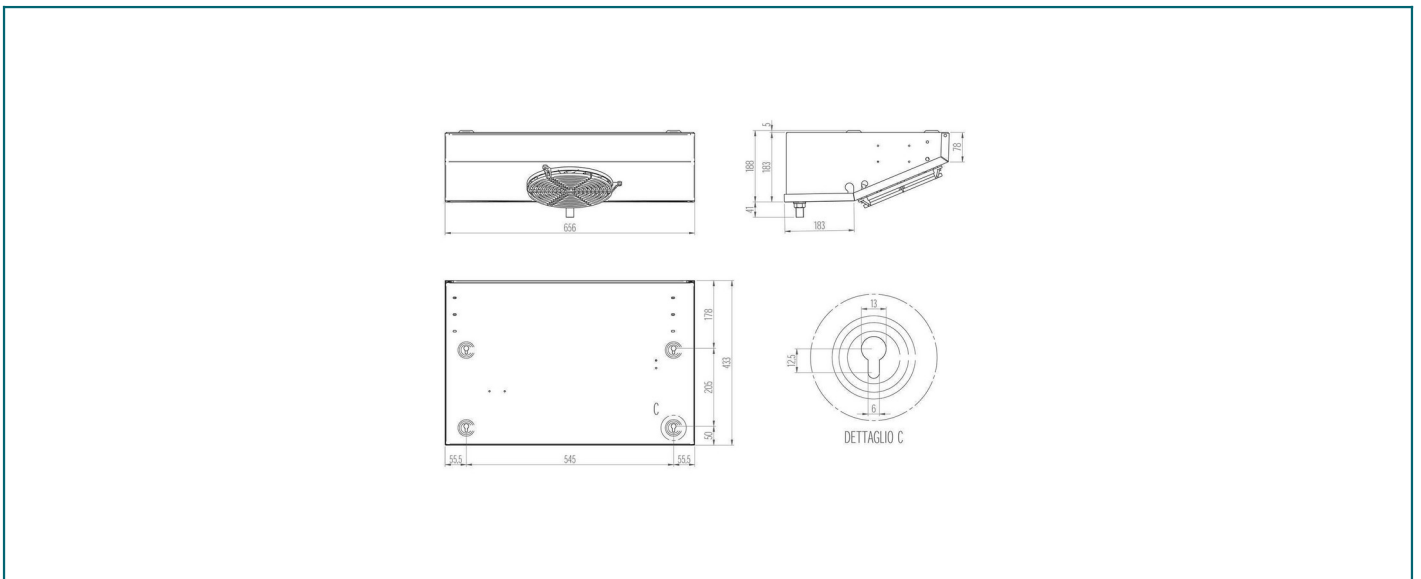

Refrigerating capacity table (W) - HP50M-1M - Refrigerant: R452A

TA \ Cold room Temp	-5 °C	0 °C	5 °C
25 °C	1020 (6.7 m³)	1162 (8.1 m³)	1325 (12.6 m³)
32 °C	922 (5.8 m³)	1060 (7.1 m³)	1212 (11.1 m³)
43 °C	774 (4 m³)	899 (5.3 m³)	1031 (8.3 m³)

Values referred to :

Suction gas : +20°C

Subcooling : 0K

Superheat : 100%

Compressor absorption :

Te -5°C (HBP); Tcond +50°C

Te -10°C (MBP); Tcond +50°C

Te -30°C (LBP); Tcond +50°C



INDICATIVE PRODUCT IMAGE

General features

- Self-supporting casing in zinc-plated metal sheet, which is coated with epoxy powder and easily removable panels for fast access to components during inspection or maintenance operations
- Hermetic or semi-hermetic compressors with motor thermic protection
- Electronic control board that can be programmed according to different user requirements
- Control panel installed in a remote position
- Heat exchangers with copper and aluminium blocks
- Condensation by air (optional by water)
- Expansion by capillary tube or thermostatic valve
- Ventilation or heater automatic defrosting with programmable run duration and frequency
- Condensing water direct discharge
- Electronic card designed for connection in remote management (BMS) and LAN.

For Model up to 2x450

- Low pressure switch
- Remote control panel (10m)
- Door micro switch with 10m long cable
- Cold room light with 10m long cable
- Door heater cable for LBP items with 10m long cable
- Connecting cables evaporator/condensing unit L= 10m
- Power supply cable (L=2,5m)

For models 2x560 2x630

- Remote control panel 20m
- High-low pressure switch
- Pressure switches for condenser fan control
- Crankcase heater
- Package included