

10/2016

# Mod: TSU32/BT-N

Production code: 21327022F



**Diamond**  
catering equipment



- AISI 304 stainless steel construction
  - Powerful IP 55 insulated and fan-cooled motors for continuous use
  - Endless screw motor-reducer running in an oil-bath enables a long service life
  - Motor-reducer equipped with a double seal for long, trouble-free service
  - Convenient head interlock mechanism (CE versions)
  - Stainless steel mincing head carefully designed for high yield production
  - Feed tray designed with square neck for outstanding performance
  - Feed tray provided with safety interlock (CE versions)
  - Stainless steel IP 67 protected controls with reverse.
- Options:
- Interlock protection for more than 8 mm holes plates. (An interlock protection system is required in order to utilize more than 8 mm holes plates)
  - Partial or total Unger system mincing head
  - Plexiglass feed tray lid
  - Patty-forming attachment FORMAT M.

Data sheet

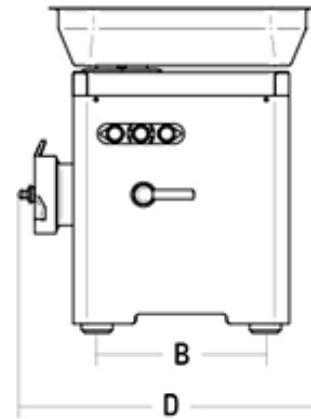
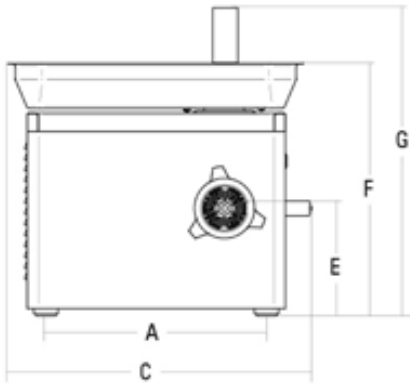

Model	TC 32 NEVADA
<b>Power:</b>	1ph watt 1.840/Hp 2,5 - 3ph watt 2.200/Hp3
<b>Power source:</b>	230-400V50Hz
<b>Output/h.:</b>	kg/h. 650
<b>Standard plate:</b>	ø mm 4,5
<b>A:</b>	mm 480
<b>B:</b>	mm 285
<b>C:</b>	mm 637
<b>D:</b>	mm 455
<b>E:</b>	mm 207
<b>F:</b>	mm 447
<b>G:</b>	mm 551
<b>Net weight:</b>	kg 50
<b>Shipping:</b>	mm 720x570x770
<b>Gross weight:</b>	kg 72
<b>HS-CODE:</b>	84385000