

10/2016

Mod: TTGD-42/DC-N

Production code: 2142201323213



Diamond
catering equipment



- AISI 304 stainless steel construction.
- Can be sprayed.
- 5 Hp and 7 Hp three-phase motors.
- Oil-bath, water protected gear box.
- Grinding set:
 - Completely made from AISI 304 stainless steel.
 - Designed for high performance
 - Machine works perfectly even if product is processed two or more times
 - Hourly output: 1.100 Kg (actual) (42)
 - Hourly output: 3500 kg (possible)
 - Unprocessed meat inside grinding set at working cycle end: 50-90 g.
 - Stainless steel drive pin.
 - Exclusive, patented plate and ring nut detection system (CE)
 - Tempered steel worm pin.
 - Grinding set is quickly disassembled of faster cleaning and sanitation.
 - Square feeding "neck" allows for faster processing cycles.
 - Large 563x 900 x h 120 mm feeding hopper with safety microswitch
 - IP 67 water protected stainless steel controls with reverse (on CE versions).
- Standard accessories:
 - Stainless steel self-sharpening knife and 4,5 mm plate
 - Product pusher
 - Worm and plate removing tool
 - Use and maintenance manual
- Optional:
 - FULL CONTROLS for accessories handling
 - Stainless steel splash guard
 - Pedal control
 - Stainless steel 1/2 unger grinding set
 - Stainless steel total unger grinding set
 - Longer head
 - Interlock protection for more than 8 mm holes plates. (An interlock protection system is required in order to utilize more than 8 mm holes plates).
 - Wide selection of plates and knives
 - FORMAT S
 - FORMAT A

Data sheet

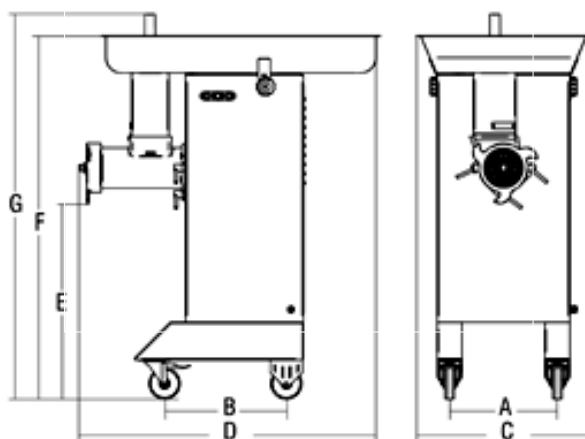

Model	TC 42 Montana Hp 5	TC 42 Montana Hp 7	TC 42 Montana Tramoggia Gigante	TC 42 Montana Bocca Lunga	TC 42 Montana TG+BL
Power:	watt 3675 - Hp 5	watt 5145 - Hp 7			
Power source:	230-400V/50Hz	230-400V/50Hz			
TC Output/h.:	kg/h. 800-1000	kg/h. 1200-1300			
Standard plate:	ø mm 4,5	ø mm 4,5			
A:	mm 348	mm 348	mm 348	mm 348	mm 348
B:	mm 393	mm 393	mm 393	mm 393	mm 393
C:	mm 564	mm 564	mm 626	mm 564	mm 626
D:	mm 973	mm 973	mm 1125	mm 1063	mm 1215
E:	mm 631	mm 631	mm 631	mm 631	mm 631
F:	mm 1171	mm 1171	mm 1282	mm 1171	mm 1282
G:	mm 1241	mm 1241	mm 1282	mm 1241	mm 1282
Net weight:	kg 112	kg 112	kg 128	kg 132	kg 148
Shipping:	mm 1050x950x1960	mm 1050x950x1960	mm 1050x950x1960	mm 1050x950x1960	mm 1050x950x1960
Gross weight:	kg 137	kg 137	kg 153	kg 157	kg 173
HS-CODE:	84385000				