

11/2013

Mod: ES10/A4

Production code: ES094B



Diamond
catering equipment

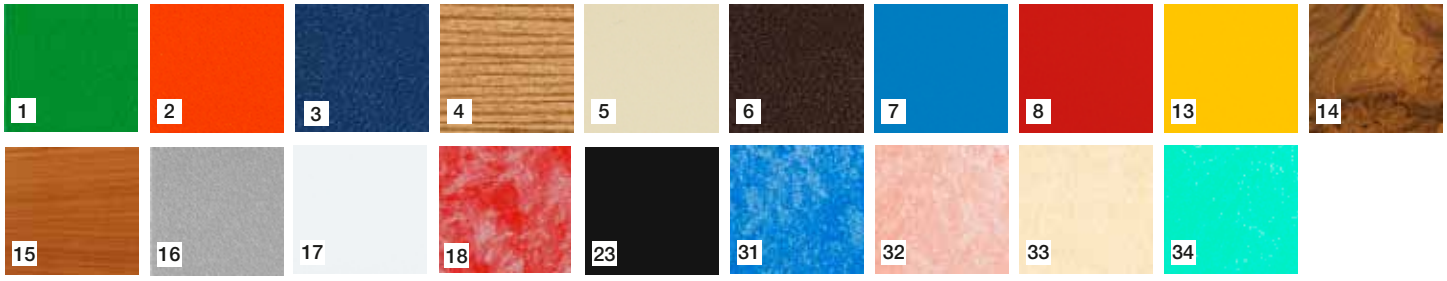
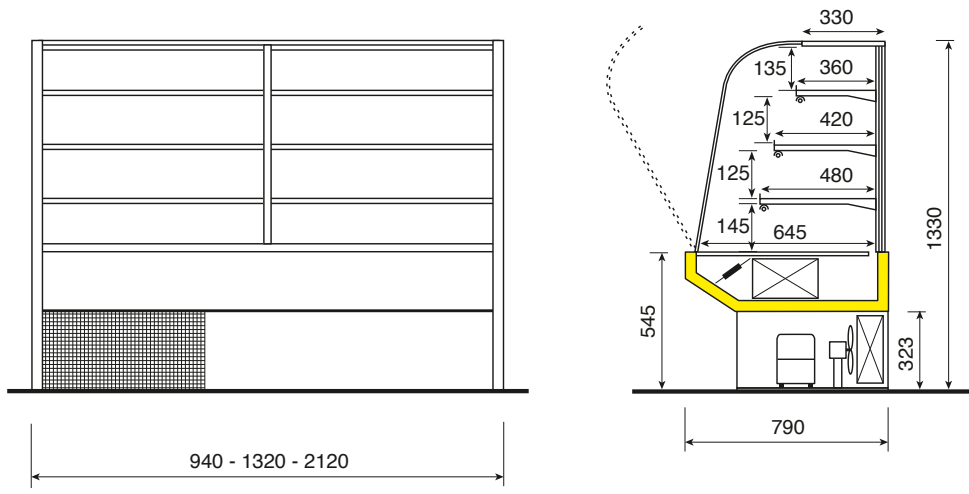

Lunghezza con spalle Length including ends Longueur avec joues Moebellaenge mit Seitenteilen	Temperatura di esercizio Working temperature Temp. de fonctionnement Betriebstemperatur	Tensione di alimentazione Supply voltage Tension d'alimentation Speisespannung	Watt assorbiti Watt absorbed Watt absorbés Nennleistungsaufnahme Watt	Potenza frigorifera Refrigeration power Puissance frigorifique Kälteleistung Watt (-10°C)	Evaporazione elettrica* Electric evaporation* Evaporation électrique* Elektrische Verdunstung* Watt	Illuminazione Lighting power Eclairage Beleuchtung Watt	Superficie espositiva Display surface Surface d'exposition Auslagefläche m2
940	25° C u.r. 60% +7°/+10° C	230V/50 Hz	762	1054	400	4x18	1,45
1320			779	1153	400	4x30	2,10
2120			1091	1936	400	4x58	3,46

* Consumo della resistenza della vaschetta elettrica
 * Consumption of the heater of the electric evaporation pan
 * Consommation de la résistance du bac d'évaporation électrique
 * Verbrauch der Heizung der elektrischen Tauwasserschale

I dati delle unità refrigeranti si riferiscono alla versione gruppo incorporato 230V/1/50Hz R404a
 The details of the refrigerating units are referred to cabinets with built-in unit in 230V/1/50Hz R404a
 Les données des groupes réfrigérants sont pour vitrines avec groupe logé 230V/1/50Hz R404a
 Die technischen Daten der Kühlmaschinen beziehen sich auf Vitrinen mit eingebautem Aggregat 230V/1/50Hz R404a