

07/2013

Mod: 300/BS

Production code: 153035B02WHL

Professional slicer

OPERATING AND MAINTENANCE MANUAL

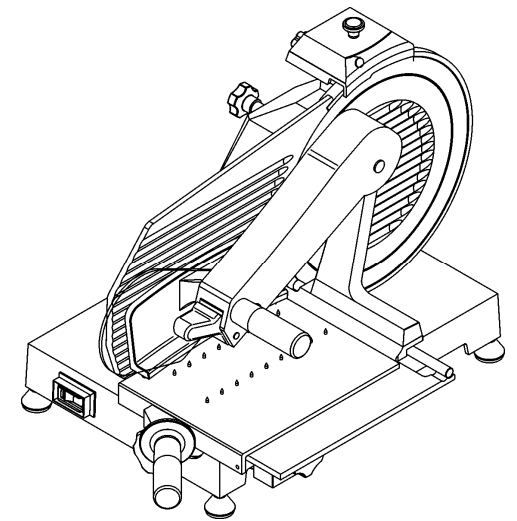
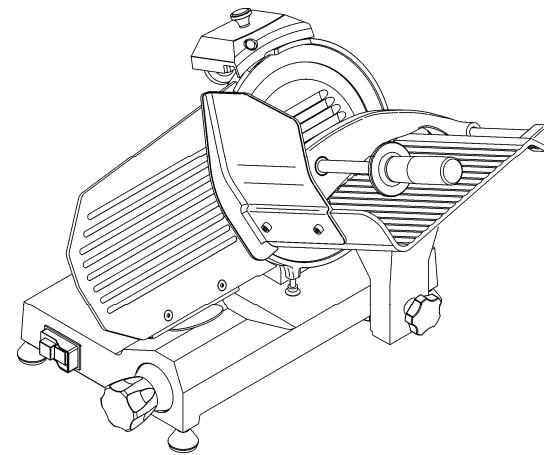

**SERVICE CENTRE
AUTHORISED DEALER**

Ed. 05/2011

INTRODUCTION

- This manual is meant to provide customers with information on the slicer and its specifications and the necessary operating and maintenance instructions in order to guarantee the best possible use of the machine and preserve its efficiency in the long term.
- This manual is to be used by qualified and skilled people well informed about the use of the slicer and its periodical maintenance.

TABLE OF CONTENTS

CHAP. 1 - INFORMATION ON THE SLICER	pag. 4
1.1 - GENERAL PRECAUTIONS	
1.2 - SAFETY SYSTEMS INSTALLED IN THE SLICER	
1.2.1 - mechanical safety system	
1.2.2 - electrical safety system	
1.3 - SPECIFICATIONS OF THE SLICER	
1.3.1 - general description	
1.3.2 - construction features	
1.3.3 - slicer components	
CHAP. 2 - TECHNICAL DATA	pag. 8
2.1 - OVERALL DIMENSIONS, WEIGHT, CHARACTERISTICS	
CHAP. 3 - SUPPLY OF THE SLICER	pag. 12
3.1 - DISPATCH OF THE SLICER	
3.2 - PACKAGE CHECK UPON ARRIVAL	
3.3 - PACKAGING DISPOSAL	
CHAP. 4 - INSTALLATION	pag. 13
4.1 - SETTING UP OF THE SLICER	
4.2 - ELECTRIC CONNECTION	
4.2.1 - slicer equipped with a single-phase motor	
4.2.2 - slicer equipped with a three-phase motor	
4.3 - ELECTRIC CIRCUIT DIAGRAM	
4.3.1 - Diagram of the single-phase electric circuit - S Push-button panel	
4.3.2 - Diagram of the three-phase electric circuit - S Push-button panel	
4.3.3 - Diagram of the single-phase electric circuit - Professional switch	
4.4 - FUNCTIONING CHECK	
CHAP. 5 - OPERATING OF THE SLICER	pag. 17
5.1 - CONTROLS	
5.2 - LOADING AND SLICING OF FOODSTUFFS	
5.3 - SHARPENING OF BLADE	
CHAP. 6 - ORDINARY CLEANING	pag. 20
6.1 - GENERAL FEATURES	
6.2 - SLICER CLEANING PROCEDURE	
6.2.1 - meat hopper cleaning	
6.2.2 - blade, blade guard and ring cleaning	

- 6.2.3 - sharpener cleaning of the sharpener
- 6.2.4 - deflector cleaning of the deflector

CHAP. 7 - MAINTENANCE AND USEFUL ADVICE	pag. 22
7.1 - GENERAL FEATURES	
7.2 - belt	
7.3 - feet	
7.4 - power supply cord	
7.5 - blade	
7.6 - grinding mole	
7.7 - lubrication of sliding guides	
7.8 - label of the push-button panel	
CHAP. 8 - MACHINE DISPOSAL	pag. 23
8.1 - PUTTING THE MACHINE OUT OF SERVICE	
8.2 - WEEE Waste of Electric and Electronic Equipment	

CHAP. 1 - INFORMATION ON THE SLICER

1.1 - GENERAL PRECAUTIONS

- The slicer must be operated only by highly qualified people who are fully aware of the safety measures described in this manual.
- In case of a personnel turn over, training is to be provided in advance.
- Although the slicer is equipped with safety devices in the dangerous points, it is recommended not to touch the blade and the moving components.
- Before starting cleaning and maintenance, disconnect the slicer plug from the supply socket.
- Assess the residual risks carefully when protection devices are removed to carry out cleaning and maintenance.
- Cleaning and maintenance require great concentration.
- A regular control of the electric supply cords is absolutely necessary; a worn-out or damaged cord can expose users to great electric shock hazard.
- If the slicer shows malfunctions, it is recommended not to use it and to abstain from trying to repair it; please call the “SERVICE CENTRE”.
- Do not use the slicer for frozen products, meat and fish with bones and any products other than foodstuffs.
- **Do not use the slicer without the help of the meat pusher, when the meat is nearly finished.**
- **Do not place yourself in a dangerous position, the blade may cause injuries.**
- The manufacturer is not liable in the following cases:
 - ⇒ if the slicer has been tampered by non-authorized personnel;
 - ⇒ if some parts have been substituted by non original spare parts;
 - ⇒ if the instructions contained in this manual are not followed **accurately**;
 - ⇒ if the slicer is not cleaned and oiled with the right products.

1.2 - SAFETY SYSTEMS INSTALLED IN THE SLICER

1.2.1 - MECHANICAL SAFETY SYSTEM

The mechanical safety system of the slicer described in this manual complies with EC directives **2006/42** and regulations **EN 1974**.

The safety system includes (see 1.3.3):

- blade guard;
- ring;
- cover;
- meat pusher;
- meat pusher knob with ring nut and spacer;
- hand cover on the meat hopper;
- carriage only removable when the thickness gauge is set in the “0” position, at the end of its travel and towards the operating side.

1.2.2 - ELECTRICAL SAFETY SYSTEM

The safety system installed to protect users against electrical risks is in compliance with EC directives **2006/95**, **2004/108** and **mod. 2006/**.

The slicer is equipped with:

- a micro-switch which stops the slicer in case the tie rod for blade guard is removed (*see FIG. n°1*); the micro-switch prevents from restarting the slicer if the guard has not been set in the switch-off position.
 - a relay in the control box which requires the restarting of the slicer when a power cut occurs.
- Even though CE professional slicers are provided with electrical and mechanical protections (when the slicer is working and for maintenance and cleaning operations), there are still **RESIDUAL RISKS** that cannot be eliminated completely; these risks are mentioned in this manual under **WARNING**. The blade and other parts of the machine can cause cuts and injuries.

1.3 - SPECIFICATIONS OF THE SLICER

1.3.1 - general description

Our firm has designed and manufactured the CE line of professional slicers to cut foodstuffs (as salami and meat) in order to guarantee:

- the highest degree of safety in functioning, cleaning and maintenance;
- the highest hygienic standards due to an accurate choice of materials and a smooth design of the slicer components which come into contact with products so as to obtain easy and total cleaning and easy disassembly;
- the greatest accuracy in cutting foodstuffs thanks to a cam mechanism;
- solidity and stability of components;
- the highest degree of noiselessness due to belt drive;
- great handiness.

1.3.2 - construction features

The professional slicers CE are made of an aluminium alloy (Peraluman Mg5) treated by anodic oxidation. This procedure guarantees high hygienic standards of the parts interested by the cut and resistance to acids, salts and oxidation processes.

The blade is made of chromium plated steel 100Cr6; it is grinded and hardened to guarantee an accurate and sharp cut of products also after it has been resharpened. The other components of the slicer are made of ABS, LEXAN, PLEXIGLAS and stainless steel AISI 430 or 304.

1.3.3 - Slicer components

M / M Vert.

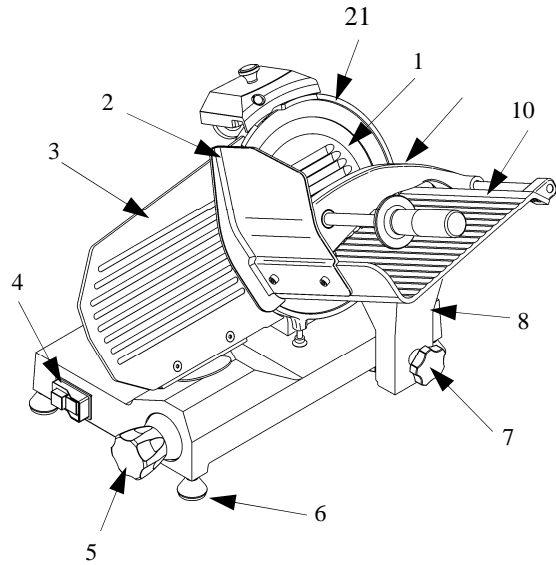

LEGEND:

- 1. Blade guard
- 2. Hand cover
- 3. Thickness gauge (plate)
- 4. Push-button panel
- 5. Dial knob
- 6. Feet
- 7. Carriage locking knob
- 8. Stem
- 9. Meat press
- 10. Meat hopper
- 11. Sharpener
- 12. Sharpener locking knob
- 13. Tie rod for blade guard
- 14. Power supply cord
- 15. Base
- 16. Rating plate - serial number
- 17. Thickness gauge support
- 18. Blade
- 19. Deflector
- 20. Meat press knob
- 21. Ring

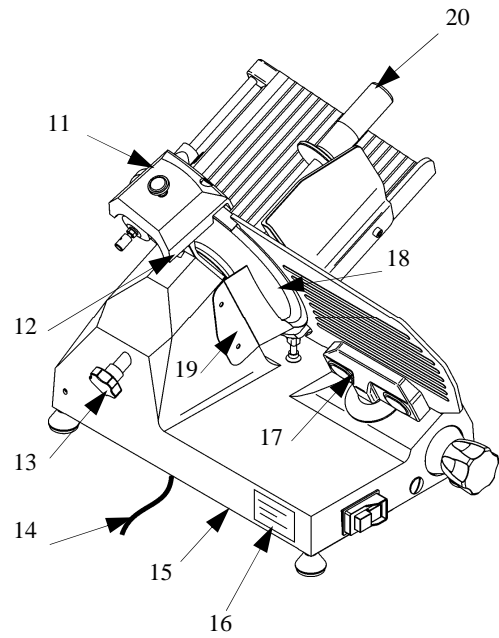
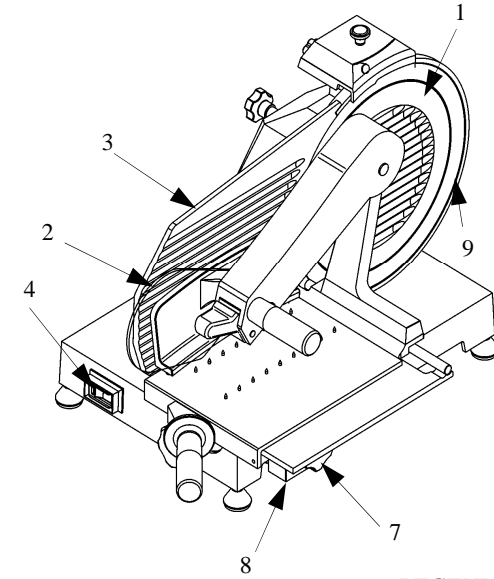

FIG. n°1a - General view of the slicer M / M Vert.

M Vert. BS



LEGEND:

- 1. Blade guard
- 2. Hand cover
- 3. Thickness gauge (plate)
- 4. Push-button panel
- 5. Dial knob
- 6. Feet
- 7. Carriage locking knob
- 8. Stem
- 9. Meat press
- 10. Meat hopper
- 11. Sharpener
- 12. Sharpener locking knob
- 13. Tie rod for blade guard
- 14. Power supply cord
- 15. Base
- 16. Rating plate - serial number
- 17. Thickness gauge support
- 18. Blade
- 19. Deflector
- 20. Meat press knob
- 21. Ring
- 22. BS Hopper push-handle

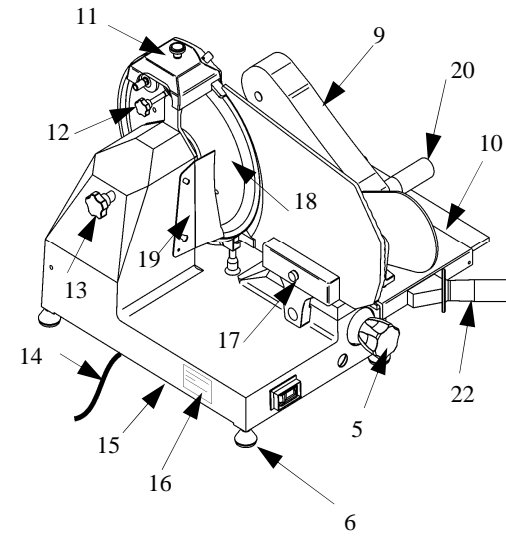

FIG. n°1b - General view of the slicer M Vert. BS

CHAP. 2 - TECHNICAL DATA

2.1 - OVERALL DIMENSIONS, WEIGHT, CHARACTERISTICS ...

FIG. n°2 - Drawings of the overall dimensions

M / M Vert.

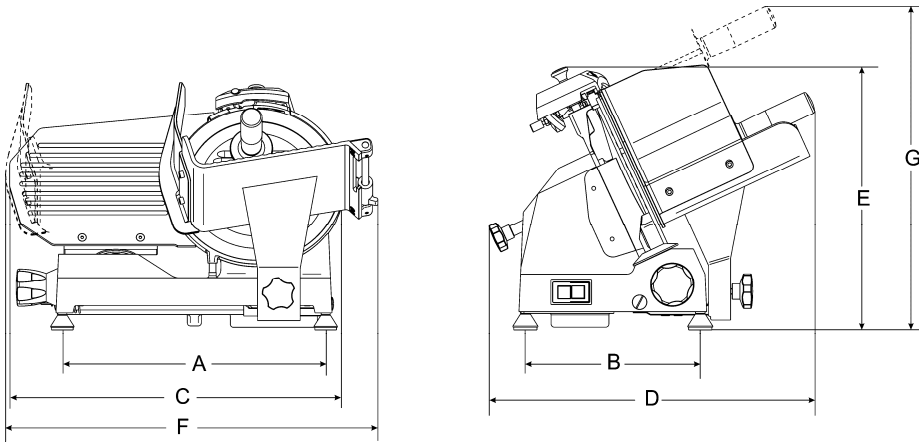

M Vert. BS

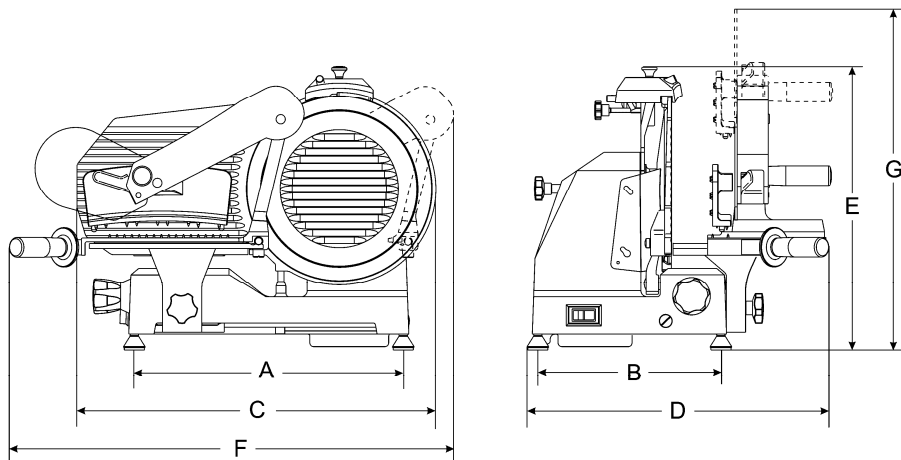

TAB. n°1 - OVERALL DIMENSIONS AND TECHNICAL CHARACTERISTICS.

MODEL	U.m.	M 220 C 220 AI C	M 250 C	M 275 C	M 300
Ø Blade	mm	220	250	275	300
Motor	W Hp	147 0,20	147 0,20	147 0,20	210 0,29
Power Supply	1Ph 3Ph	230V / 50Hz			230V / 50Hz 230-400V / 50Hz
Cut thickness	mm	13	13	13	13
Run of carriage	mm	245	245	245	285
Hopper size	mm	230x230	230x230	230x230	250x275
A x B	mm	395x245	395x245	395x245	435x295
C x D x E	mm	480x560x370	500x560x370	535x560x370	600x610x420
F x D x G	mm	570x560x475	570x560x475	570x560x475	640x610x510
X	mm	210	215	215	250
Y	mm	135	145	165	185
H	mm	170	180	200	225
W	mm	160	170	190	210
Net weight	Kg	15	16	17	20,5
Noise level	dB	≤ 60	≤ 60	≤ 60	≤ 60

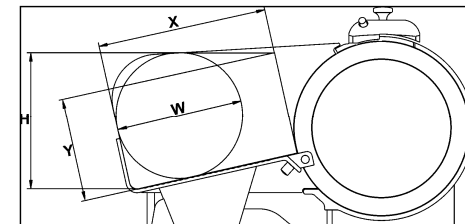

TAB. n°2 - OVERALL DIMENSIONS AND TECHNICAL CHARACTERISTICS.

MODEL	U.m.	M Vert. 220 C	M Vert. 250 C	M Vert. 275 C
ø Blade	mm	220	250	275
Motor	W	147	147	147
	Hp	0,20	0,20	0,20
Power Supply	1Ph	230V / 50Hz		
Cut thickness	mm	13	13	13
Run of carriage	mm	225	230	220
Hopper size	mm	230x235	230x235	230x235
A x B	mm	400x260	400x260	400x260
C x D x E	mm	500x535x400	510x535x410	530x535x420
F x D x G	mm	570x535x405	570x535x410	570x535x425
X	mm	205	205	225
Y	mm	150	170	205
H	mm	150	170	205
		W	150	170
Net weight	Kg	16,5	17,5	18,5
Noise level	dB	≤ 60	≤ 60	≤ 60

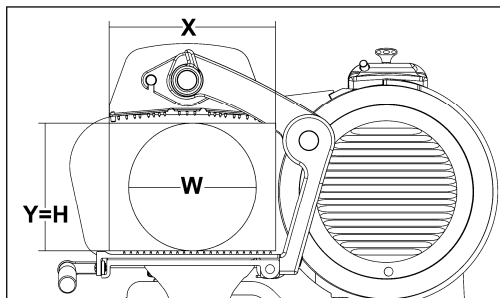

TAB. n°3 - OVERALL DIMENSIONS AND TECHNICAL CHARACTERISTICS.

MODEL	U.m.	M Vert. 250 C BS	M Vert. 275 C BS	M Vert. 275 BS	M Vert. 300 BS
ø Blade	mm	250	275	275	300
Motor	W	147	147	210	210
	Hp	0,20	0,20	0,29	0,29
Power Supply	1Ph 3Ph	230V / 50Hz	230V / 50Hz	230V / 50Hz	230V / 50Hz 230-400V / 50Hz
Cut thickness	mm	13	13	13	13
Run of carriage	mm	215	225	220	265
Hopper size	mm	275x270	260x275	285x260	260x275
A x B	mm	400x260	400x260	440x300	440x300
C x D x E	mm	510x480x415	530x480x420	580x500x455	585x540x460
F x D x G	mm	700x480x600	700x480x770	740x500x630	740x540x770
X	mm	270	270	255	255
Y	mm	190	200	205	215
H	mm	190	200	205	215
		W	190	200	205
Net weight	Kg	21,5	22,5	26	27
Noise level	dB	≤ 60	≤ 60	≤ 60	≤ 60

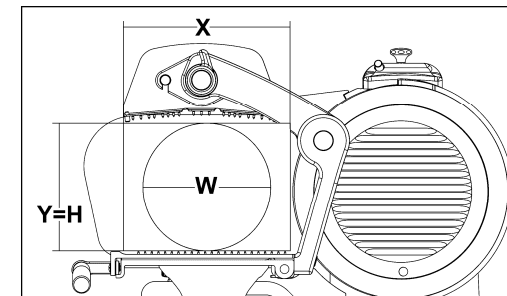

WARNING: Electrical features of the slicer are shown in the rating plate placed on the back side of the machine; before connecting the slicer to the electric system see § 4.2. **Electric connections.**

CHAP. 3 - SUPPLY OF THE SLICER

3.1 - DISPATCH OF THE SLICER (see FIG. n° 3)

Slicers are accurately packed and then dispatched from our warehouses; the package includes:

- a) a strong cardboard box;
- b) the slicer;
- c) two cardboard filling grafts to keep the slicer stable;
- d) this manual;
- e) an oil phial;
- f) EC conformity declaration.

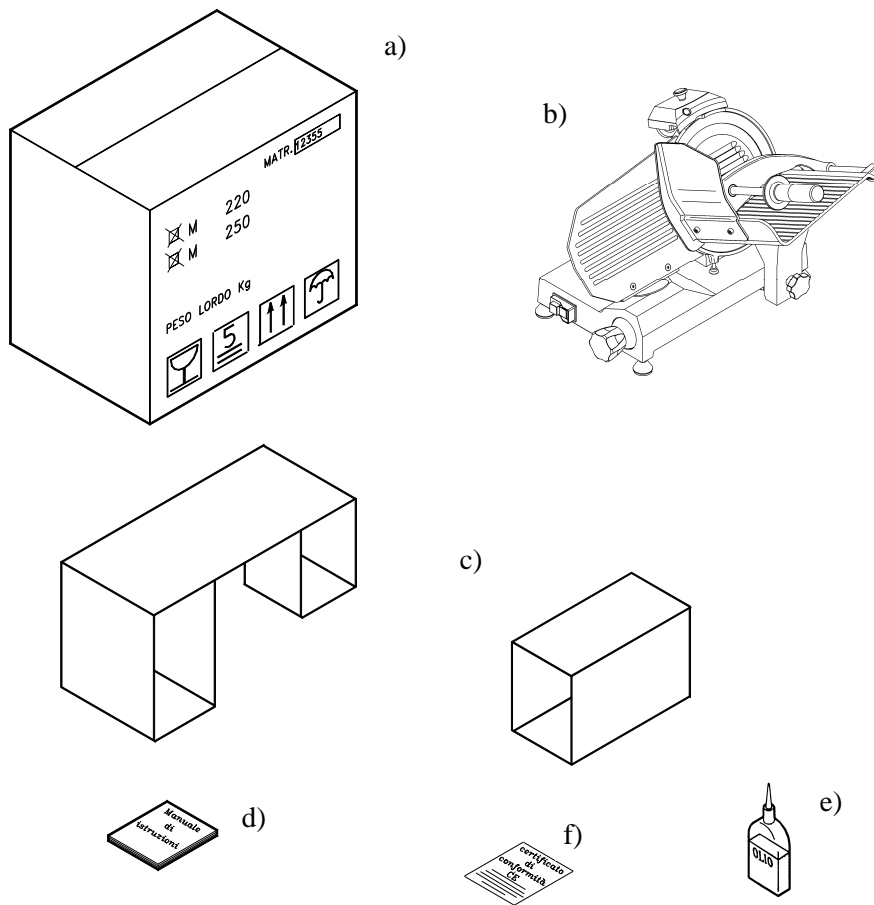

FIG. n°3 - Description of the package

3.2 - PACKAGE CHECK UPON ARRIVAL

If no external damage is evident on the package upon its arrival, open it and check that all the components are inside (see FIG. n°3). If the package has suffered from rough handling, bumps or crashes, the carrier must be informed about any damage; moreover a detailed report on the extent of the damage caused to the machine must be filled within three days from the delivery date shown in the shipping documents. **Do not overturn the package!!** When the package is transported, make sure, the box is lifted by the 4 corners (parallel to the ground).

3.3 - PACKAGING DISPOSAL

The components of the packaging (cardboard box, pallets, plastic straps and polyurethane) are urban solid waste; therefore they can be easily disposed.

If the slicer is to be installed in countries where specific regulations are in force, packaging must be disposed in compliance with them.

CHAP. 4 - INSTALLATION

4.1 - SETTING UP OF THE SLICER

The slicer must be installed upon a working table suitable for the slicer's overall dimensions shown in Table 1-2-3 (according to the model); therefore it must be adequately large, well levelled, dry, smooth, resistant, stable and placed at a height of 80 cm from the ground.

Moreover the machine must be installed in a room with max. 75% not saline humidity at a temperature between +5°C and 35°C; that is to say in a place that does not provoke the slicer failure.

4.2 - ELECTRIC CONNECTION

4.2.1 - slicer equipped with a single-phase motor

The slicer is equipped with a power supply cord (section of 3x1mm² and length of 1.5m) and a "SHUKO" plug.

Connect the slicer with a 230 Volt - 50 Herz electric circuit by interposing a differential-magnetothermic switch of 10A, $\Delta I = 0,03A$. Check that the earthing is fully operational.

Moreover check that features on the rating plate - serial number (FIG. n°4) correspond to the features shown in the consignment and delivery note.

4.2.2 - slicer equipped with a three-phase motor

The slicer is equipped with a power supply cord with a section of 5x1mm² and a length of 1.5m.

Connect the slicer with a 400 Volt - 50 Herz three-phase electric circuit by means of a CEI plug interposing a differential-magnetothermic switch of 10A., $\Delta I = 0,03A$.. Check that the earthing is fully operational. Before connecting the machine to the three-phase power supply circuit, check the direction of blade rotation by pushing the button "I" (ON) (see CHAP. 5.1 FIG. n°8) and immediately afterwards the cut-off button "0" (OFF).

The direction of blade rotation must be anti-clockwise looking at the machine from the blade guard side (see FIG. n°5).

Mod.	_____	_____	_____	_____	_____	_____	_____	_____	_____
Matr.	_____	_____	_____	_____	_____	_____	_____	_____	_____
	_____	H.p.	_____	A.	_____	Hz.	_____	_____	_____
○	_____	~	Volts.	_____	_____	Kg.	_____	○	_____
Anno	_____	_____	_____	_____	_____	_____	_____	_____	_____

FIG. n°4 - Rating plate - serial number

If the direction of rotation is wrong, reverse two of the three power supply cords in the plug or in the socket (black and grey).

Three-phase motors installed in CE professional slicers can work with both 230 V. three-phase tension and 400 V. tension.

Unless otherwise specified, connections are made with 400 V. power supply; call the "SERVICE CENTRE" if matching with the 230 V three-phase circuit. is required.

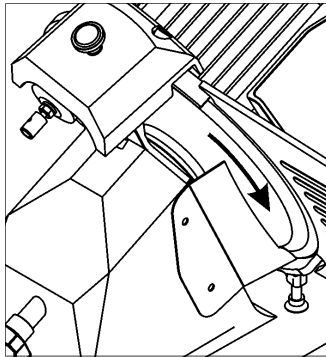

FIG. n°5 - Sense of blade rotation

4.3 - ELECTRIC CIRCUIT ARRANGEMENT

4.3.1 - arrangement of the single-phase electric circuit - Push-button panel

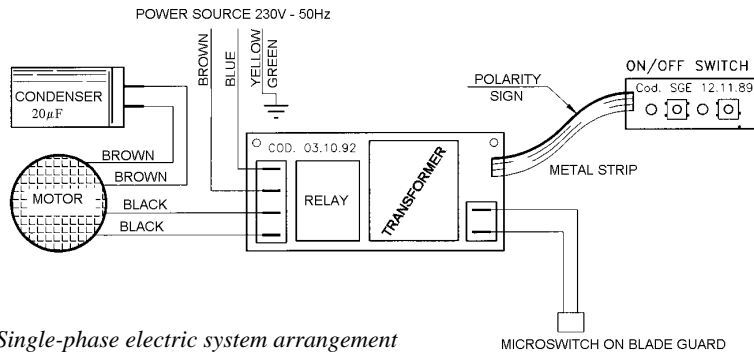
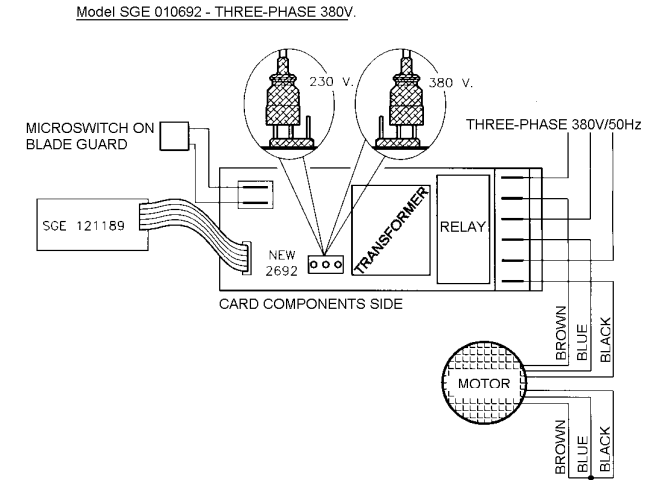

FIG. n°6 - Single-phase electric system arrangement

4.3.2 - arrangement of the three-phase electric circuit - Push-button panel



Model SGE 010692 - THREE-PHASE 230V.

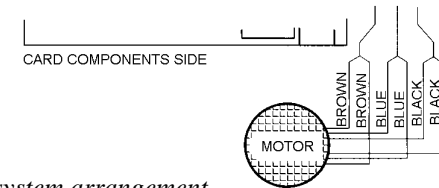

FIG. n°7 - Three-phase electric system arrangement

4.3.3 - arrangement of the single-phase electric circuit - Schalter Profi

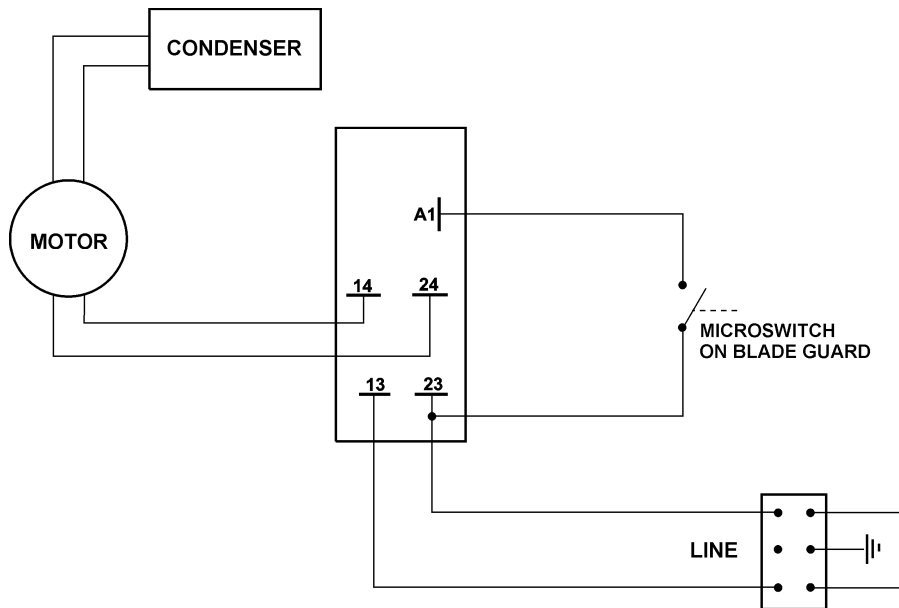

FIG. n°8 - Single-phase electric system arrangement - Schalter Profi

4.4 - FUNCTIONING CHECK

Before testing the slicer check that the meat hopper is blocked and then try the functioning according to the following procedure:

- 1 push the switch-on button "I" (ON) and the switch-off button "0" (OFF);
- 2 check the sliding of the meat hopper and meat pusher;
- 3 check the functioning and adjustment of the plate through the dial knob;
- 4 check the functioning of the sharper (see § 5.3, FIG. n°11 a-b-c);
- 5 check that the meat hopper can be disassembled only with the dial knob set in the "0" position and that, after disassembling the machine, the knob remains in this position;
- 6 check that the slicer stops functioning by unscrewing the tie rod for blade guard.

CHAP. 5 - OPERATING OF THE SLICER

5.1 - CONTROLS

Controls are placed on the left hand side of the base as shown in the picture above.

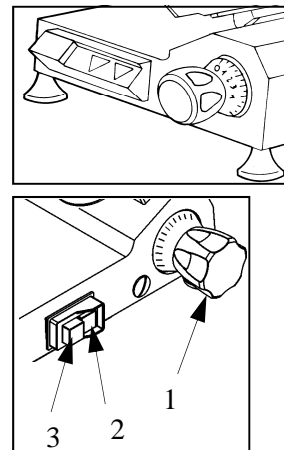

- 1 Dial knob to adjust the cutting thickness.
- 2 Switch-on button "I".
- 3 Switch-off button "0".

FIG. n°9 - Position of controls

5.2 - LOADING AND SLICING OF FOODSTUFFS

WARNING: Products to be cut must be loaded on the meat hopper only when the dial knob is set to the "0" position and pay attention to the blade and the sharp edges.

The procedure is as follows:

- 1 once the product has been loaded onto the meat hopper and placed against the plate, stop it with the arm provided with gripping points;
- 2 adjust the dial knob so as to obtain the desired cutting thickness;
- 3 to avoid accidents, the person who is cutting has to face the machine and stand correctly: put the right hand on the meat pusher, and then the left one beside the deflector (**do not touch the blade**); the body must be perpendicular to the working surface (see FIG. n° 10a). **WARNING:** Pay the maximum attention: no members of your body should enter in contact with the blade (see FIG. n°10b);
- 4 push the switch-on button "I";
- 5 smoothly push the carriage (meat hopper + meat pusher + stem) towards the blade without exerting pressure on foodstuffs with the meat pusher since they have their own force of gravity which exerts pressure on the thickness gauge. The blade will easily cut foodstuffs and slices will be guided by the deflector onto the collecting plate (see FIG. n°11);
- 6 do not operate the slicer without foodstuffs;
- 7 once foodstuffs have been cut, set the dial knob in the "0" position and switch off the machine by setting the switch to the "0" position;
- 8 sharpen the blade as soon as slices show a rough or frayed surface and the cutting becomes difficult (see 5.3).

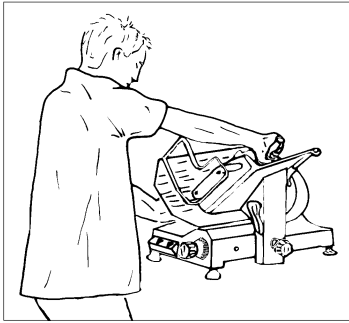

FIG. n°10a - Right position



FIG. n°10b - Bad position

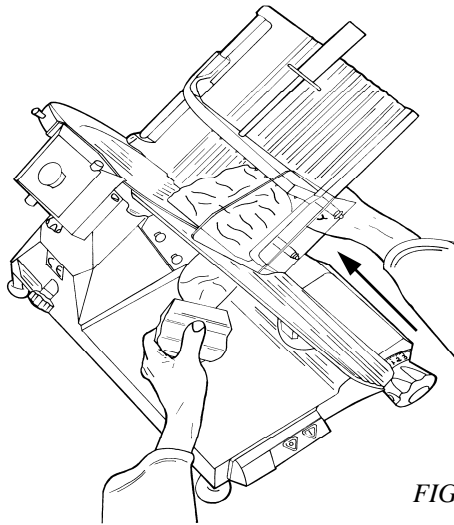

FIG. n°11 - Meat cut

5.3 - SHARPENING OF BLADE (see FIG. n°12 a-b-c)

WARNING: Before proceeding with blade sharpening, remain alert to the RESIDUAL RISKS (see §1.2.2) that refer to the hazard of injury if the instructions below are not followed.

The blade must be sharpened periodically and as soon as it becomes blunt; the following detailed instructions are to be carried out:

- 1 clean the blade accurately with denaturated alcohol to remove grease after the plug has been disconnected from the socket;
- 2 unscrew the knob (1), lift (a) the sharpener (2) up to the locking position and rotate it 180° (b) (see FIG. n°12a). Then let it move to the end (c) so that the blade is positioned between the two grinding moles. Lock the knob;
- 3 switch-on the slicer by pushing the button "I" (ON);
- 4 push the small button (3) (see FIG. n°12b), let the blade rotate against the grinding mole for 30/40 sec. to produce burr on the blade edge;
- 5 push buttons simultaneously for 3/4 seconds (3 and 4) and then leave them simultaneously (see FIG. n°12c);
- 6 it is recommended to clean the grinding moles by following the sharpening (see 6.2.3);
- 7 once sharpening has been completed, return the slicer to its original setting with the reverse procedure.

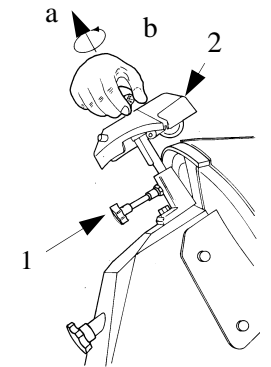

FIG. n°12a

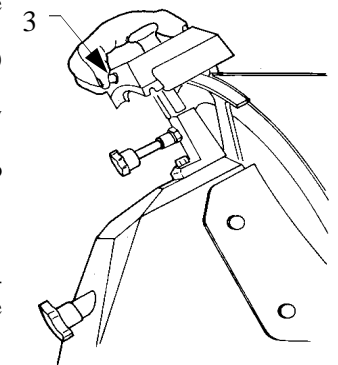

FIG. n°12b

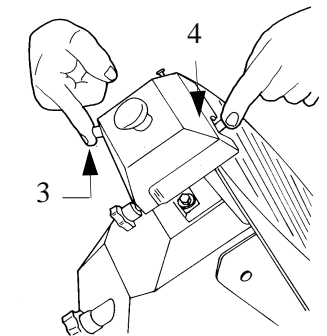

FIG. n°12c

NOTE: Do not prolong the burring operation beyond 3/4 sec. in order to prevent the dangerous twisting of the blade cutting edge.

CHAP. 6 - ORDINARY CLEANING

6.1 - GENERAL FEATURES

- The slicer cleaning must be carried out at least once a day or more frequently, if necessary.
- Cleaning must be extremely accurate for those parts of the slicer which are directly or indirectly in contact with foodstuffs.
- The slicer must not be cleaned with water-cleaners and high pressure jets of water, but use water and neutral detergent. **Do not use other detergents.** Tools, brushes and other devices likely to damage the slicer's surface must not be used.

Before carrying out any cleaning operation it is necessary to:

- 1) disconnect the power supply plug from the socket to isolate the slicer from the rest of the electric circuit completely;
- 2) set the dial knob adjusting the plate to the "0" position.

WARNING: Pay attention to residual risks due to cutting and/or sharp edges.

6.2 - SLICER CLEANING PROCEDURE

6.2.1 - meat hopper cleaning (see FIG. n°13)

The carriage (meat hopper + arm + stem) is easily removable:

- with the dial knob set in the "0" position (1);
- the carriage (2) at the end of its run (a) near the controls;
- unscrew the handwheel (3), slide the carriage upwards (b);
- after having removed the carriage, it is possible to clean accurately the meat hopper with hot water and neutral detergent (PH 7).

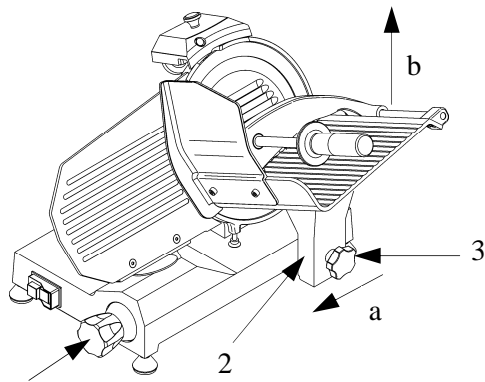

FIG. n°13 - Release of the carriage

6.2.2 - blade, blade guard and ring cleaning

Unscrew the knob of the tie screw (1) (see FIG. n°14) to release the blade guard (2).

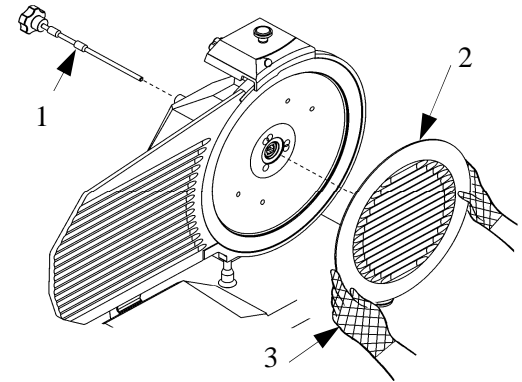

FIG. n°14 - Release of blade guard

WARNING: the blade cleaning must be carried out with metal gloves (3) and a wet cloth. To clean the blade on the opposite surface, it is necessary to remove the blade (see FIG. n°15).

The blade is to be removed as follows:

- 1) disassemble the blade cover (see FIG. n°14);
- 2) remove (a) the sharpener and open the thickness plate with the dial knob to make the blade removal tool (b) adhere to the blade;
- 3) loosen the 3 or 4 screws (f) (according to the model) that fix the blade;
- 4) lean the plexiglas blade removal tool on the blade to obtain the coupling of the blade holes with the two screws (e), turn the blade until it reaches the correct position;
- 5) tighten the screws (e) not excessively.

N.B. the blade guard must be cleaned with hot water and neutral detergent.

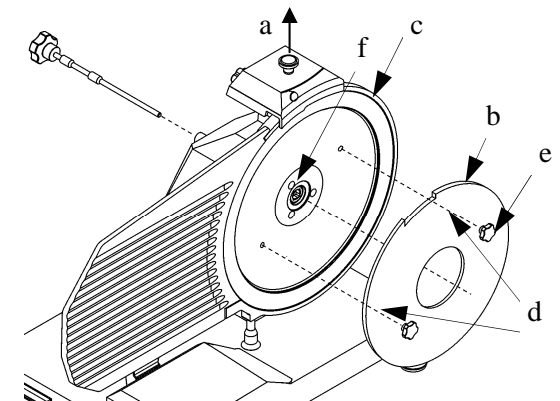

FIG. n°15 - Placing the mask in order to remove the blade

6.2.3 - cleaning of the sharpener

The sharpener cleaning operation is carried out by rubbing the grinding moles with a brush; the moles must be placed in the safety position which means that they must be turned towards the side opposite to the blade.

6.2.4 - cleaning of the deflector

The two screws (a) locking the deflector must be unscrewed to remove it (see FIG. n°16).

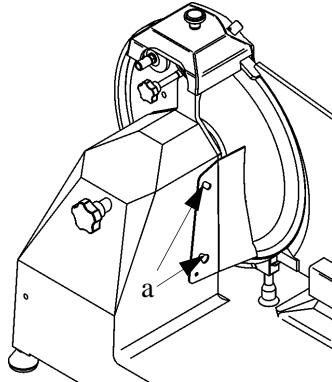

FIG. n.°16 - view of the

At this stage clean the deflector with hot water and neutral detergent.

CHAP. 7 - MAINTENANCE

7.1 - GENERAL FEATURES

Before starting maintenance it is necessary to:

- disconnect the power supply cord plug from the socket to isolate the slicer from the electric circuit completely.
- place the dial knob adjusting the thickness plate in the "0" position.

7.2 - BELT

The belt is not to be adjusted. Generally it must be replaced after 3/4 years; in this case please call your authorized "SERVICE CENTRE".

7.3 - FEET

Feet may deteriorate and lose elasticity thus reducing the stability of the slicer. In this case they must be replaced.

7.4 - POWER SUPPLY CORD

Periodically check whether the power supply cord is worn-out and, if this is the case, please call the "SERVICE CENTRE" to have it replaced.

7.5 - BLADE

Check that the blade does not lose more than 10mm of its original diameter. To have it replaced call the "SERVICE CENTRE".

7.6 - GRINDING MOLES

Check that the grinding moles retain their abrasive property during sharpening operations. If they must be replaced not to damage the blade; therefore call the "SERVICE CENTRE".

7.7 - LUBRICATION OF SLIDING GUIDES

From time to time pour some oil drops (from the oil phial provided with the slicer) onto the round bar along which the carriage slides back and forth; this operation can be carried out through the hole (OIL) next to the dial knob.

7.8 - LABEL OF THE PUSH-BUTTON PANEL

If the label of the push-button panel has been damaged, call the "SERVICE CENTRE" to substitute it.

CHAP. 8 - MACHINE DISPOSAL

8.1 - PUTTING THE MACHINE OUT OF SERVICE

If for some reason, you decide to put the machine out of service, make sure nobody can use it: **disconnect it from mains and eliminate the electrical connections**

8.2 - WEEE Waste of Electric and Electronic Equipment



Directive 2002/95/EC, 2002/96/EC and 2003/108/EC on the restriction of the use of certain hazardous substances in electrical and electronic equipment, and waste electrical and electronic equipment

This symbol, crossed out wheeled bin, on the product or on its packaging indicates that this product must not be disposed of with your other household waste.

Separate waste collection of this appliance is organised and managed by the manufacturer. It is the user's responsibility to contact the manufacturer and follow the waste treatment system the manufacturer has adopted for separate waste collection.

The separate collection and recycling of your waste equipment at the time of disposal will help to conserve natural resources and ensure that it is recycled in a manner that protects human health and the environment.