

07/2013

Mod: 350/AVV

Production code: 15354C4R12VHL



Diamond
catering equipment

CE Professional Slicer

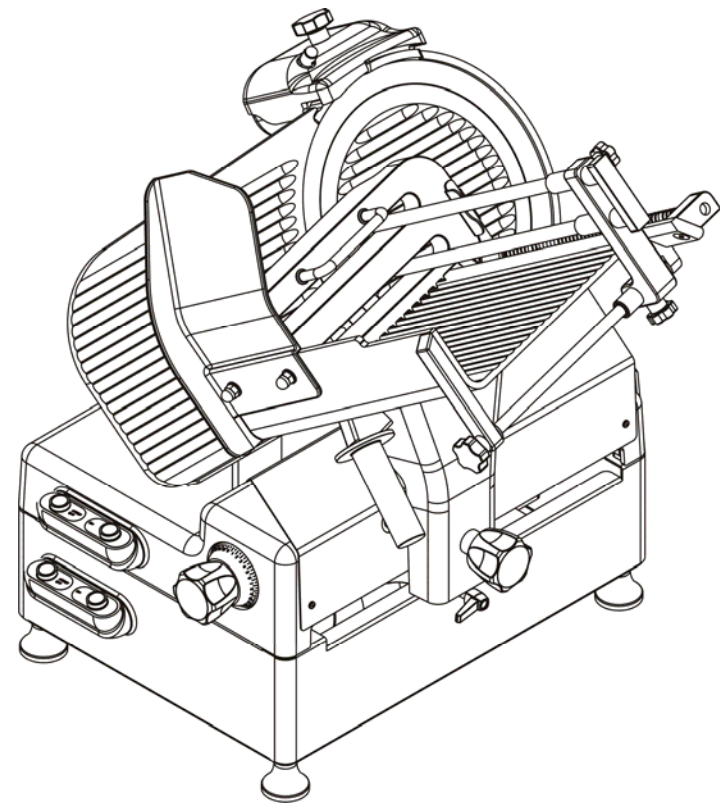

Ed. 01/2012

USE AND MAINTENANCE MANUAL

FOREWORD

- This manual is meant to provide Customers with information on the machine and its specifications, and provides all the necessary operating and maintenance instructions in order to ensure machine performance and longevity.
- This manual must be kept until the machine is disposed of.
- This manual should be accessible to all maintenance and operating personnel.

CONTENTS

CHAP. 1 - RECEIVING THE MACHINE page 4

- 1.1 - PACKAGING
- 1.2 - PACKAGING UPON DELIVERY

CHAP. 2 - INSTALLATION page 6

- 2.1 - UNPACKING
- 2.2 - POSITIONING
- 2.3 - ELECTRICAL CONNECTION
 - 2.3.1 - Slicer with single-phase motor
 - 2.3.2 - Slicer with 400 V. three-phase motor
 - 2.3.3 - Slicer with 230 V. three-phase motor
 - 2.3.4 - Blade rotation direction
- 2.4 - WIRING DIAGRAM
 - 2.4.1 - Single-phase 230 V. tension selection
 - 2.4.2 - Single-phase 230 V. tension selection VV
 - 2.4.3 - Three-phase 380 V. tension selection
 - 2.4.4 - Three-phase 380 V. tension selection VV
- 2.5 - CONTROLS
- 2.6 - PRELIMINARY CHECK

CHAP. 3 - INFORMATION ON THE MACHINE page 13

- 3.1 - GENERAL PRECAUTIONS

CHAP. 4 - CONSTRUCTION FEATURES page 15

- 4.1 - CONSTRUCTION FEATURES
- 4.2 - SAFETY DEVICES INSTALLED ON THE MACHINE
 - 4.2.1 - Mechanical safety
 - 4.2.2 - Electrical safety
- 4.3 - DESCRIPTION OF THE MACHINE
- 4.4 - OVERALL DIMENSIONS, WEIGHT, FEATURES....

CHAP. 5 - USING THE MACHINE page 20

- 5.1 - OPERATIONAL CHECK

- 5.1.1 - Using the controls
- 5.2 - LOADING AND CUTTING THE PRODUCT
- 5.3 - SHARPENING THE BLADE

CHAP. 6 - ROUTINE CLEANING page 24

- 6.1 - FOREWORD
- 6.2 - CLEANING THE MACHINE
 - 6.2.1 - Cleaning the goods holder plate
 - 6.2.2 - Cleaning the blade, the bladeguard and the ring
 - 6.2.3 - Cleaning the sliceguard
 - 6.2.4 - Cleaning the sharpener
- 6.3 - SLIDE GUIDES LUBRICATION

CHAP. 7 - MAINTENANCE page 27

- 7.1 - GENERALITIES
- 7.2 - BELT
- 7.3 - FEET
- 7.4 - FEEDING CABLE
- 7.5 - BLADE
- 7.6 - GRINDERS
- 7.7 - SLIDE GUIDES LUBRICATION

CHAP. 8 - DISMANTLING page 28

- 8.1 - PUTTING THE MACHINE OUT OF SERVICE
- 8.2 - WEEE Waste of Electric and Electronic Equipment

CHAP. 1 - RECEIVING THE MACHINE

1.1 - PACKAGING

The slicer is shipped (Fig. n°1) on wooden pallets and packed in a cardboard box and covered in protective nylon. Packaging materials must be disposed of separately and in conformity with waste treatment legislation of the country of destination.

| | Dimensions AxBxC | Net weight (Kg) |
|-----|---------------------|--------------------|
| 300 | 870x840x750 | 70 |
| 330 | 870x840x750 | 71 |
| 350 | 870x840x750 | 72 |

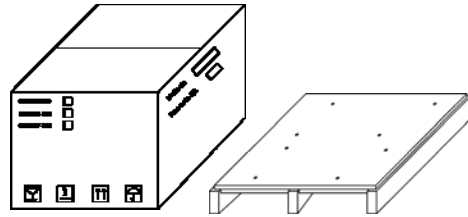

Fig. n°1

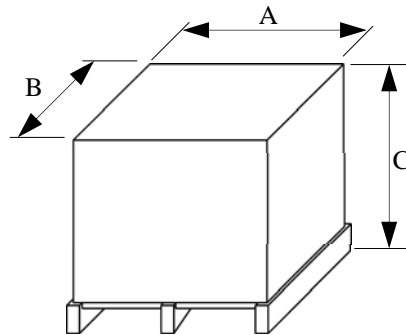

Fig. n°2



WARNING!

Do not stack more than one machine on top of another (Fig. n°3).

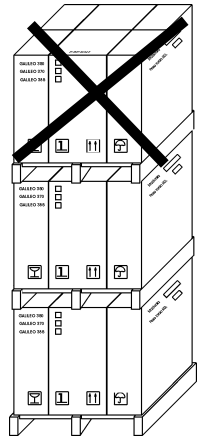

Fig. n°3



Do not expose the package to humidity or rain (Fig. n°4).

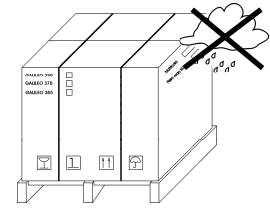

Fig. n°4



Heavyweight package. Do not manually lift without the help of at least three people (Fig. n°5).

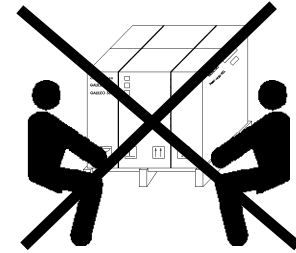

Fig. n°5



To handle and move the package use suitable manual or electric material handling equipment fitted with suitable lifting accessories (Fig. n°6).

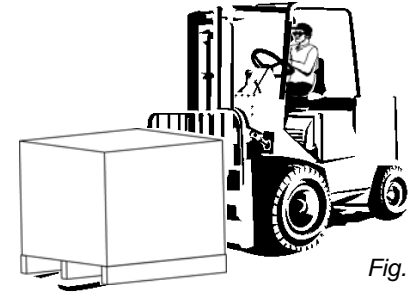

Fig. n°6



As the centre of gravity of the package is off-centre do not use lifting slings (Fig. 7) to move the package (Fig. n°7).

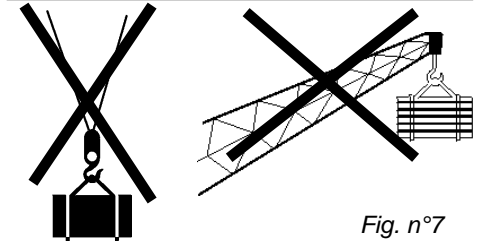

Fig. n°7

1.2 - CHECKING PACKAGING UPON DELIVERY

If packaging shows signs of damage caused during transport, the carrier must be informed immediately; moreover a detailed report on the extent of the damage caused to the machine must be notified to the carrier within three days from the delivery date on the shipping documents. If there are no

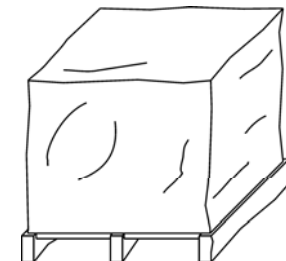

Fig. n°8

signs of damage, open packaging and check that all parts are included. Do not overturn the package!! When handling the packed slicer, make sure the box is lifted by the 4 corners (parallel to the ground).

CHAP. 2 - INSTALLATION

! WARNING!

All operations must be carried out by specialized personnel (Fig. n°9).



Fig. n°9

2.1 - UNPACKING

Remove straps from packaging (Fig. n°10) and remove the cardboard box (h). The package should contain:

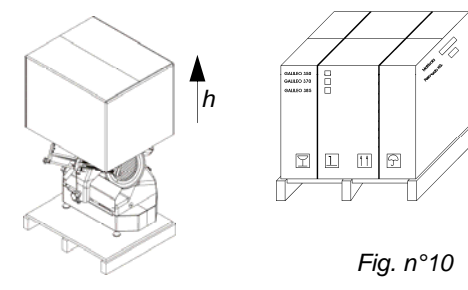

Fig. n°10

- machine on pallet (detail a);
- 4 feet (detail b);
- Instruction booklet (detail c);
- CE compliance certificate (detail d);
- blade extractor (detail e).

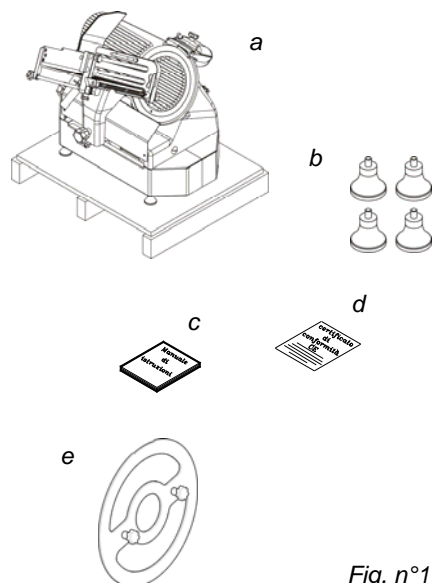

Fig. n°11

2.2 - POSITIONING

Position the pallet, with the slicer, on a flat surface and remove (a) the cap from the slicer (Fig. n°12).

Turn the machine on its side (Fig. n°13) and utilising the correct wrench provided unscrew the 4 nuts which secure the slicer to the pallet. Remove the 4 washers and unscrew the 4 fastening tie rods on the wooden pallet. Remove the pallet and fasten the 4 feet provided to the slicer. Finally, replace cap in its original position.

Position the slicer in its final operating location.

The dimensions indicated in Tab. 1 (which vary depending on model) must always be considered and taken into account for when deciding on the final location of the slicer. Slicer location must be sufficiently wide enough to accommodate the slicer, level, dry, smooth, robust, stable and at a height of approximately 80 cm from the ground and at least 20 cm from walls, objects, shelves, etc. (Fig. n°14) to allow for sufficient room to operate the slicer respecting and safeguarding operator safety.

Furthermore, the machine must be located in an environment with a maximum humidity of 75%, non-saline and with a temperature ranging between +5°C and +35°C; and in any event in environments which conform to the above specifications.

Make sure the graduated hand grip is in position "0".

Check alignment of the blade-thickness gauge by running a finger (Fig. n°16) from the blade towards the thickness gauge (never in the opposite direction).

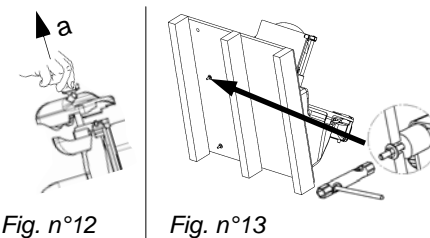

Fig. n°12

Fig. n°13

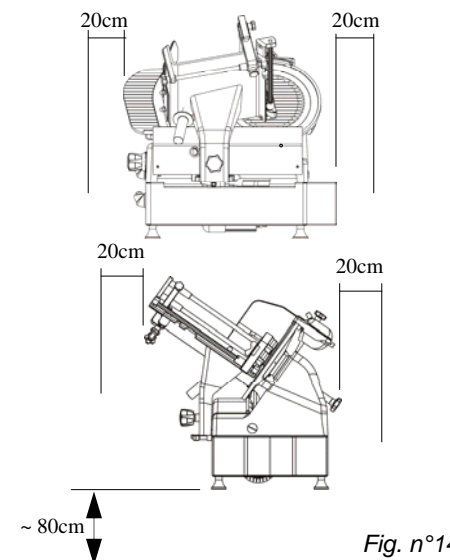

Fig. n°14

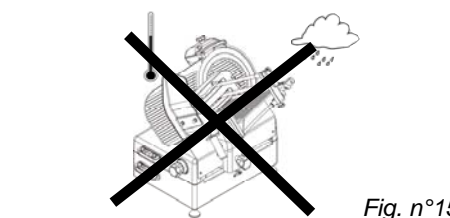

Fig. n°15

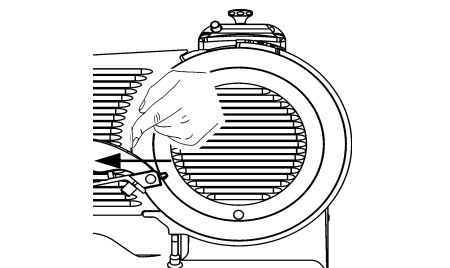

Fig. n°16

2.3 - ELECTRICAL CONNECTION

Check that the specifications provided in the rating plate -serial number (Fig. n°17) and in the consignment and delivery documents, correspond; if not contact the supplier immediately.
Check power supply cable and slicer earthing .

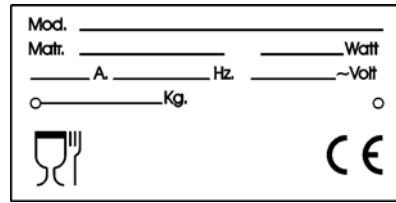

Fig. n°17

2.3.1 - Slicer with single-phase motor

The slicer is fitted with a power supply cable having a cross section of 3x1 mm²; approximate length 1.5m and a "SHUKO" plug. Connect the 230 V - 50 Hz slicer, interposing a 10 A ΔI= 0.03A thermomagnetic differential switch.

2.3.2 - Slicer with 400 V. three-phase motor

The slicer is fitted with a power supply cable having a cross section area of 5x1mm², approximate length 1.5m and a red 15A 3F + T CEI plug. Connect the slicer to the 400 V - 50Hz three-phase supply mains, interposing a 10 A ΔI= 0.03A thermomagnetic differential switch.

2.3.3 - Slicer with 230 V. three-phase motor

The slicer is fitted with a power supply cable having a cross section area of 5x1mm², approximate length 1.5m and a blue 15A 3F + T CEI plug. Connect the slicer to the 230 V - 50Hz three-phase supply mains, interposing a 10 A ΔI= 0.03A thermomagnetic differential switch.

Check blade rotation is anti-clockwise looking at the slicer from bladeguard side. If not proceed as in 2.3.4 .

2.3.4 - Blade rotation direction

Check the direction of the blade rotation with a pulse of the "I" push-button (ON), immediately followed by the "O" push-button OFF.

The direction of the blade rotation must be counter-clockwise when looking at the slicer from the bladeguard side (Fig. n°18). In the case that the rotation direction is not exact, invert

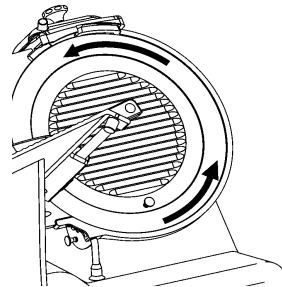

Fig. n°18

(Fig. n°19) the position of two of the three phase wires (black, gray or brown) in the plug.

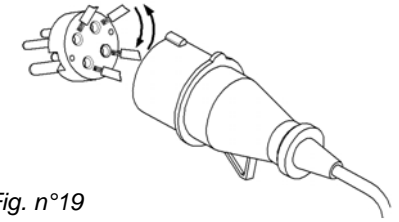

Fig. n°19

2.4 - WIRING DIAGRAM

2.4.1 - Single-phase 230 V. tension selection

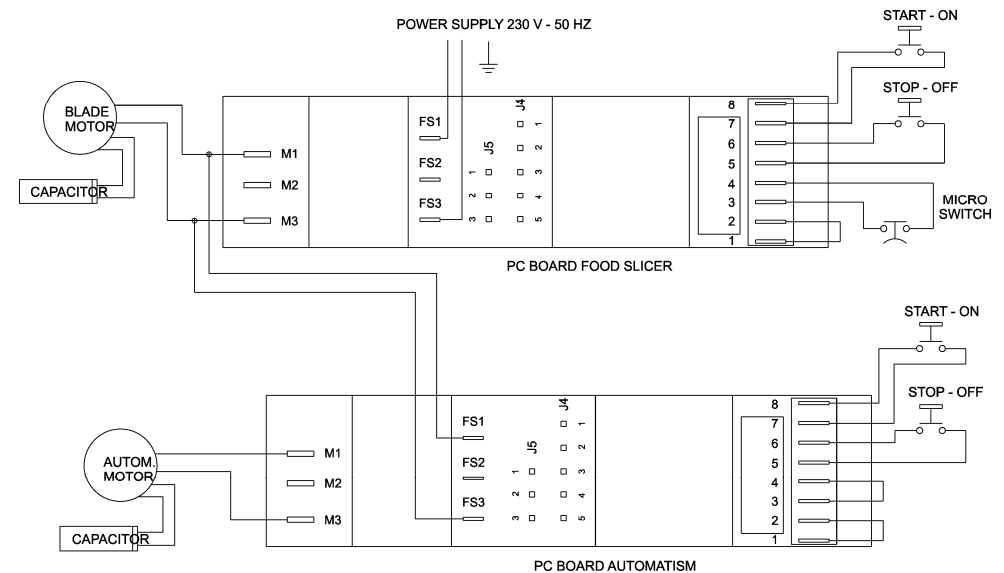

Fig. n°20

2.4.2 - Single-phase 230 V. tension selection VV

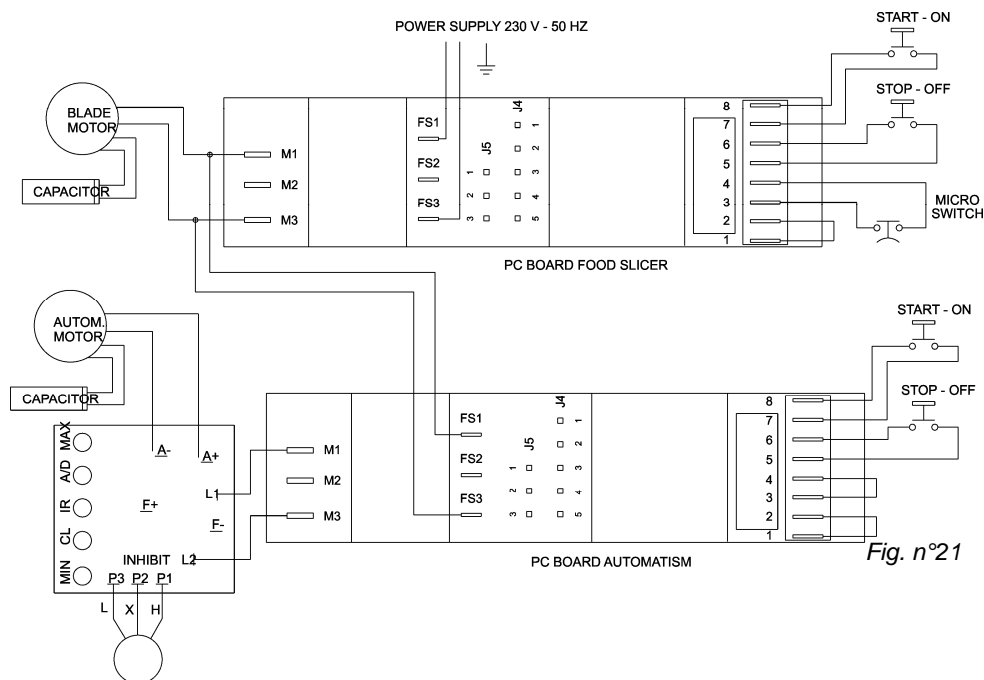

Fig. n°21

2.4.3 - Three-phase 380 V. tension selection

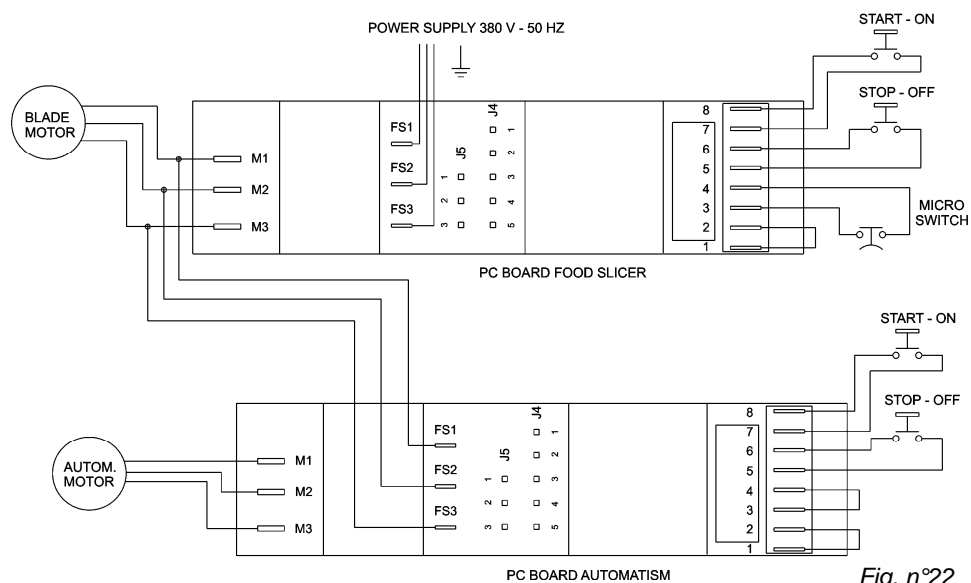

Fig. n°22

2.4.4 - Three-phase 380 V. tension selection VV

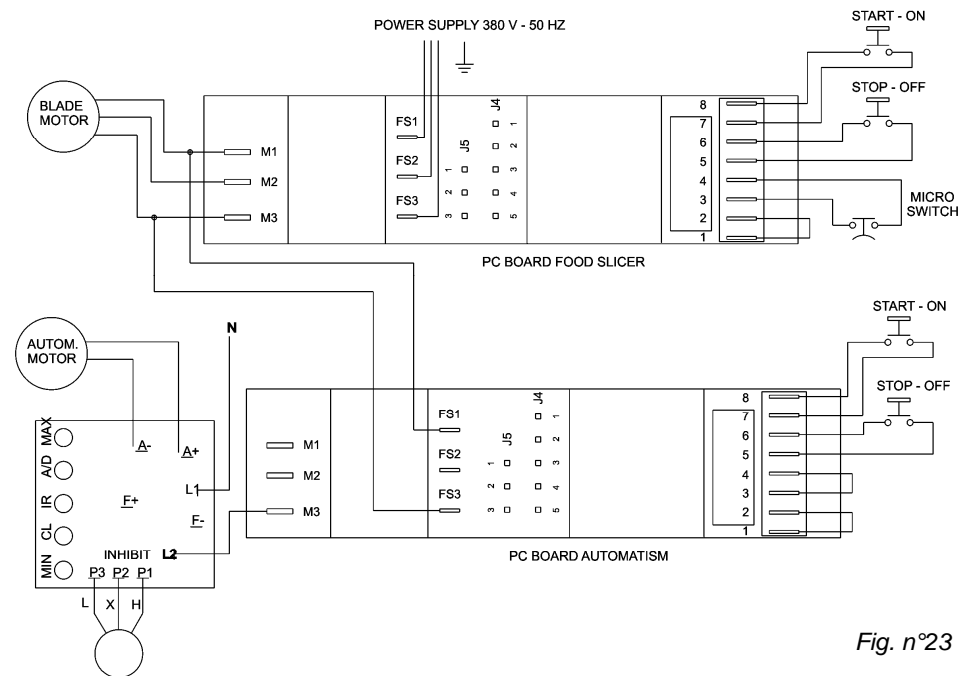

Fig. n°23

2.5 - CONTROLS

Controls of VV and Normal automatic slicer:

1. "I" blade ON push-button.
2. "0" blade stop push-button.
3. "I" carriage ON push-button.
4. "0" carriage stop push-button.

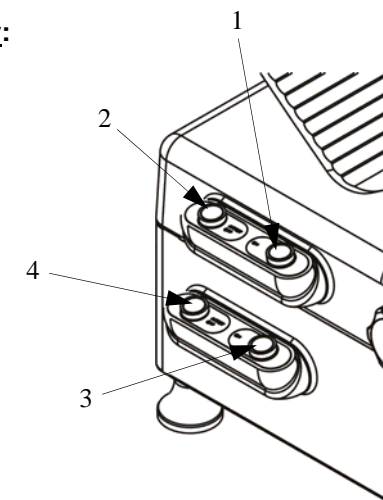
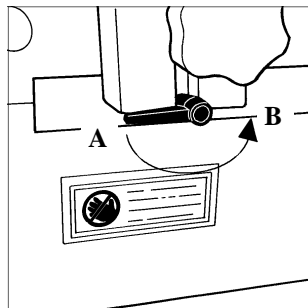

Fig. n°24

2.6 - PRELIMINARY CHECK (see FIG.n°25)

Before testing make sure the goods holder plate is well-blocked, after which test functioning with the following procedure:



Carriage lock/unlock lever

A - Carriage unlocked

B - Carriage locked

Fig. n°25

Manual operation mode

Unlock the carriage by turning the knob to position A (see FIG.n°25):

- check the manual sliding of the carriage
- press the switch-on (ref.1) and the switch-off (ref.2) of the blade (see FIG.n° 24);
- check that the slicer stops functioning by unscrewing the tie screw for blade guard (see FIG.n°33 - ref.21).
- with the machine running, unplug it and then plug it in again to check that it does not start-up automatically.

Automatic operation mode

Before carrying out testing, make sure the meat hopper is correctly locked with the knob in position B (see FIG. n° 25):

- press the switch-on (ref.1) and the switch-off (ref.2) of the blade (see FIG. n° 24);
- check the carriage functioning by pressing the switch-on (ref.4) and then the switch-off (ref.3) (see FIG. n° 24);
- check that the slicer stops functioning by unscrewing the tie screw for blade guard (see FIG.n°33 - ref.21).
- with the machine running, unplug it and then plug it in again to check that it does not start-up automatically.

CHAP. 3 - INFORMATION ON THE MACHINE

3.1 - GENERAL SAFETY PRECAUTIONS

The general precautions, although they appear obvious, are fundamental and must be respected when installing, using and servicing the machine and for dealing with possible malfunctions.

- The slicer has been designed to cut fresh boneless meat and pork products (Fig. n°26). Any other use, including slicing vegetables, is considered improper and therefore hazardous.
- The Manufacturer shall not be held responsible for:
 - ⇒ **the machine is tampered with by unauthorised personnel;**
 - ⇒ **components are replaced with non-original parts;**
 - ⇒ **the instructions in this manual are not followed carefully;**
 - ⇒ **machine surfaces are treated with unsuitable products.**
- Keep this manual in a safe and accessible place for future reference (Fig. n°27).
- The slicer must only be used by trained personnel who have knowledge of the safety standards provided in this manual.
- In the event of staff turnover, new operators must be properly trained .
- Do not allow the slicer to be used by children or by untrained people (Fig. n°28).

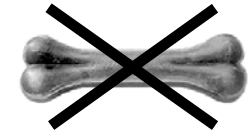

Fig. n°26



WARNING!



Fig. n°27

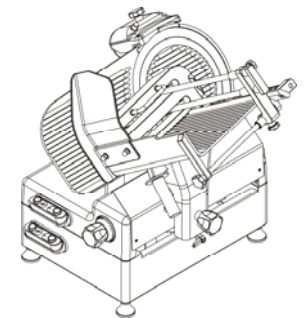

Fig. n°28



WARNING!

- Before performing cleaning or maintenance operations, disconnect the machine from the mains power supply.
- When performing routine maintenance or cleaning the slicer (the guards are removed), carefully evaluate all residual risks.
- During maintenance or cleaning it is of utmost importance that the operator is fully concentrated on the operations being performed.
- Do not use corrosive or flammable substances to clean the slicer (Fig. n° 29); only use the cleaning product provided (Fig. n°29);
- To clean the slicer carefully follow the instructions in the chapter: "Routine cleaning".
- Do not wash the slicer in a dishwasher (Fig. n°30) or with water jets, do not submerge it in water or in other liquids.
- Do not leave the slicer exposed to damaging agents such as sun, rain, liquid sprays, humidity, ice (Fig. n°31).
- Do not pull the slicer or the power supply cable (Fig. n°32) to unplug it.
- Regularly check the state of the power supply cable; a worn out cable or in any case not intact represents a serious electrical hazard.
- If the machine remains unused for long periods of time, before using it again have it overhauled and checked by a "Service Centre".

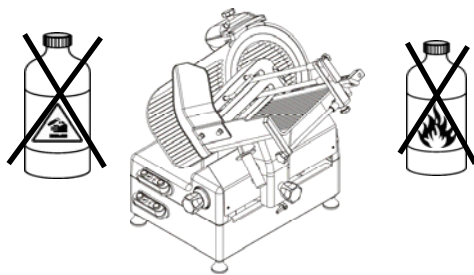

Fig. n°29

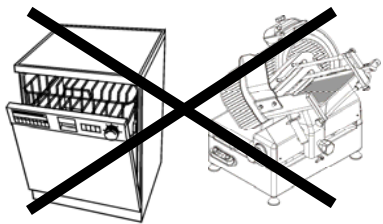

Fig. n°30

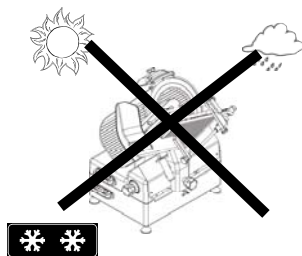

Fig. n°31

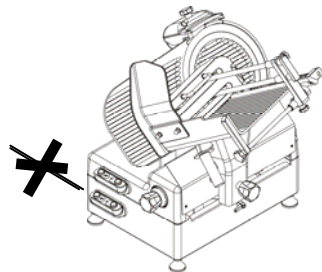

Fig. n°32

- If the slicer shows signs of malfunctioning, it is recommended to turn it off and not to use it, do not repair, but contact the "Service Centre", details are provided on the back cover of this manual.
- Do not leave the slicer plugged in if not in use. Always unplug the machine when it is not being used.
- Although safety devices are fitted to protect hazardous points on the machine, do not place hands near the blade and other moving parts.
- **Never slice the product without utilising the product pusher.**
- **Do not assume positions that cause parts of the body to come into direct contact with the blade.**

CHAP. 4 - GETTING FAMILIAR WITH THE SLICER

4.1 - CONSTRUCTION FEATURES

The slicer is made of an anodized aluminium alloy (Peraluman AlMg5) a food grade material (hygienic) which is acid and salt resistant as well as being highly resistant to oxidation.

The blade is in 100 Cr6, rectified chrome-plated and hardened steel ensuring slicing precision even after sharpening. The majority of the other components are in:

- ABS:
- shockproof plastic (handguard);
- AISI 430 or 304 steel.
- The edge and the inside frame are made of stainless steel .

LEGEND:

| | | | |
|----|---------------------------|----|------------------------------------|
| 1 | Cap knob | 14 | Knob for adjustable product holder |
| 2 | Sharpener cover | 15 | Blade protection ring |
| 3 | Handguard | 16 | Blade |
| 4 | Thickness gauge hopper | 17 | Blade guard |
| 5 | Foot | 18 | Product pusher |
| 6 | Graduated hand grip | 19 | Product pusher grip |
| 7 | Stem grip | 20 | Base |
| 8 | Stem | 21 | Blade guard tie rod hand grip |
| 9 | Mechanism lever | 22 | Shell |
| 10 | Stem knob | 23 | Deflector |
| 11 | Product hopper | 24 | Thickness gauge plate |
| 12 | Edge | 25 | Automatism control |
| 13 | Adjustable product holder | 26 | Blade control |

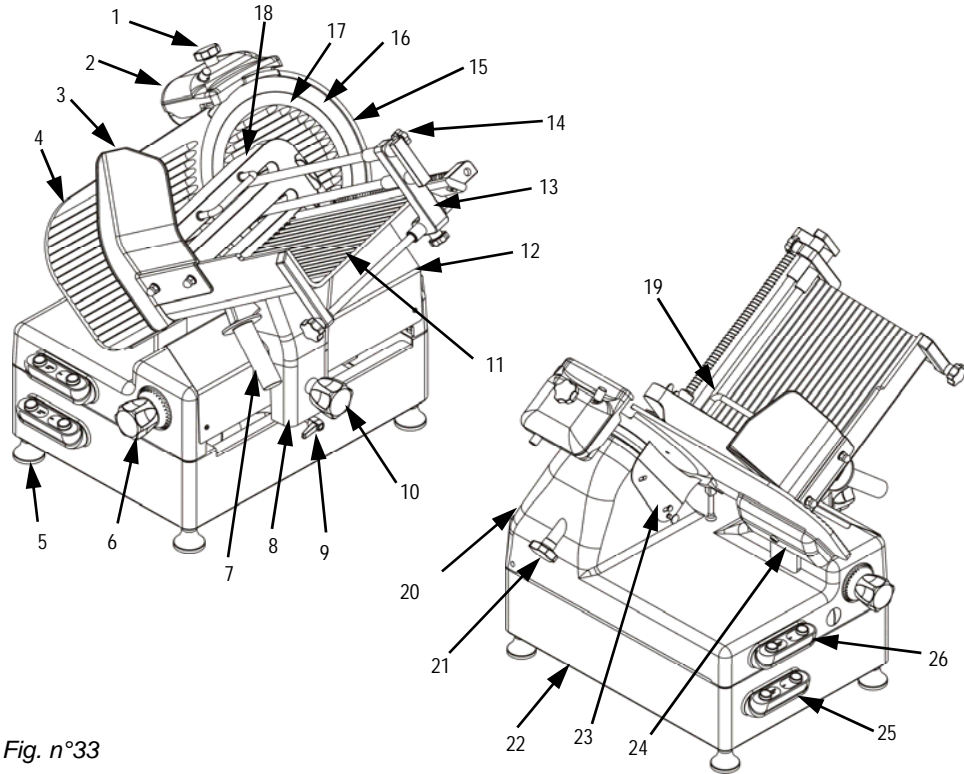

Fig. n°33

4.2 - SAFETY DEVICES INSTALLED ON THE MACHINE

4.2.1 - Mechanical safety

As far as mechanical safety is concerned, the slicer described in this manual responds to:

- CEE 2006/42 machine directives.

Safety is ensured by:
(Fig. n°34)

- Gauge plane (ref. n°1);
- Ring (ref. n°2);
- Cap (ref. n°3);
- Product pusher (ref. n°4);
- Handguard (ref. n°5);
- Trolley transported only when thickness gauge plane is at "0", at the end of the run and towards operator side.

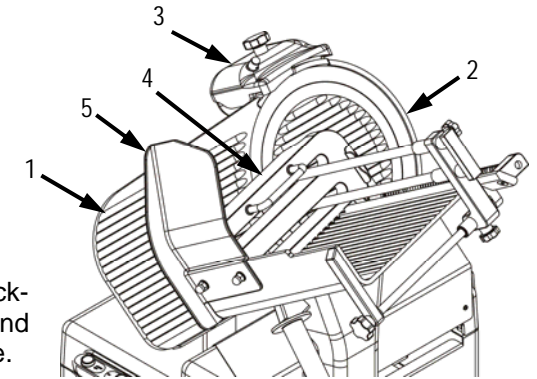

Fig. n°34

4.2.2 - Electrical safety

Concerning electrical safety, the slicer described in this manual responds to:

- EEC 2006/95 low tension directive;
- Directive 2004/108 electromagnetic compatibility.

The slicer is fitted with:

- a microswitch on the bladeguard causes the machine to stop if the bladeguard tie-rod is removed, and prevents the slicer from being turned on if the bladeguard is not properly closed (Fig. n°35);

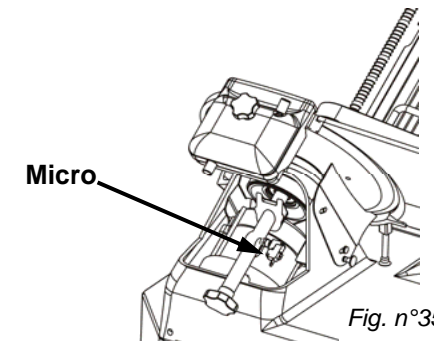

Fig. n°35

- A relay in the control circuit, that requires the machine to start up again in case of an accidental loss of electricity (Fig. n°36).

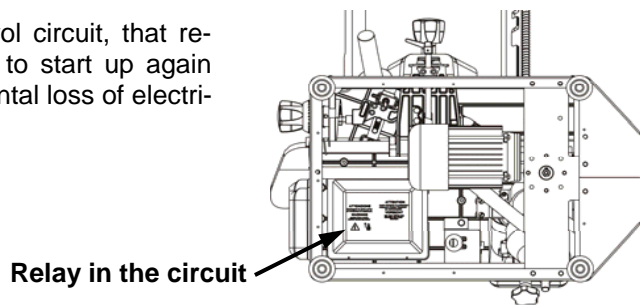

Fig. n°36

Although the professional **CE** slicers are equipped with standard measures for electrical and mechanical protection (for slicing and for cleaning and maintenance operations), **RESIDUAL RISKS** exist and cannot be completely eliminated. These risks are highlighted in this manual under the form of **WARNING**. They concern hazards related to cutting, bruising and other injuries caused by the blade or by other machine parts.

4.3 - DESCRIPTION OF THE MACHINE

Professional CE slicers have been designed and manufactured by our company with the precise purpose of slicing food products (cold meats and meat products) and they guarantee:

- maximum safety in use, cleaning and maintenance operations;
- maximum hygiene thanks to a meticulous selection of materials that come into contact with the food products, and by eliminating sharp edges which come into contact with the product facilitating cleaning and part removal;
- maximum slicing precision thanks to a cam mechanism;
- all components are of robust and stable construction;
- maximum silence thanks to the choice of belt transmissions;
- easy to handle.

4.4 - OVERALL DIMENSIONS, WEIGHT, FEATURES ...

WARNING:

The electrical specifications for the slicer are provided on the rating plate affixed to the rear of the machine.

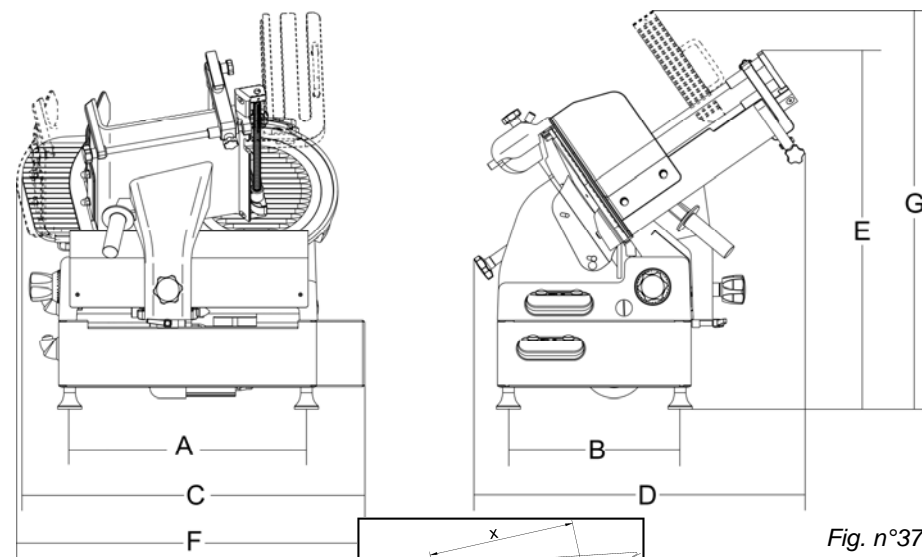

Fig. n°37

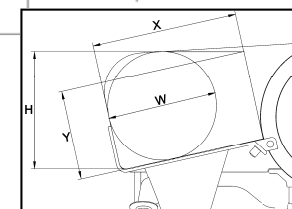

Fig. n°38

TAB. n°1 - DIMENSION MEASUREMENTS AND TECHNICAL FEATURES

| Model | U.m. | 300 | 330 | 350 |
|-------------------------|------------|--------------------------|--------------------------|--------------------------|
| Blade diameter | mm | 300 | 330 | 350 |
| AxB | mm | 465 x 340 | 465 x 340 | 465 x 340 |
| CxDxE | mm | 667 x 660 x 670 | 684 x 660 x 670 | 685 x 660 x 670 |
| FxDxG | mm | 685 x 660 x 750 | 700 x 660 x 750 | 700 x 660 x 750 |
| Hopper | mm | 365 x 270 | 365 x 270 | 365 x 270 |
| Run of carriage | mm | 310 | 310 | 310 |
| Cut capacity X Y H W | mm | 240/270 190 240 220 | 240/270 210 260 240 | 240/270 225 275 250 |
| Cut thickness | mm | 23 | 23 | 23 |
| Motor | Watt Hp | 275 + 180 0,37 + 0,24 | 275 + 180 0,37 + 0,24 | 275 + 180 0,37 + 0,24 |
| Net weight | Kg | 55 | 56 | 57 |
| Power source | | 230-400 V. / 50 Hz | | |
| Noise level | dB | ≤ 60 | | |

CHAP. 5 - USING THE MACHINE

5.1 - OPERATIONAL CHECK

When the slicer is used for the first time, proceed with the following instructions:

- check the slicer is correctly installed refer to chap. 2;
- check that the hopper is securely fastened utilising the lock knob (Fig. n°39 ref. 1);
- check the hopper travels freely and there are no obstacles on the counter (Fig. n°40 ref.a);
- check the product pusher can be raised and lowered easily and movement is not impeded in any way;

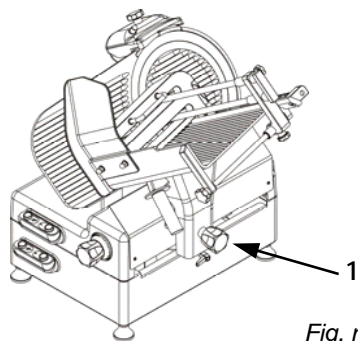

Fig. n°39

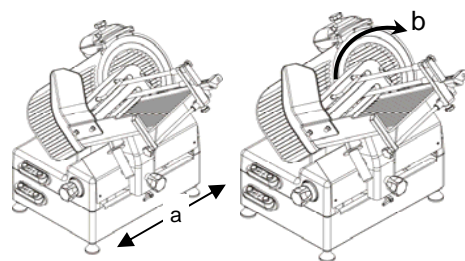

Fig. n°40

- check the thickness gauge opens and closes correctly by turning the thickness selection knob clockwise and anti-clockwise (Fig. n°41 ref.c);

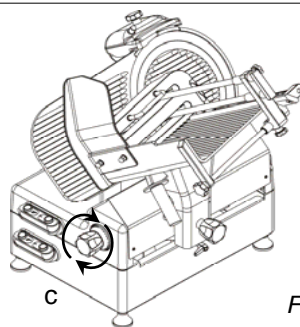

Fig. n°41

- check the sharpener is securely fastened to the machine and can be easily removed and free of obstacles (Fig. n°42 ref.d).



Fig. n°42

5.2 - LOADING AND CUTTING THE PRODUCT

WARNING: The goods to be cut are loaded on the hopper only with the graduated hand grip at "0" and the motor stopped, being careful with the blade and the points.

Proceed as follows:

1. position the adjustable product holder so as to leave sufficient space for loading the food product;
2. move the product pusher to the right so as to leave sufficient space for loading the food product.
3. load the food product;
4. move the adjustable product holder up against the food product and secure in place utilising the purpose knob (this prevents the product from moving when being sliced);
5. position the product pusher on the product (this product pusher is fairly heavy which facilitates slicing operations).
6. in the event there are several small sized food products to slice, it is possible to slice several products simultaneously.
7. if necessary purchase additional adjustable food product holders from your local authorised dealer.
8. utilising the thickness selection knob select required slicing thickness.

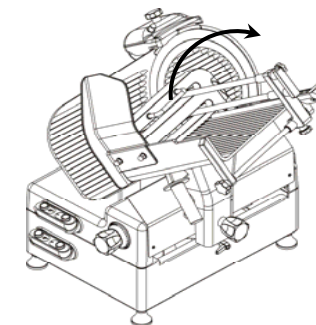

Fig. n°43

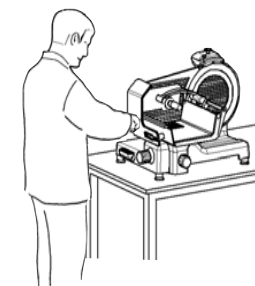

Fig. n°44

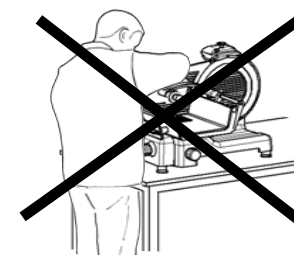

Fig. n°45

MANUAL SLICING

9. unlock the carriage by turning the knob in position A (cap. 2.6 FIG. n° 25);
10. stand in a correct position to prevent accident and injury; grip the product pusher with your right hand and position your left hand near the slice guard to retrieve the slices (do not touch the blade). Your body must always be vertical in respect to the counter top (Fig. n°44).

WARNING: Always stand in a

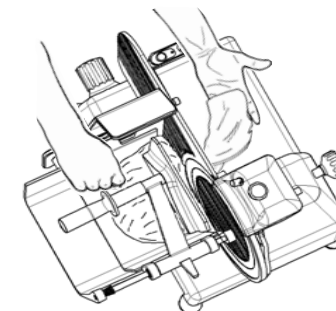

Fig. n°46

position so as to prevent parts of your body coming into contact with the blade (e.g. Fig. n°45);

11. push the "ON" pushbutton of blade;
12. push the hopper assembly (hopper + product pusher + stem) gently towards the blade, without applying excessive pressure on the product with the product pusher. The product pushed up against the blade is cut into slices which then pass through the slice guard (Fig. n°46);
13. do not use the slicer without a food product ;
14. after slicing the required amount of food product, stop the slicer by pressing the "OFF" pushbutton and turn the thickness selection knob to "0";
15. if the sliced product has a threaded or rough appearance, sharpen the blade to prevent creating excessive pressure in the blade (chap. 5.3).

AUTOMATIC SLICING

9. Lock the carriage by turning the knob in position B (cap. 2.6 FIG. n° 25).
10. Always stand in a correct position to prevent accident or injury: press the switch-on button "I" of the blade, then press the switch-on button "I" of the carriage (in the VV model it is possible to adjust the speed using a small knob). Stand in a correct position to prevent accident and injury; grip the product pusher with your right hand and position your left hand near the slice guard to retrieve the slices (do not touch the blade). Your body must always be vertical in respect to the counter top (Fig. n°44).

WARNING: Always stand in a position so as to prevent parts of your body coming into contact with the blade (e.g. Fig. n°45).

11. Do not use the slicer without a food product.
12. After slicing the required amount of food product, stop the slicer by pressing the "OFF" pushbutton and turn the thickness selection knob to "0".
13. If the sliced product has a threaded or rough appearance, sharpen the blade to prevent creating excessive pressure in the blade (chapter 5.3).

5.3 - SHARPENING THE BLADE

WARNING: Before proceeding with blade sharpening, evaluate **RESIDUAL RISKS** (chapter 4.2.2) concerning hazard of injury if the below instructions are not respected.

The slicer blade should be sharpened periodically the moment slicing precision and performance diminishes. To sharpen slicer blade follow and respect the below instructions:

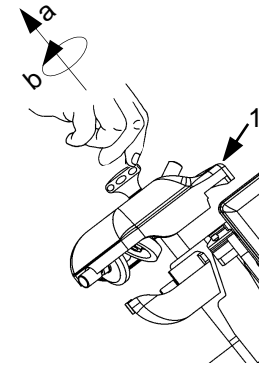

Fig. n°47

1. disconnect the plug from the socket and carefully clean the blade with denatured alcohol to remove any grease build-up;
2. lift (a) the sharpener cap (1) and turn it 180° (ref. b - Fig. n°47);
3. release the cap (c) so that it fits onto the locator pins (ref. d - Fig. n°48);
4. check that the blade is in between the two grinders;
5. connect the plug and press the "ON" pushbutton to start up the slicer.
6. press pushbutton ref. 2 - Fig. n°49 the blade should come into contact with the two grinders. Leave the blade to rotate for about 30/40 sec. so that a slight burr forms on the blade edge;
7. press the 2 pushbuttons - 2 and 3 - simultaneously for 3/4 sec. to dress the blade and then release (Fig. n°50);
8. after sharpening it is recommended to clean grinders and blade (chap. 6.2.3);
9. Once sharpening is completed, replace the sharpening device in its original position inverting the above procedure.

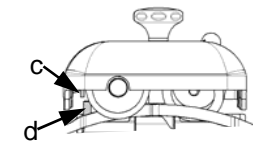

Fig. n°48

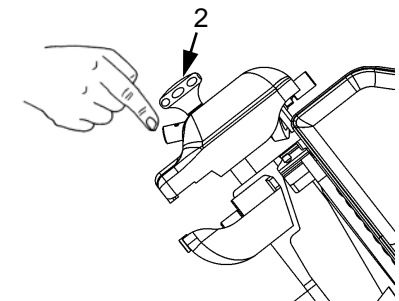

Fig. n°49

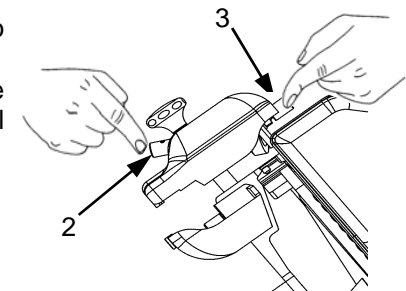

Fig. n°50

N.B.: Blade dressing should not exceed more than 3/4 sec. to prevent damaging the blade edge.

CHAP. 6 - ROUTINE CLEANING

6.1 - FOREWORD

- The slicer must be cleaned at least once a day and if necessary, more frequently.
- All the parts of the slicer that come into direct or indirect contact with the food product must be scrupulously cleaned.
- The slicer must not be cleaned with water cleaning machines or water jets, but with the product provided and/or with neutral detergents (pH 7). The use of any other detergent is prohibited. Utensils, brushes and or other tools must not be used which could damage machine surface .

Before cleaning always :

1. disconnect the plug from the mains power supply to completely isolate the machine from the mains network;
2. Turn the thickness selection knob to "0".

WARNING: evaluate residual risks due to sharp parts which could cause injury.

6.2 - CLEANING THE MACHINE

6.2.1 - Cleaning the hopper

see Fig. n°51

The hopper assembly (hopper + pusher + stem) is easy to remove:

- turn the thickness selection knob to "0" (1);
- move the hopper assembly (2) to end of travel (a) towards the controls; partially unscrew the hopper lock knob (3), pull the assembly towards the operator; completely unscrew the hopper lock knob, and then lift the assembly (4) (b);
- once the assembly is removed, the hopper can be cleaned with warm water and the detergent provided or with a warm water and neutral detergent (pH 7) solution Fig. n°52.

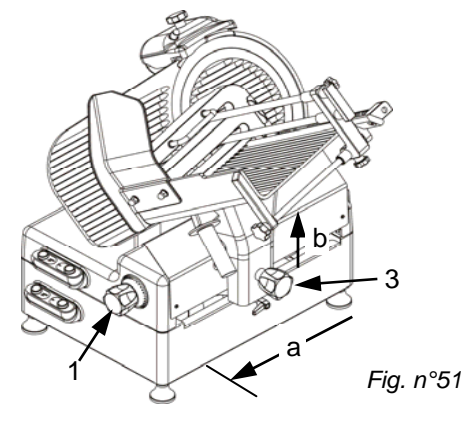

Fig. n°51



Fig. n°52

6.2.2 - Cleaning the blade, the bladeguard and the ring (see FIG.n°53-54-55)

WARNING: a pair of metal gloves must be worn when cleaning the blade (1) (Fig. n°53) and use a damp cloth.

Unscrew the hand grip from the bladeguard tie rod (1) and extract the bladeguard (2) using the proper grip to hold it (Fig. n°53). At this point it is possible to clean the blade Fig. n°54.

To clean the surfaces opposite the blade and the ring, the blade must be extracted in the following way:

- 1.unhook the bladeguard (Fig. n°53);
- 2.remove the sharpening device (Fig. n°55 ref. a) and open, utilising the thickness selection knob, the thickness gauge so that the jig (Fig. n°55 ref. b) adheres to the blade;
- 3.unscrew the three or four screws (Fig. n°55 ref. f), depending on the model, which fasten the blade in position;
- 4.position the jig (b) on the blade so that the split in the jig fits in the ring (Fig. n°55 ref. c);
- 5.match the axes of the two holes (Fig. n°55 ref.d) on the blade with the two knobs(Fig. n°55 ref.e) on the jig, simply making the blade turn to the desired position;
- 6.screw the two knobs (e) without excessively tightening them.

N.B. The bladeguard must be cleaned with warm water and the detergent provided or with a warm water and neutral detergent (pH 7) solution.

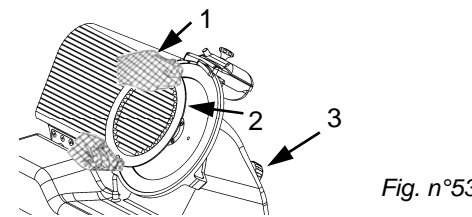

Fig. n°53

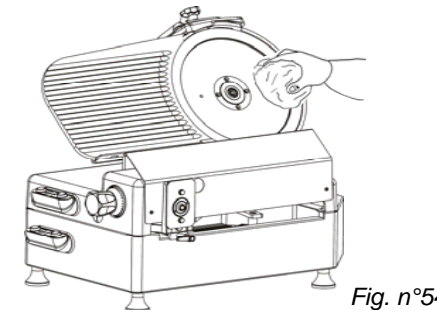

Fig. n°54

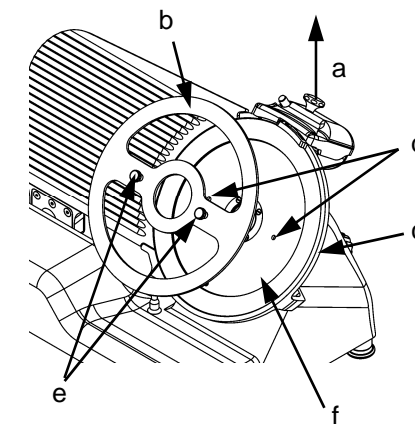

Fig. n°55

6.2.3 - Cleaning the sliceguard

(Fig. n°56)

To remove the sliceguard simply grasp the hand grip (1) and pull up so that the two pins unhook (2), and then extract the sliceguard.

At this point clean the sliceguard with warm water, the equipped detergent or with neutral detergent (pH 7).

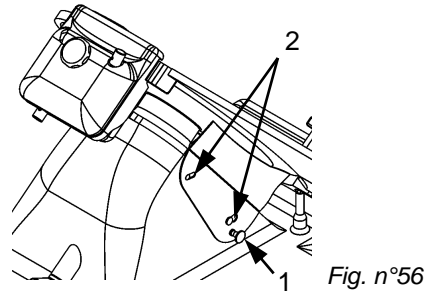

Fig. n°56

6.2.4 - Cleaning the sharpener

To clean the sharpener proceed as follows, Fig. n°57-58:

1. lift (a) the cap up to end of travel;
2. loosen the knob (1);
3. lift (b) the casing (2) and remove (1).

Make sure the knob passes through the largest opening in the casing (2);

4. rub the grinders with a brush. All other slicer components must be cleaned with warm water and the detergent provided or with a warm water and neutral detergent (pH 7) solution.

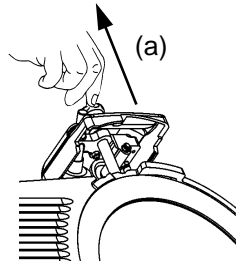

Fig. n°57

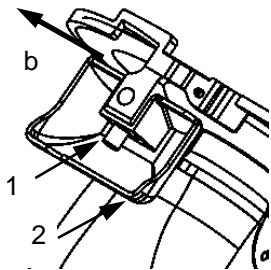

Fig. n°58

6.3 - SLIDE GUIDES LUBRICATION

The slide guides on the hopper assembly (1-2) must be lubricated periodically with the oil (a) provided in the kit (a).

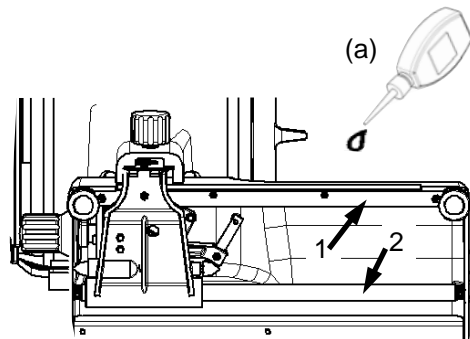

Fig. n°59

CHAP. 7 - MAINTENANCE

7.1 - FOREWORD

Before performing any maintenance operation:

- a) Disconnect the plug from the mains to isolate the slicer from the mains power supply.
- b) Turn the thickness selection knob to "0".

7.2 - BELT

The belt does not require adjustment. Generally after 3/4 years it must be replaced. Contact your local "SERVICE CENTRE" for replacement".

7.3 - FEET

The support feet can deteriorate in time and lose their elasticity, causing loss in stability. To replace contact your local "SERVICE CENTER".

7.4 - POWER SUPPLY CABLE

Periodically check for wear in the power supply cable. If the power supply cable shows signs of wear or damage contact you local "SERVICE CENTRE" for a replacement.

7.5 - BLADE

After numerous sharpening and dressing operations check blade diameter. The diameter must not exceed more than a 10 mm reduction tolerance in respect to the original diameter. Contact you local "SERVICE CENTRE" for a replacement.

7.6 - GRINDERS

Check that the grinders maintain their abrasive property during sharpening. Grinders that are no longer abrasive must be replaced to prevent damaging the blade. Contact you local "SERVICE CENTRE" for a replacement.

7.7 - SLIDING GUIDES LUBRICATION

Occasionally put a few drops of oil (from the tube provided) on the round bar the hopper assembly slides back and forth on, through the hole (OIL) located on the side of the thickness selection knob.

CHAP. 8 - SCRAPPING

8.1 - PUTTING THE MACHINE OUT OF SERVICE

For whatever reason, you decide to put the slicer out of service, make sure nobody can use it: disconnect it from the mains and eliminate electrical connections .

8.2 - WEEE Waste of Electric and Electronic Equipment



Directive 2002/95/EC, 2002/96/EC and 2003/108/EC on the restriction of the use of certain hazardous substances in electrical and electronic equipment, and waste electrical and electronic equipment

This symbol, crossed out wheeled bin, on the product or on its packaging indicates that this product must not be disposed of with your other household waste.

Separate waste collection of this appliance is organised and managed by the manufacturer. It is the user's responsibility to contact the manufacturer and follow the waste treatment system the manufacturer has adopted for separate waste collection.

The separate collection and recycling of your waste equipment at the time of disposal will help to conserve natural resources and ensure that it is recycled in a manner that protects human health and the environment.

**SERVICE CENTRE
AUTHORIZED DEALER**