

01/2015

Mod: **C520S/VT**

Production code: **TM52G-BLACK**



Diamond
catering equipment

Model:

TM32/TM42/TM52

TM32G/TM42G/TM52G



Absorption Minibar

UK Contents

Introduction	4
Important Safety Precautions	4
Installation	5
Product Parts and Features	6
How to Operate	6
Reversing The Door	7
Proper Absorption Minibar Care and Cleaning	7
Warranty	8
Disposal	8
Circuit Diagram	9



INTRODUCTION

Thank you for purchasing our absorption minibar. This unit is designed to improve your living and entertaining comfort. The absorption system minibar is a compact, totally silent refrigerator that uses no compressors or fans. Originally developed for use in hotel rooms, this kind of little refrigerator is available to use in many other locations, such as cruise line, caravan, department dormitory, office, etc. With its silent operation and attractive design, you will enjoy the convenience and comfort for years to come.

Please read these instructions carefully before operating this appliance. When using this appliance, always exercise basic safety precautions.

This easy-to-use manual will guide you to getting the best use of your absorption minibar.

IMPORTANT SAFETY PRECAUTIONS

Before you use your absorption refrigerator, please read this instruction manual carefully.

Use this appliance only for its intended purpose as described in this owner's manual.

This absorption refrigerator must be properly installed in accordance with the installation instructions before it is used.

Never unplug your absorption refrigerator by pulling on the power cord. Always grasp the plug firmly and pull straight out from the wall outlet.

1) Repair or replace immediately, all electric service cords that have become frayed or otherwise damaged. Do not use a cord that shows cracks or abrasion damage along its length, the plug or the connector end.

2) Unplug your absorption refrigerator before cleaning or before making any repairs.

NOTE: *If for any reason this product requires service, we strongly recommend that a certified technician perform the service.*

3) Do not operate your absorption refrigerator in the presence of explosive fumes.

4) The power supply must be properly grounded.

5) Do not use an adapter plug or extension cord.

6) Do not use the unit in the immediate surroundings of a bath, shower or swimming pool.

7) Before discarding or storing, we recommend that you remove the door and leave the shelves in place. This will reduce the possibility of danger to children.

8) Do not store food in absorption refrigerator as the interior temperature may not be cool enough to prevent spoilage.

INSTALLATION

It is advisable to clean the inside of the absorption refrigerator with lukewarm water using a mild detergent, and then to dry it thoroughly prior to use.

The temperature in the appliance will depend on:

The temperature in the room

The frequency and duration of periods when the door is open.

How many items are in the fridge

It may therefore be necessary to adjust the thermostat from time to time.

The refrigeration system of the cabinet is designed to operate with the cabinet located on a flat surface. Avoid tilting the cabinet side.

If the cabinet must be tilted on an angle for handling or moving purposes, allow it to sit in an upright position 20 to 30 minutes prior to plugging it in and starting the cooling of the storage compartment.

Grounding plug and socket should be provided in accordance with local regulations. The cable-size should meet the refrigerator's requirements. The unit must be connected to proper electrical network, which is shown on the nameplate, through an omnipolar circuit-breaker. To assure the proper function of the refrigerator, please observe the following recommended.

1. To ensure the circulation, the unit should be kept at 2 cm, away from the wall.
2. Locate the unit away from direct sunlight. This will enable you to obtain the best performance and save energy.
3. Under no circumstances should the top grid be covered by any object. It will preclude the warm air from circulating.

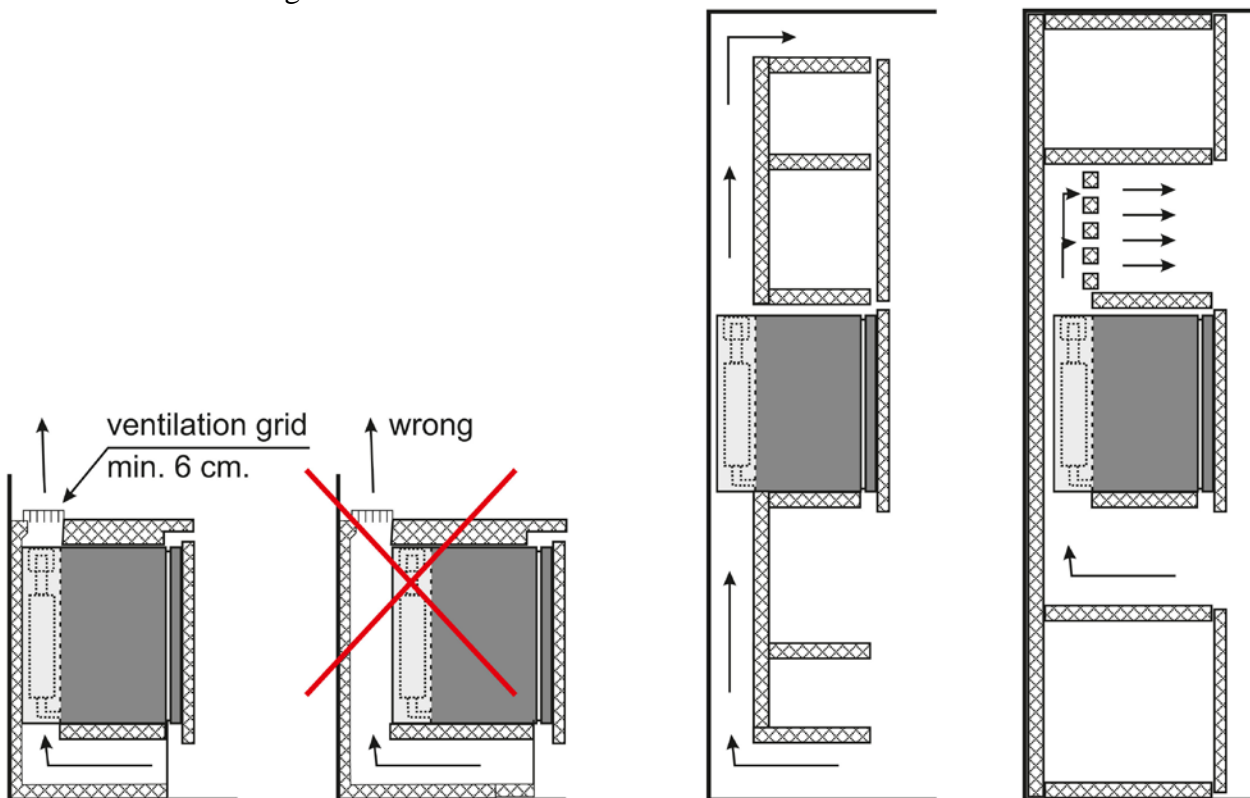

Installation Figure

PRODUCT PARTS AND FEATURES

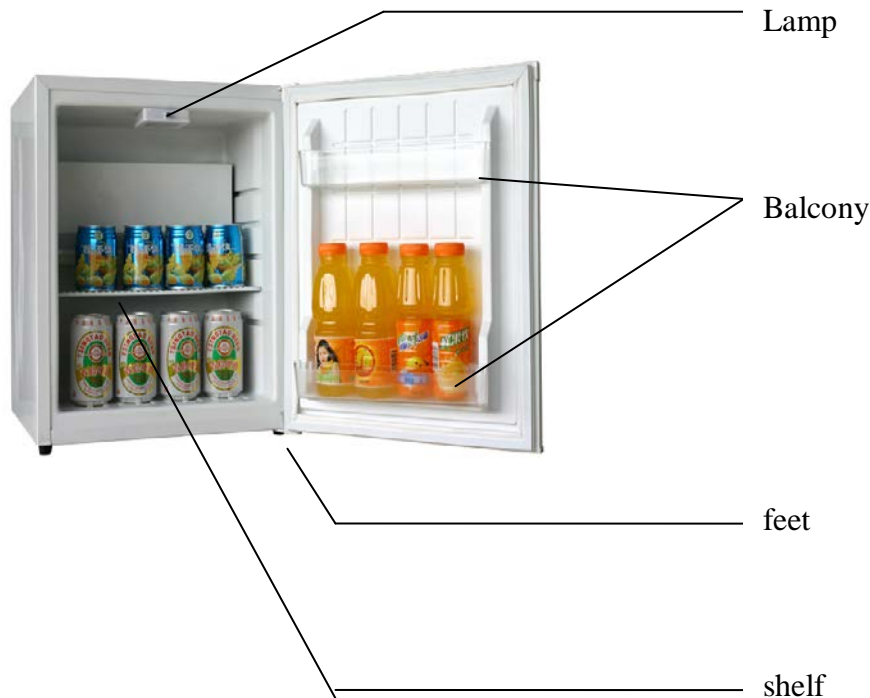

HOW TO OPERATE ABSORPTION MINIBAR

1. Insert the power plug into wall outlet.
2. To adjust the temperature turn thermostat knob inside the cabinet.

Automatic Defrosting



These models are with automatic defrosting system. It defrosts automatically every 24 hours.

Temperature Control



The control ranges from 0 to 6. Turn the thermostat knob till you have the desired temperature. Turn the knob clockwise, from 1 to 6, and you can get a lower temperature.

REVERSING THE DOOR

How to reverse the door

- Remove the lower hinge by loosening and removing the screws with scredriver.
- Carefully lower the door and remove it.
- Remove the two screws from the left top hinge position, take the metal part off the hinge position.
- Remove the two screws from the right top hinge and take off the hinge, insert the metal part, rivet the two screws thereafter.
- Take off the lower hinge and fix it to the opposite side.
- Take the door. Insert the lower hinge axle into the right bottom hole of the door.
- Fix the spare hinge to the left top position of the cabinet. Adjust the door, make it straight and in alignment with the cabinet.

Note: As the door gasket gets pressed-in during shipment, after reversing the door the gasket might have to be reset. This will be good for seal to avoid any air escaping. If there is a gap between the cabinet and the door gasket, set the gasket by gently pulling it out to seal the gap. If necessary, you are recommended also to use the hair drier to warm the gasket to get rid of the gap.

PROPER ABSORPTION MINIBAR CARE AND CLEANING

Warning: To avoid electric shock always unplug you absorption refrigerator before cleaning. Ignoring this warning may result in injury.

General: Do not use harsh chemicals, abrasives, ammonia, chlorine bleach, concentrated detergents, solvents or metal scouring pads. SOME of these chemicals may dissolve, damage and/or discolor your absorption refrigerator.

- 1) Remove the contents of the appliance
- 2) Wipe the inside and outside surfaces with a damp cloth. The addition of vinegar to the water is good for the prevention of mold and fungus.
- 3) Wipe all parts thoroughly after the cleaning.

IMPORTANT:

When the absorption refrigerator is not in use it must be completely dry inside to avoid mold growth (if possible have the door open).

LIMITED WARRANTY

As a condition to any warranty service obligation, the consumer must present this Warranty Certificate along with a copy of the original purchase invoice.

THIS WARRANTY DOES NOT COVER:

- 1) Damage, accidental or otherwise, to the absorption refrigerator while in the possession of a consumer not caused by a defect in material or workmanship.
- 2) Damage caused by consumer misuse, tampering, or failure to follow the care and special handling provisions in the instructions.
- 3) Damage to the finish of the case, or other appearance parts caused by wear
- 4) Damage caused by repairs or alterations of the absorption refrigerator by anyone other than those authorized by the manufacturer..
- 5) Freight and Insurance cost for the warranty service

ALL WARRANTIES, INCLUDING ANY IMPLIED WARRANTY OF MERCHANT ABILITY ARE LIMITED TO CLAIMED DURATION. THE MANUFACTURER DISCLAIMS ANY LIABILITY FOR CONSEQUENTIAL OR INCIDENTAL DAMAGES.

Disposal

Disposal of the cabinet must take place in an environmentally correct way. Please note existing regulation on disposal. There may be special requirements and conditions which must be observed.

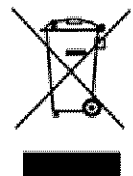

CIRCUIT DIAGRAM

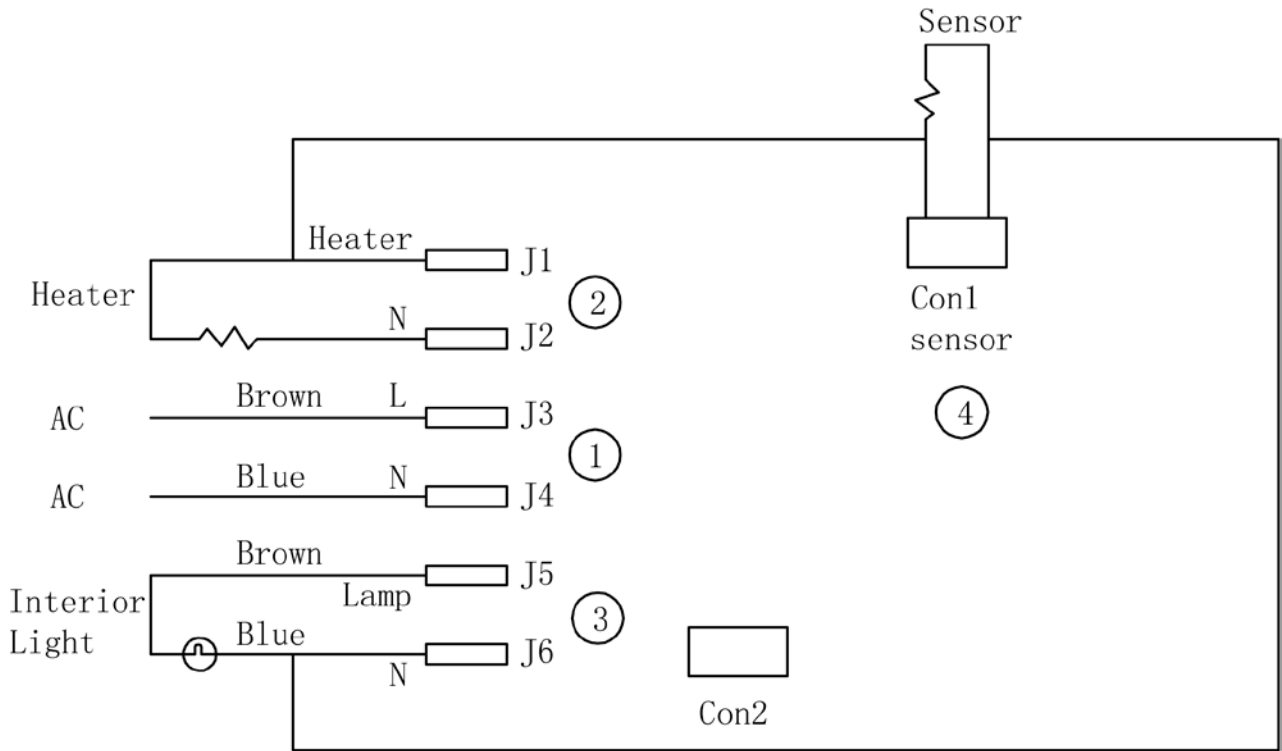

- | | |
|------------------|---------------------|
| ① AC Plug | ② Heater |
| ① Interior Light | ② Thermistor sensor |