

10/2016

# Mod: G60/GPL6T

Production code: 60/60 GRL



**Diamond**  
catering equipment



UK

## GRILL / GAS LAVA STONE GRILL Installation-Use-Maintenance



CE



MOD.

\_60/30 GRL  
\_60/60 GRL

\_65/40 GRG  
\_65/70 GRG  
\_65/40 GRL  
\_65/70 GRL

\_70/40 GRG...  
\_70/70 GRG...  
\_70/40 GRL...  
\_70/70 GRL...  
\_70/40 GRACQE  
\_70/70 GRACQE

\_90/40 GRL  
\_90/80 GRL  
\_90/40 GRACQE  
\_90/80 GRACQE

Doc.n°	252.445.00
Edition	01

<b>UK - INSTALLATION – USE - MAINTENANCE .....</b>	<b>16</b>
I. GENERAL PRESCRIPTIONS .....	16
1. DISPOSAL OF PACKING AND OF THE APPLIANCE .....	16
II. INSTRUCTIONS FOR INSTALLATION .....	17
2. REMINDERS FOR THE INSTALLER .....	17
3. REFERENCE STANDARDS AND LAWS .....	17
4. UNPACKING.....	17
5. POSITIONING.....	17
6. CONNECTIONS.....	18
7. CONVERSION TO ANOTHER TYPE OF GAS.....	19
8. COMMISSIONING .....	19
III. INSTRUCTIONS FOR USE .....	20
9. REMINDERS FOR THE USER .....	20
10. POSITIONING THE CAST IRON GRILLES .....	20
11. USING THE GAS GRILL.....	20
12. USING THE ELECTRIC GRILL.....	21
13. USING THE GAS LAVA STONE GRILL.....	22
14. PROLONGED DISUSE.....	22
IV. INSTRUCTIONS FOR CLEANING .....	22
15. REMINDERS FOR CLEANING .....	22
V. INSTRUCTIONS FOR MAINTENANCE .....	23
16. REMINDERS FOR THE MAINTENANCE TECHNICIAN.....	23
17. CONVERSION TO ANOTHER TYPE OF GAS.....	24
18. COMMISSIONING .....	24
19. TROUBLESHOOTING .....	24
20. REPLACING COMPONENTS .....	24
21. CLEANING THE INTERIOR.....	26
22. MAIN COMPONENTS.....	26
VI. SCHEMI DI INSTALLAZIONE – INSTALLATIONS PLAN - INSTALLATION DIAGRAM – SCHEMA D’INSTALLATION – ESQUEMA DE INSTALACION - INSTALLATIESHEMA'S .....	73
VII. FIGURE – ABB. – FIG. FIGURE-FIG.-IMAGE-ABB.-CIFRAS-AFBEELDINGEN.....	80
VIII. TAB1 - DATI TECNICI - TECHNICAL DATA - TECHNISCHE DATEN - CARACTERISTIQUES TECHNIQUES - DATOS TECNICOS - TECHNISCHE GEGEVENS UGELLI E REGOLAZIONI - NOZZLES AND SETTINGS - BUSES ET LES PARAMÈTRES - DUSEN UND EINSTELLUNGEN - BOQUILLAS Y LOS AJUSTES - VERSTUIVERS EN REGELINGEN .....	81
IX. TAB2 - DATI TECNICI - TECHNICAL DATA - TECHNISCHE DATEN - CARACTERISTIQUES TECHNIQUES - DATOS TECNICOS - TECHNISCHE GEGEVENS CATEGORIE E PRESSIONI - CATEGORIES AND PRESSURES - CATÉGORIES ET PRESSIONS - KATEGORIEN E DRUCK - LAS CATEGORÍAS Y LAS PRESIONES - CATEGORIEËN EN DRUK.....	84
X. TAB3 - DATI TECNICI - TECHNICAL DATA - TECHNISCHE DATEN - CARACTERISTIQUES TECHNIQUES - DATOS TECNICOS - TECHNISCHE GEGEVENS DATI TECNICI APPARECCHIATURE GAS - TECHNICAL DATA OF GAS APPLIANCES - CARACTÉRISTIQUES TECHNIQUES DES APPAREILS À GAZ - TECHNISCHE DATEN GASGERATE - DATOS TÉCNICOS DE LOS EQUIPOS DE GAS - TECHNISCHE GEGEVENS GASAPPARATUUR .....	85
XI. TAB4 - DATI TECNICI - TECHNICAL DATA - TECHNISCHE DATEN - CARACTERISTIQUES TECHNIQUES - DATOS TECNICOS- TECHNISCHE GEGEVENS DATI TECNICI APPARECCHIATURE ELETTRICHE - DATI TECNICI A TECHNICAL DATA OF ELECTRIC APPLIANCES - CARACTÉRISTIQUES TECHNIQUES DES APPAREILS ELECTRIQUES - TECHNISCHE DATEN ELEKTROGERATE - DATOS TÉCNICOS DE LOS EQUIPOS ELÉCTRICOS - TECHNISCHE GEGEVENS ELEKTRISCHE APPARATUUR .....	86

# UK - INSTALLATION – USE - MAINTENANCE

## I. GENERAL PRESCRIPTIONS



**READ THIS MANUAL CAREFULLY. IT PROVIDES IMPORTANT INFORMATION FOR SAFE INSTALLATION, USE AND MAINTENANCE OF THE APPLIANCE. FAILURE TO COMPLY WITH WHAT IS PRESENTED BELOW MAY COMPROMISE THE SAFETY OF THE EQUIPMENT.**



**THE MANUFACTURER WILL NOT BE LIABLE FOR ANY DAMAGE OR INJURY RESULTING FROM FAILURE TO OBSERVING THE FOLLOWING RULES.**



**TRANSLATION OF THE ORIGINAL INSTRUCTIONS.**



**APPLIANCES NEED PRECAUTIONS FOR INSTALLATION, PLACING AND/OR FIXATION AND CONNECTION TO THE MAINS. SEE SECTION “INSTALLATION INSTRUCTIONS”.**



**THE APPLIANCES NEED PRECAUTIONS FOR CLEANING. SEE THE SECTION “INSTRUCTION FOR CLEANING”.**



**THE SYMBOL “ HIGH VOLTAGE” IS PLACED ON A PANEL THAT GIVES ACCESS TO A PART WITH HIGH VOLTAGE.**

Keep this manual in a safe place, known to all users, so that it can be consulted throughout the working life of the appliance.

This equipment is designed for cooking food. It is intended for industrial use. Any other use is to be considered improper

This appliance is not intended for use by people (including children) with limited physical, sensory or mental abilities or without experience and knowledge of it.

Unless they are supervised or instructed in its use by a person responsible for their safety.

Do not leave the appliance unattended in presence of children and ensure that the latter do not have access to the appliance.

The appliance must be used by trained personnel. Do not leave the appliance unattended when operating.



**DO NOT STORE " AMMABLE MATERIALS IN CLOSE PROXIMITY TO THE APPLIANCE. FIRE HAZARD.**

The appliance must be installed in a well-ventilated room.

Inadequate ventilation causes asphyxia. Do not obstruct the ventilation system of the place where the appliance is installed. Do not obstruct the vents or ducts of this or other appliances.

In the event of an appliance fault or malfunction, shut the gas shut-off valve and/or switch the appliance off at the main switch installed upline.

Installation and conversion to a different type of gas must be carried out by qualified technicians authorized by the manufacturer, in compliance with current safety standards and the instructions in this manual.

Appliance maintenance and conversion to a different type of gas must be carried out by qualified technicians authorized by the manufacturer, in compliance with current safety standards and the instructions in this manual.

Clean the appliance following the instructions given in Chapter “ INSTRUCTIONS FOR CLEANING”.

## 1. DISPOSAL OF PACKING AND OF THE APPLIANCE

### PACKING

The packing is made using environmentally friendly materials. The plastic recyclable components are:

- the transparent cover, the bags containing the instructions manual and nozzles (made of

Polyethylene - PE).

- the straps (in Polypropylene - PP).

## APPLIANCE

- The appliance is manufactured 90% from recyclable metals (stainless steel, aluminium sheet, copper.. ..).
- The appliance must be scrapped in compliance with current regulations governing such disposal.
- Make the appliance unusable before scrapping.
- It must be disposed of properly.



**THE SYMBOL SHOWING A CROSSED-OUT WASTE CONTAINER ON THE UNIT OR PACKAGE INDICATES THAT, AT THE END OF ITS LIFE CYCLE, THE PRODUCT MUST BE COLLECTED SEPARATE FROM OTHER WASTE.**

**THE DIFFERENTIATED COLLECTION OF THIS EQUIPMENT IS ORGANISED AND MANAGED BY THE PRODUCER.**

**THE USER WHO INTENDS TO GET RID OF THIS EQUIPMENT SHALL CONTACT THE PRODUCER AND FOLLOW THE SYSTEM THAT THE LATTER HAS USED IN ORDER TO COLLECT THE EQUIPMENT SEPARATELY AT THE END OF ITS LIFE. PROPER SEPARATE COLLECTION HELPS PREVENT POSSIBLE NEGATIVE IMPACTS ON THE ENVIRONMENT AND HEALTH, AND FAVOURS THE REUSE AND/OR RECYCLING OF THE UNIT'S MATERIALS.**

**ABUSIVE DISPOSAL OF THE PRODUCT BY THE HOLDER WILL RESULT IN THE APPLICATION OF PENALTIES AS PER CURRENT STANDARDS.**

## II. INSTRUCTIONS FOR INSTALLATION

### 2. REMINDERS FOR THE INSTALLER



**READ THIS MANUAL CAREFULLY. IT PROVIDES IMPORTANT INFORMATION FOR SAFE INSTALLATION, USE AND MAINTENANCE OF THE APPLIANCE. FAILURE TO COMPLY WITH WHAT IS PRESENTED BELOW MAY COMPROMISE THE SAFETY OF THE EQUIPMENT.**



**THE MANUFACTURER WILL NOT BE LIABLE FOR ANY DAMAGE OR INJURY RESULTING FROM FAILURE TO OBSERVING THE FOLLOWING RULES.**

Identify the specific appliance model. The model number is detailed on the packing and on the appliance dataplate.

The appliance must be installed in a well-ventilated room.

Installation and conversion to a different type of gas must be carried out by qualified technicians authorized by the manufacturer, in compliance with current safety standards and the instructions in this manual.

Appliance maintenance and conversion to a different type of gas must be carried out by qualified technicians authorized by the manufacturer, in compliance with current safety standards and the instructions in this manual.

Do not obstruct any air vents or drains present on the appliance.

Do not tamper with appliance components.

### 3. REFERENCE STANDARDS AND LAWS

- Install the appliance in accordance with the safety standards in force in the country.

### 4. UNPACKING

- Check the state of the packing and in the event of damage, ask the delivery person to inspect the goods.
- Remove the packing.
- Remove the protective film from the outer panels. Use a suitable solvent to remove any residual adhesive from the panels.

### 5. POSITIONING

The overall dimensions of the appliance and the position of connections are given on the installation diagram at the end of this manual.

The appliance can be installed singly or in combination with other appliances in the same product range.

The appliance is not suitable for integrated installation.

Position the appliance at least 10 cm from adjacent walls.

If the appliance is to be placed near walls, dividers, kitchen furniture, decorative elements etc. this must be made of non-combustible materials. Otherwise, they must be covered with suitable non-combustible heat insulating materials. Level the appliance by means of the height-adjustable feet.

### APPLIANCE ASSEMBLY WITH BASE AND BRIDGE

Follow the instructions provided with the type of support utilized.

### FUMES EXHAUST SYSTEM

Create a fumes exhaust system based on the "Type" of appliance. The "Type" is stated on the appliance dataplate.

#### " A1 " TYPE APPLIANCE

Position the "A1" type appliance below an extractor hood to ensure smoke and fumes generated by cooking are removed.

#### " B21 " TYPE APPLIANCE

Position the "B21" type appliance below an extractor hood.

#### " B11 " TYPE APPLIANCE

Fit the "B11" type appliance with a suitable flue, available from the appliance manufacturer. Follow the assembly instructions provided with the flue.

Connect the flue to a 150/155 mm diameter hose, heat resistant to 300°C.

Vent to the outside or into an efficient flue. The hose length must not exceed 3 metres.

## 6. CONNECTIONS

The position and dimensions of connections are given in the installation diagram at the end of this manual.

### CONNECTION TO THE GAS SUPPLY

- Check that the appliance is designed to operate with the type of gas supply present on site. Check the information given on the decals on the packing

and appliance.

- Convert the appliance to the local gas type, if necessary. Follow the instructions at the next paragraph "Conversion to a different type of gas".
- On top appliances a rear connection is also available. Remove the plug present and screw it tightly onto the front connector.
- A rapid-action gas shut-off valve must be fitted upstream of the appliance in an easily accessible position.
- Do not use connection pipes having a diameter smaller than that of the appliance's gas connector.
- Once the appliance has been installed, check for gas leaks at the connection points.

### ELECTRICAL CONNECTIONS

Check if the appliance is designed to operate at the voltage and frequency of the power supply present on site. Check the details given on the appliance dataplate and plaque near the terminal board.

Install upstream of the equipment in an easily accessible place, an all-pole disconnecting device with a contact gap of allowing full disconnection under the conditions of overvoltage category III.

A flexible rubber cable with insulation specifications not lower than type H05 RN-F must be used for connection.

Connect the power supply cable to the terminal board as shown in the wiring diagram supplied with the appliance.

Secure the power supply cable with the cable clamp.

Protect the power supply cable on the outside of the appliance with a rigid plastic or metal pipe.

If the power supply cable is damaged, it must be replaced by the manufacturer or his service centre or by a person with similar qualifications to prevent any risk.



**THE SYMBOL " HIGH VOLTAGE " IS PLACED ON A PANEL THAT GIVES ACCESS TO A PART WITH HIGH VOLTAGE.**

### PROTECTIVE EARTH AND EARTH BONDING CONNECTIONS

- Connect the appliance to an efficient ground circuit. Connect the earth conductor to the terminal with the symbol  $\oplus$  next to the main terminal board.
- Connect the metal structure of the appliance to the equipotential node. Connect the conductor to the terminal with the symbol  $\nabla$  on the outside part of the bottom.

## CONNECTION TO THE WATER SUPPLY

- The appliance must be connected to a potable water supply. The water inlet pressure must be between 150 kPa and 300 kPa. Use a pressure reducer if the inlet pressure is above the maximum permitted level.
- Install a mechanical filter and a shut-off valve upstream of the appliance in an easily accessible point.
- Make sure the water circuit is free of ferrous particles before connecting the filter and the appliance.
- Seal any unused connectors with a plug.
- Once the appliance has been installed, check for gas leaks at the connection points.

## CONNECTION TO THE WATER DRAIN

The water drainage system must be made using materials resistant to temperatures of 100 °C. The bottom of the appliance must not be subjected to steam produced by drainage of hot water. Install a siphoned floor drain with grating below the water drain cock of Boiling pans and in front of Bratt pans.



## 7. CONVERSION TO ANOTHER TYPE OF GAS

Table Tab1 specifies:

which gas can be used for the appliance.  
the nozzles and settings for each gas that can be used.

For nozzles, the number indicated in table TAB1 is also stamped on the body of nozzles.

To convert the appliance to the local gas type, follow the instructions given in TAB1 and carry out the steps below:

- Replace the main burner nozzle (UM).
- Adjust the main burner's air regulator to distance A.
- Replace the pilot burner nozzle (UP).
- Adjust the pilot burner air flow (if necessary).
- Replace the gas valve minimum nozzle (Um).
- Affix the adhesive tab indicating the new type of gas used.
- The nozzles and adhesive tabs are supplied with the appliance.

## REPLACING THE NOZZLE AND THE MAIN BURNER PRIMARY AIR REGULATION

- Remove the control panel.
- Remove nozzle UM and replace it with the one indicated in table TAB1.
- Retighten nozzle UM.
- Slacken screw V and position the air regulator at distance A as indicated in table TAB1.
- Retighten screw V fully.
- Reassemble all parts. For assembly, proceed in reverse order.

## REPLACING THE MINIMUM ADJUSTMENT SCREW

- Remove the control panel.
- Remove nozzle UM and replace it with the one indicated in table TAB1.
- Retighten nozzle UM.
- Reassemble all parts. For assembly, proceed in reverse order.

## REPLACING THE PILOT BURNER NOZZLE

- Remove the control panel.
- Undo connector R.
- Remove nozzle UP and replace it with the one indicated in table TAB1.
- Retighten connector R. Reassemble all parts.
- Following, in reverse order, the sequence used for their removal.

## 8. COMMISSIONING

Following installation, conversion to a different type of gas or any maintenance operations, check appliance operation. In the event of any malfunction, consult the next Paragraph " Troubleshooting " .

## GAS APPLIANCES

Switch on the appliance as directed in the instructions and reminders for use given in Chapter " INSTRUCTIONS FOR USE " and check:  
the gas supply pressure (see next Paragraph).  
the correct ignition of the burners and the effectiveness of the fumes removal system.

## CHECKING THE GAS SUPPLY PRESSURE

To measure the gas supply pressure use a manometer with a minimum definition of 0,1 mbar. Remove the control panel.

Remove the screw from on pressure test point PP and connect the manometer to the test point.

Make the measurement with the appliance in operation.



**IMPORTANT! IF THE GAS SUPPLY PRESSURE IS NOT WITHIN THE LIMITS (MIN. - MAX) INDICATED IN TABLE TAB2, CEASE OPERATION OF THE APPLIANCE AND CONTACT THE GAS UTILITY COMPANY.**

Disconnect the manometer and retighten the retaining screw on the pressure connection.

## ELECTRIC EQUIPMENT

Switch on the appliance as directed in the instructions and reminders for use given in Chapter " INSTRUCTIONS FOR USE " and check:

the current values of each phase.

the correct operation of the heating elements.

## III. INSTRUCTIONS FOR USE

### 9. REMINDERS FOR THE USER



**READ THIS MANUAL CAREFULLY. IT PROVIDES IMPORTANT INFORMATION FOR SAFE INSTALLATION, USE AND MAINTENANCE OF THE APPLIANCE. THE MANUFACTURER WILL NOT BE LIABLE FOR ANY DAMAGE OR INJURY RESULTING FROM FAILURE TO OBSERVING THE FOLLOWING RULES.**



For after-sales service, contact technical assistance centres authorized by the manufacturer and demand the use of original spare parts.

Have the appliance serviced at least twice a year. The manufacturer recommends taking out a service contract.

The appliance is designed for professional use and must be operated by trained personnel.

The appliance is to be used for cooking food as specified in the prescriptions for use. Any other use is considered to be improper.

Do not allow the appliance to operate empty for prolonged periods. Only pre-heat the oven just before use.

Do not leave the appliance unattended while in operation.

In the event of an appliance fault or malfunction, shut the gas shut-off valve and/or switch the appliance off at the main switch installed upline.

Clean the appliance following the instructions given in Chapter " INSTRUCTIONS FOR CLEANING".



**DO NOT STORE " AMMABLE MATERIALS IN CLOSE PROXIMITY TO THE APPLIANCE. FIRE HAZARD.**

Do not obstruct any air vents or drains present on the appliance.

Do not tamper with appliance components.

Keep this manual in a safe place, known to all users, so that it can be consulted throughout the working life of the appliance.

Installation and appliance maintenance must be carried out by qualified technicians authorized by the manufacturer, in compliance with current safety standards and the instructions in this manual.

Appliance maintenance and conversion to a different type of gas must be carried out by qualified technicians authorized by the manufacturer, in compliance with current safety standards and the instructions in this manual.

### 10. POSITIONING THE CAST IRON GRILLES

The cooking grille is reversible, sloping for meat and horizontal for fish and vegetables.

### 11. USING THE GAS GRILL

The appliance is designed for cooking foods placed on the grilles provided.

The grill must not be used to heat pans or saucepans.

## BURNER IGNITION AND EXTINGUISHING



The gas tap control knob has the following positions:

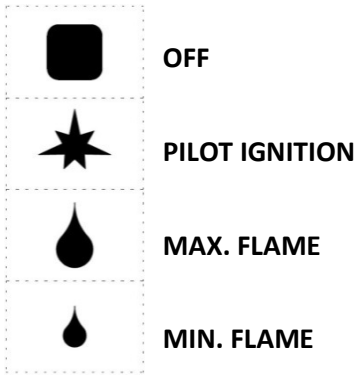

#### PILOT IGNITION

- Press and turn knob to “pilot on”.
- Press the knob down fully and light the pilot using the piezoelectric igniter.
- Hold the knob down for about 20 seconds before releasing it. If the pilot flame goes out, repeat the operation.

#### MAIN BURNER IGNITION

- To light the main burner, turn the knob from “pilot on” to “max. flame”.
- Next, depending on cooking requirements, turn the knob to any position between " max. flame " and " min. flame " .

#### TURNING OFF

- To switch the main burner off, turn the knob to position " pilot on " .
- To switch off the pilot flame, press and turn the knob to position " Off " .

#### USING THE GREASE COLLECTION TRAY

- Pour 2-3 cm of water into the grease collection tray to facilitate cleaning and obtain optimum cooking results.

#### GREASE COLLECTION TRAY

Any grease from cooking which drips into the grill and passes through the brazier is collected in the grease collection tray. Periodically empty and clean this tray.

## 12. USING THE ELECTRIC GRILL

The appliance is designed for cooking foods placed on the grilles provided.

The grill must not be used to heat pans or saucepans.

#### SWITCHING ON AND OFF

The thermostat control knob has the following positions:

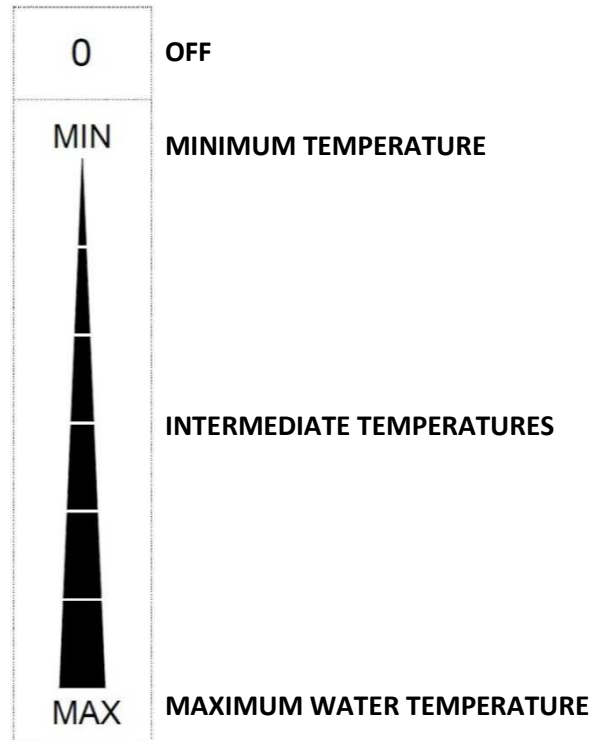

#### SWITCHING ON

- Turn the thermostat knob to the chosen temperature setting for cooking.
- The yellow indicator light switches on.
- The yellow indicator light switches off when the oven reaches the set temperature.

#### TURNING OFF

Turn the thermostat knob to position " 0 " .  
The yellow indicator light switches off.

#### USING THE GREASE COLLECTION TRAY

Pour 2-3 cm of water into the grease collection tray to facilitate cleaning and obtain optimum cooking results.

#### GREASE COLLECTION TRAY

Any grease from cooking which drips into the grill and passes through the brazier is collected in the grease collection tray. Periodically empty and clean this tray.

### 13. USING THE GAS LAVA STONE GRILL

The appliance is designed for cooking foods placed on the grilles provided.

The grill must not be used to heat pans or saucepans.

#### LOADING THE LAVA STONE

The appliances come complete with 2 packs of lava stone for each brazier (cooking zone).

Each pack weighs 4 kg.

The lava stones have a min. diameter of 25mm, a max. diameter of 30mm and a max. length of 50mm, with a +/- 5% tolerance.

Distribute the contents of one pack evenly between the braziers. Do not under any circumstances use more lava stone than recommended.

The second pack must only be used to top up the lava stone originally loaded as the latter is gradually consumed.

#### GREASE COLLECTION TRAY

Any grease from cooking which drips into the grill and passes through the brazier is collected in the grease collection tray. Periodically empty and clean this tray.

#### BURNER IGNITION AND EXTINCTION

The gas tap control knob has the following positions:

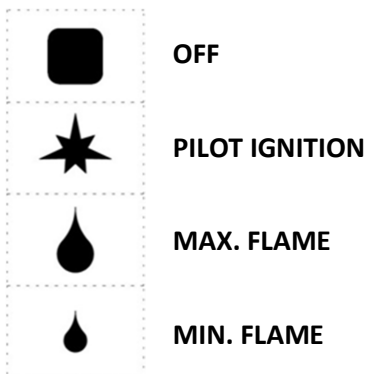

PILOT IGNITION

- Press and turn knob to "pilot on".
- Press the knob down fully and light the pilot using the piezoelectric igniter.
- Hold the knob down for about 20 seconds before releasing it. If the pilot flame goes out, repeat the operation.

#### MAIN BURNER IGNITION

- To light the main burner, turn the knob from "pilot on" to "max. flame".
- Next, depending on cooking requirements, turn the knob to any position between " max. flame " and " min. flame " .

#### TURNING OFF

- To switch the main burner off, turn the knob to position " pilot on " .
- To switch off the pilot flame, press and turn the knob to position " Off " .

### 14. PROLONGED DISUSE

Before any prolonged disuse of the appliance, proceed as follows:

- Clean the appliance thoroughly.
- Rub stainless steel surfaces with a cloth soaked in vaseline oil to create a protective film.
- Close cocks or main switches ahead of the appliances.

Following prolonged disuse, proceed as follows:

- Inspect the appliance thoroughly before using it again.
- Allow electric appliances to operate at the lowest temperature for at least 60 minutes.

## IV. INSTRUCTIONS FOR CLEANING

### 15. REMINDERS FOR CLEANING



**READ THIS MANUAL CAREFULLY. IT PROVIDES IMPORTANT INFORMATION FOR SAFE INSTALLATION, USE AND MAINTENANCE OF THE APPLIANCE.**



**THE MANUFACTURER WILL NOT BE LIABLE FOR ANY DAMAGE OR INJURY RESULTING FROM FAILURE TO OBSERVING THE FOLLOWING RULES. DISCONNECT THE APPLIANCE ELECTRIC SUPPLY, IF PRESENT, BEFORE CARRYING OUT ANY OPERATION.**



- Clean the satin finish stainless steel exterior surfaces, the cooking wells and the surface of the hotplates every day.
- At least twice a year, have an authorized technician clean the internal parts of the appliance.
- Do not use corrosive products to clean the floor beneath the appliance.
- Do not use direct or high pressure water jets to clean the appliance.

### SATIN FINISH STAINLESS STEEL SURFACES

- Clean the surfaces with a cloth or sponge using water and proprietary non-abrasive detergents. Follow the direction of the satin finish lines. Rinse repeatedly and dry thoroughly.
- Do not use pan scourers or other iron items.
- Do not use chemical products containing chlorine.
- Do not use sharp objects which might scratch and damage the surfaces.

### COLLECTION TRAYS

- Clean the surface, removing grease, oil, food residue etc.. .

### GAS GRILL

Cleanind the burner and brazier grille



**IMPORTANT: BEFORE CARRYING OUT ANY CLEANING OPERATIONS, MAKE SURE THE GRILLES ARE COLD.**

- Lift up and remove the cooking grille and the splashguard.
- Remove the tiles.
- Proceed to clean the burner around the fl ame zone and along the flame protector apertures, removing all traces of dust and burnt-on residue whilst taking care not to enlarge the flame apertures.
- Using a scraper, clean the fi ns of the combustion chamber that convey cooking juices into the

collection drawer and then wipe with a damp cloth.

- Take care not to damage the pilot ignition unit.
- Refit the tile, taking care to insert the front pins in their seats.

### GAS LAVA STONE GRILL



**IMPORTANT: BEFORE CARRYING OUT ANY CLEANING OPERATIONS, MAKE SURE THE GRILLES ARE COLD.**

- Lift up and remove the cooking grille and the brazier containing the lava stone.
- Proceed to clean the burner around the fl ame zone and along the flame protector apertures, removing all traces of dust and burnt-on residue whilst taking care not to enlarge the flame apertures.

### ELECTRIC GRILL



**IMPORTANT: BEFORE CARRYING OUT ANY CLEANING OPERATIONS, MAKE SURE THE HEATING ELEMENTS ARE COLD.**

- Disconnect the appliance from the power supply.
- Remove the grille and splashguard.
- Clean the inside of the grill with a scraper.



**IMPORTANT: DO NOT CLEAN THE ELEMENTS AND DO NOT USE WATER INSIDE THE GRILL SINCE THE APPLIANCE CONTAINS ELECTRICAL COMPONENTS.**

## v. INSTRUCTIONS FOR MAINTENANCE

### 16. REMINDERS FOR THE MAINTENANCE TECHNICIAN



**THE MANUFACTURER WILL NOT BE LIABLE FOR ANY DAMAGE OR INJURY RESULTING FROM FAILURE TO OBSERVING THE FOLLOWING RULES.**

Identify the specific appliance model. The model number is detailed on the packing and on the

appliance dataplate.

The appliance must be installed in a well-ventilated room.

Do not obstruct any air vents or drains present on the appliance.

Do not tamper with appliance components.

Appliance maintenance and conversion to a different type of gas must be carried out by qualified technicians authorized by the manufacturer, in compliance with current safety standards and the instructions in this manual.

## 17. CONVERSION TO ANOTHER TYPE OF GAS

See Chapter “Instructions for installation”.

## 18. COMMISSIONING

See Chapter “Instructions for installation”.

## 19. TROUBLESHOOTING

### GAS GRILL

#### THE PILOT BURNER DOES NOT LIGHT.

Possible causes:

- Insufficient gas supply pressure.
- Blocked tubing or nozzle.
- Defective gas tap or valve.
- Igniter defective or not properly connected.
- Igniter or igniter wire defective.

#### PILOT BURNER GOES OUT DURING USE.

Possible causes:

- Insufficient gas supply pressure.
- Defective gas tap or valve.
- Defective thermocouple or insufficient heating.
- Thermocouple incorrectly connected to gas tap or valve.
- Knob of gas tap or valve not pressed sufficiently.

#### THE MAIN BURNER DOES NOT LIGHT (EVEN

#### THOUGH PILOT IS LIT).

Possible causes:

- Defective burner (gas outlet holes clogged).

### ELECTRIC GRILL

#### THE APPLIANCE DOES NOT HEAT.

Possible causes:

- Temperature thermostat defective.
- Heating elements defective.

#### HEATING CANNOT BE ADJUSTED.

Possible causes:

- Temperature thermostat defective.

### GAS LAVA STONE GRILL

#### THE PILOT BURNER DOES NOT LIGHT.

Possible causes:

- Insufficient gas supply pressure.
- Blocked tubing or nozzle.
- Defective gas tap or valve.
- Igniter defective or not properly connected.
- Igniter or igniter wire defective.

#### PILOT BURNER GOES OUT DURING USE.

Possible causes:

- Insufficient gas supply pressure.
- Defective gas tap or valve.
- Defective thermocouple or insufficient heating.
- Thermocouple incorrectly connected to gas tap or valve.
- Knob of gas tap or valve not pressed sufficiently.

#### THE MAIN BURNER DOES NOT LIGHT (EVEN THOUGH PILOT IS LIT).

Possible causes:

- Defective burner (gas outlet holes clogged).

## 20. REPLACING COMPONENTS

### REMINDERS FOR REPLACING COMPONENTS



**SHUT THE GAS SHUT-OFF VALVE AND/OR SWITCH THE APPLIANCE OFF AT THE MAIN SWITCH INSTALLED UPSTREAM.**



**DISCONNECT THE APPLIANCE ELECTRIC SUPPLY, IF PRESENT, BEFORE CARRYING OUT ANY OPERATION.**



**AFTER REPLACING A GAS SYSTEM COMPONENT, CHECK FOR GAS LEAKS AT CONNECTION POINTS.**



**AFTER REPLACING AN ELECTRICAL SYSTEM COMPONENT, CHECK IT IS CORRECTLY WIRED.**

## **GAS GRILL**

### **REPLACING THE GAS TAP.**

- Remove the control knob.
- Remove the bottom front panel.
- Remove and replace the component.
- Reassemble all parts. For assembly, proceed in reverse order.

### **REPLACING THE BURNER, THE PILOT BURNER AND THE THERMOCOUPLE.**

- Remove the grease collection drawer.
- Remove the control panel.
- Remove and replace the component.
- Reassemble all parts. For assembly, proceed in reverse order.

### **REPLACING THE MAIN BURNER.**

- Remove the grease collection drawer.
- Remove the control knob.
- Remove the bottom front panel.
- Remove the control panel.
- Remove the splashguard, the grilles, the tiles, the front tile support and the burner guard.
- Remove and replace the component.
- Reassemble all parts. For assembly, proceed in reverse order.

## **ELECTRIC GRILL**

### **REPLACING THE KNOB AND INDICATOR LIGHT**

- Remove the grease collection drawer.

- Remove the control knob.
- Remove the bottom front panel.
- Remove and replace the component.
- Reassemble all parts. For assembly, proceed in reverse order.

### **REPLACING THE ELEMENT.**

- Remove the grease collection drawer.
- Remove the control panel.
- Remove the splashguard and the grille.
- Remove the box and the cover of the element terminals by unscrewing the self-tapping screws from the top of the appliance.
- Remove the component from above and replace it.
- Reassemble all parts. For assembly, proceed in reverse order.

### **REPLACING THE WORKING THERMOSTAT.**

- Remove the grease collection drawer.
- Remove the control knob.
- Remove the bottom control panel.
- Remove and replace the component.
- Reassemble all parts. For assembly, proceed in reverse order.

## **GAS LAVA STONE GRILL**

### **REPLACING THE GAS TAP.**

- Remove the control panel.
- Remove and replace the component.
- Reassemble all parts. For assembly, proceed in reverse order.

### **REPLACING THE PILOT BURNER AND THERMOCOUPLE.**

- Remove the control panel.
- Remove the grilles, lava stone and support brazier.
- Remove and replace the component.
- Reassemble all parts. For assembly, proceed in reverse order.

### **REPLACING THE MAIN BURNER.**

- Remove the control panel.
- Remove the grilles, lava stone and support brazier.
- Remove and replace the component.

- Reassemble all parts. For assembly, proceed in reverse order.

## 21. CLEANING THE INTERIOR

Check the condition of the inside of the appliance.

Remove any built-up dirt.

Check and clean the fumes exhaust system.

## 22. MAIN COMPONENTS

### **GAS GRILL**

- Gas Cock
- Main Burner
- Pilot burner
- Thermocouple
- Igniter
- Piezoelectric ignition

### **ELECTRIC GRILL**

- Working thermostat
- Heating element
- Indicator light

### **GAS LAVA STONE GRILL**

- Main Burner
- Pilot burner
- Thermocouple
- Igniter
- Piezoelectric ignition
- Gas Cock
- Brazier
- Volcanic lava stone

**VI. SCHEMI DI INSTALLAZIONE – INSTALLATIONS PLAN - INSTALLATION DIAGRAM – SCHEMA D’INSTALLATION – ESQUEMA DE INSTALACION - INSTALLATIESCHEMA'S**

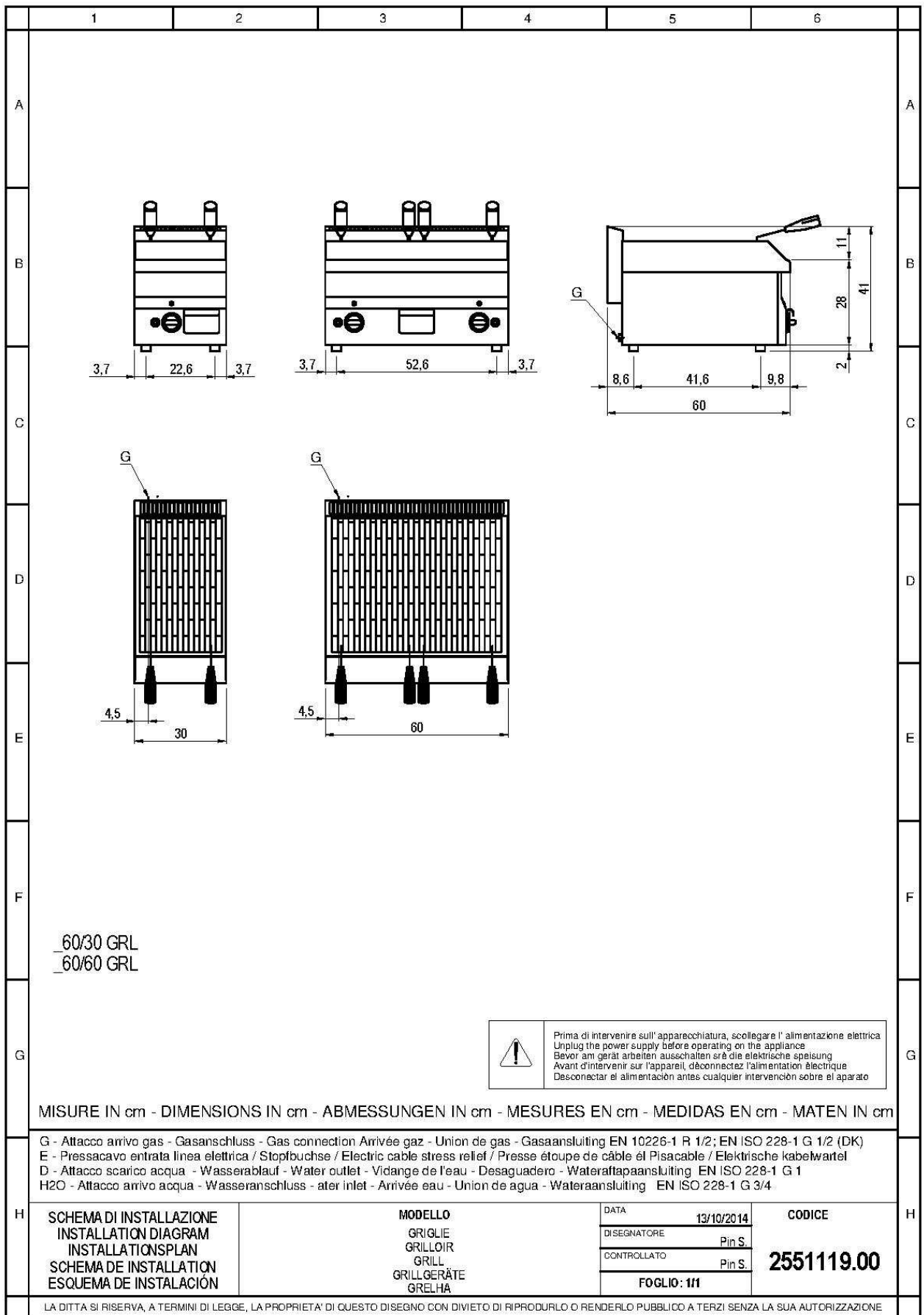

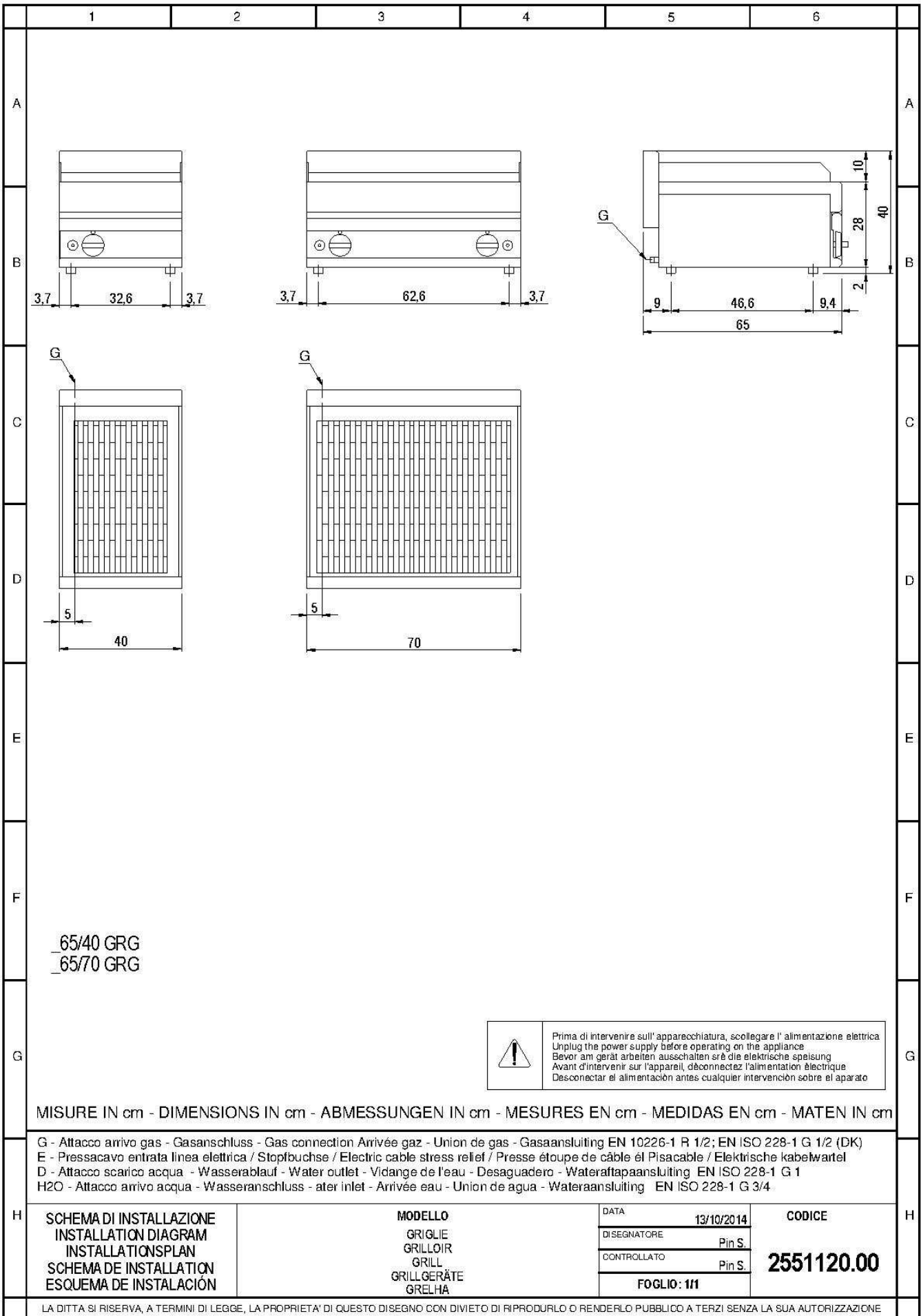

65/40 GRG  
65/70 GRG

 Prima di intervenire sull'apparecchiatura, scollegare l'alimentazione elettrica  
Unplug the power supply before operating on the appliance  
Bevor am gerät arbeiten ausschalten srê die elektrische speisung  
Avant d'intervenir sur l'appareil, déconnectez l'alimentation électrique  
Desconectar el alimentación antes cualquier intervencion sobre el aparato

MISURE IN cm - DIMENSIONS IN cm - ABMESSUNGEN IN cm - MESURES EN cm - MEDIDAS EN cm - MATEN IN cm

G - Attacco arrivo gas - Gasanschluss - Gas connection Arrivée gaz - Union de gas - Gasaansluiting EN 10226-1 R 1/2; EN ISO 228-1 G 1/2 (DK)  
E - Pressacavo entrata linea elettrica / Stopbuchse / Electric cable stress relief / Presse étoupe de câble él Pisacable / Elektrische kabelwartel  
D - Attacco scarico acqua - Wasserablauf - Water outlet - Vidange de l'eau - Desaguadero - Wateraftapaansluiting EN ISO 228-1 G 1  
H2O - Attacco arrivo acqua - Wasseranschluss - ater inlet - Arrivée eau - Union de agua - Wateraansluiting EN ISO 228-1 G 3/4

<b>H</b> SCHEMA DI INSTALLAZIONE INSTALLATION DIAGRAM INSTALLATIONSPLAN SCHEMA DE INSTALLATION ESQUEMA DE INSTALACIÓN	<b>MODELLO</b> GRIGLIE GRILLOIR GRILL GRILLGERÄTE GRELHA	DATA	13/10/2014	<b>CODICE</b>  <b>2551120.00</b>	<b>H</b>
		DI SEGNA TORE	Pin S.		
		CONTROLLATO	Pin S.		
		<b>FOGLIO: 111</b>			

LA DITTA SI RISERVA, A TERMINI DI LEGGE, LA PROPRIETA' DI QUESTO DISEGNO CON DIVIETO DI RIPRODURLO O RENDERLO PUBBLICO A TERZI SENZA LA SUA AUTORIZZAZIONE



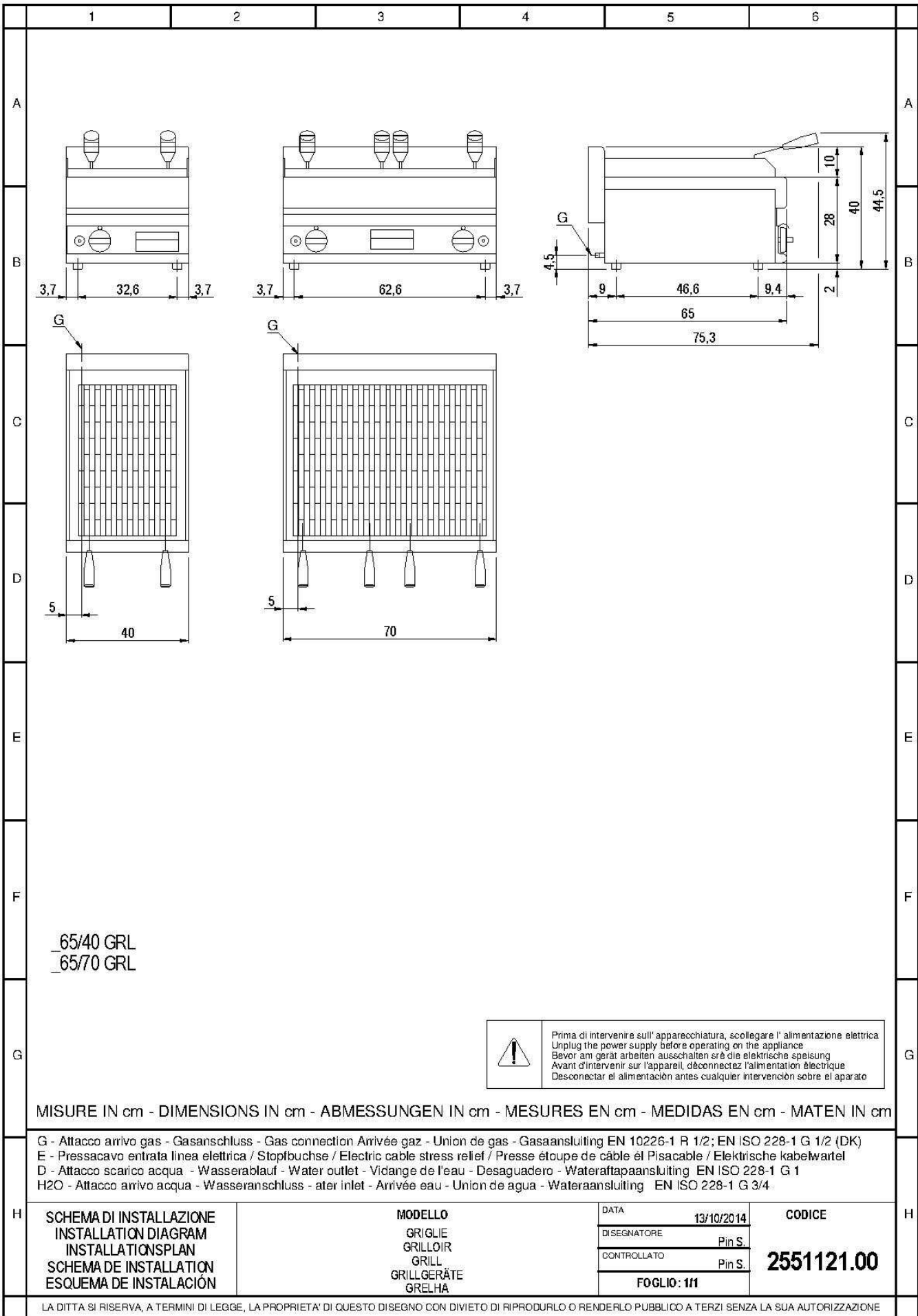

65/40 GRL  
65/70 GRL

 Prima di intervenire sull'apparecchiatura, scollegare l'alimentazione elettrica  
Unplug the power supply before operating on the appliance  
Bevor am gerät arbeiten ausschalten srê die elektrische speisung  
Avant d'intervenir sur l'appareil, dëconnectez l'alimentation électrique  
Desconectar el alimentacion antes cualquier intervencion sobre el aparato

MISURE IN cm - DIMENSIONS IN cm - ABMESSUNGEN IN cm - MESURES EN cm - MEDIDAS EN cm - MATEN IN cm

G - Attacco arrivo gas - Gasanschluss - Gas connection Arrivée gaz - Union de gas - Gasaansluiting EN 10226-1 R 1/2; EN ISO 228-1 G 1/2 (DK)  
E - Pressacavo entrata linea elettrica / Stopfbuchse / Electric cable stress relief / Presse étoupe de câble él Pisacable / Elektrische kabelwartel  
D - Attacco scarico acqua - Wasserablauf - Water outlet - Vidange de l'eau - Desaguadero - Wateraftapaansluiting EN ISO 228-1 G 1  
H2O - Attacco arrivo acqua - Wasseranschluss - ater inlet - Arrivée eau - Union de agua - Wateraansluiting EN ISO 228-1 G 3/4

SCHEMA DI INSTALLAZIONE  
INSTALLATION DIAGRAM  
INSTALLATIONSPLAN  
SCHEMA DE INSTALLATION  
ESQUEMA DE INSTALACIÓN

MODELLO  
GRILLIE  
GRILLOIR  
GRILL  
GRILLGERÄTE  
GRELHA

DATA	13/10/2014
DISEGNATORE	Pin S.
CONTROLLATO	Pin S.
FOGLIO: 111	

CODICE  
**2551121.00**

LA DITTA SI RISERVA, A TERMINI DI LEGGE, LA PROPRIETÀ DI QUESTO DISEGNO CON DIVIETO DI RIPRODURLO O RENDERLO PUBBLICO A TERZI SENZA LA SUA AUTORIZZAZIONE

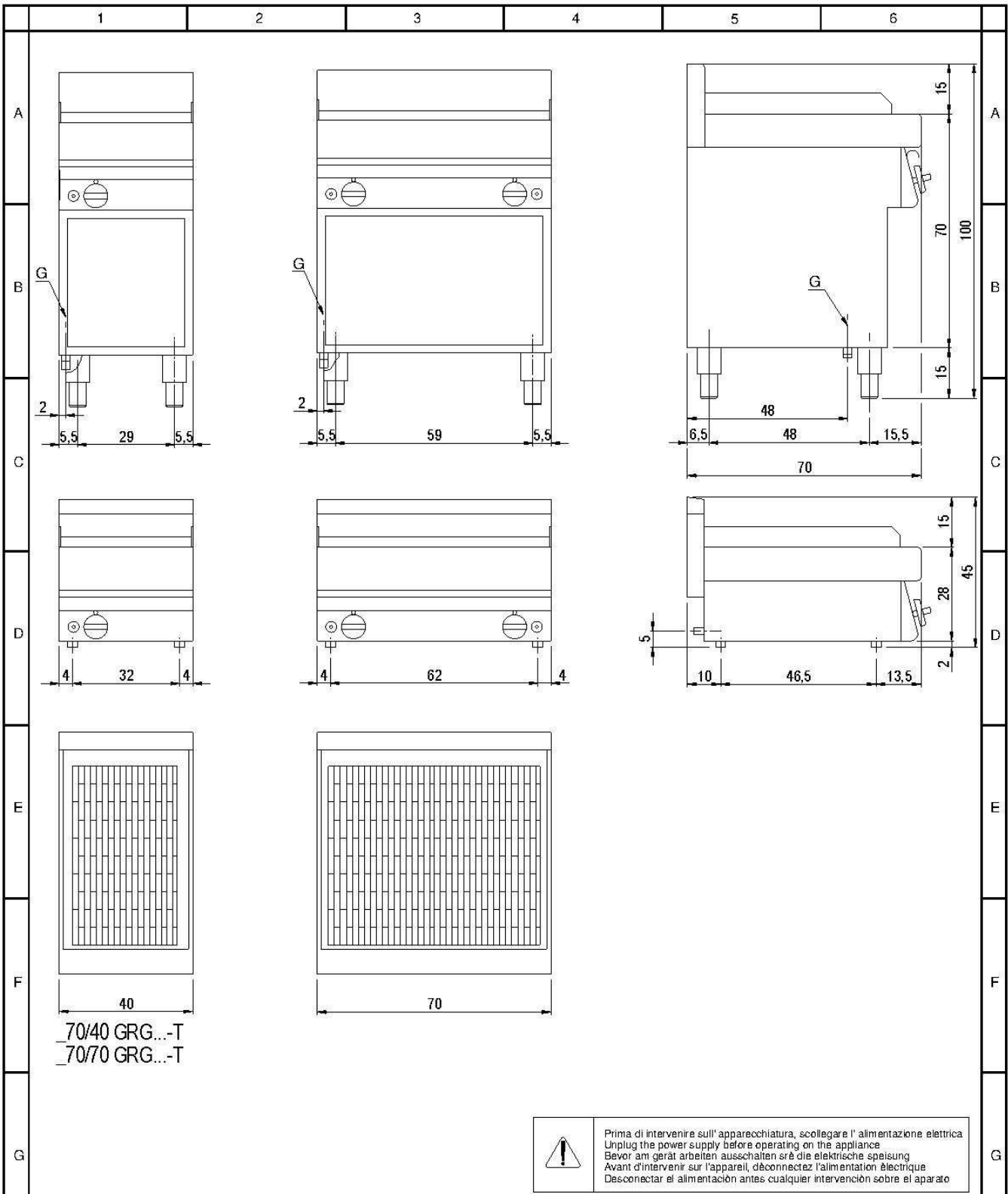

70/40 GRG...-T  
70/70 GRG...-T

 Prima di intervenire sull'apparecchiatura, scollegare l'alimentazione elettrica  
Unplug the power supply before operating on the appliance  
Bevor am Gerät arbeiten ausschalten srê die elektrische speisung  
Avant d'intervenir sur l'appareil, déconnectez l'alimentation électrique  
Desconectar el alimentación antes cualquier intervencion sobre el aparato

MISURE IN cm - DIMENSIONS IN cm - ABMESSUNGEN IN cm - MESURES EN cm - MEDIDAS EN cm - MATEN IN cm

G - Attacco arrivo gas - Gasanschluss - Gas connection Arrivée gaz - Union de gas - Gasaansluiting EN 10226-1 R 1/2; EN ISO 228-1 G 1/2 (DK)  
E - Pressacavo entrata linea elettrica / Stopbuchse / Electric cable stress relief / Presse étoupe de câble él Pisacable / Elektrische kabelwartel  
D - Attacco scarico acqua - Wasserablauf - Water outlet - Vidange de l'eau - Desaguadero - Wateraftapaansluiting EN ISO 228-1 G 1  
H2O - Attacco arrivo acqua - Wasseranschluss - ater inlet - Arrivée eau - Union de agua - Wateraansluiting EN ISO 228-1 G 3/4

H	SCHEMA DI INSTALLAZIONE INSTALLATION DIAGRAM INSTALLATIONSPLAN SCHEMA DE INSTALLATION ESQUEMA DE INSTALACIÓN	MODELLO GRIGLIE GRILLOIR GRILL GRILLGERÄTE GRELHA	DATA	13/10/2014	CODICE
			DI SEGNA TORE	Pin S.	
			CONTROLLATO	Pin S.	<b>2551122.00</b>
			FOGLIO: 111		

LA DITTA SI SERVA, A TERMINI DI LEGGE, LA PROPRIETA' DI QUESTO DISEGNO CON DIVIETO DI RIPRODURLO O RENDERLO PUBBLICO A TERZI SENZA LA SUA AUTORIZZAZIONE

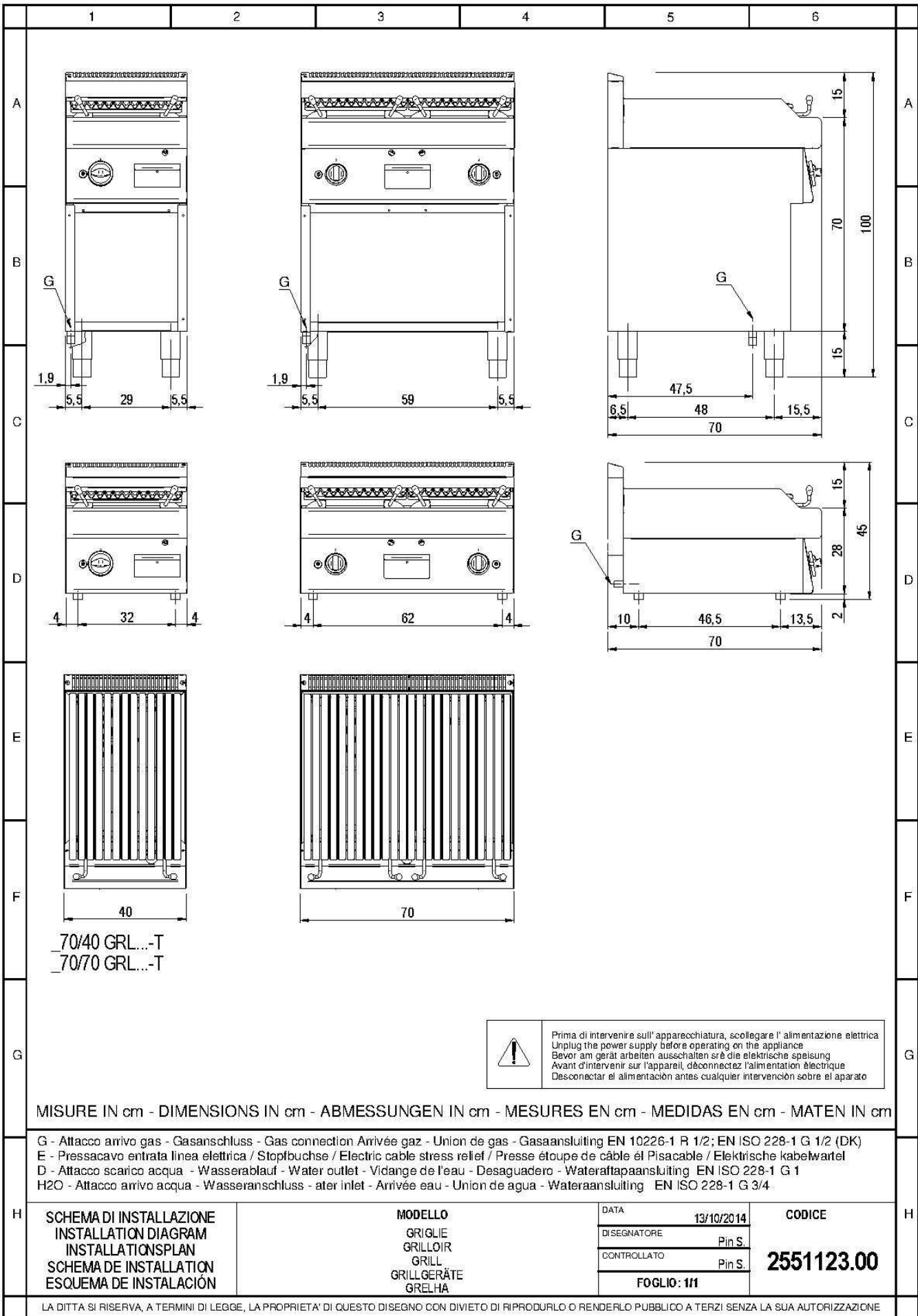

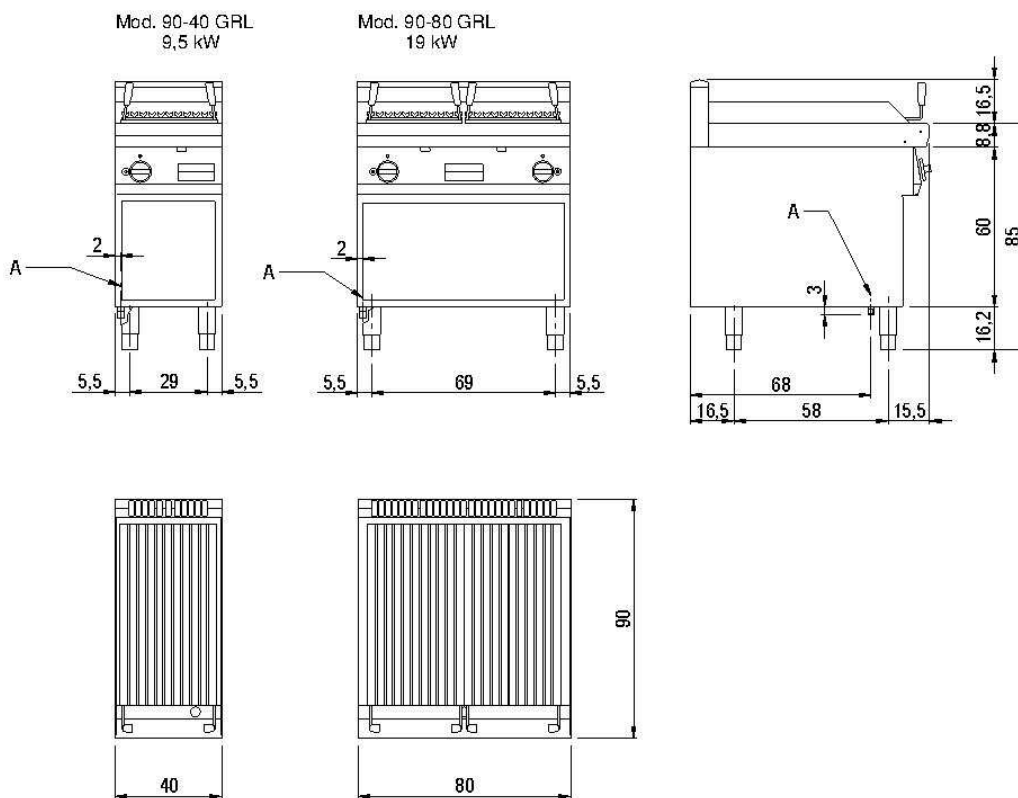

A= Attacco gas / Arrivee gaz / Gasanschluss / Gas inlet  
 EN 10226-1 R 1/2  
 EN ISO228-1 G 1/2 (DK)

Tipo di apparecchi "A1" - Appareilles du type "A1" - Aparatos de tipo "A1"  
 Geräte-Typ "A1" - Type of appliances "A1"



Prima di intervenire sull'apparecchiatura, scollegare l'alimentazione elettrica - Unplug the power supply before operating on the appliance  
 Bevor am Gerät arbeiten ausschalten an die elektrische speisung  
 Avant d'intervenir sur l'appareil, déconnectez l'alimentation électrique - Desconectar el alimentación antes cualquier intervención sobre el aparato

SCHEMA DI INSTALLAZIONE  
 SCHEMA DE INSTALLATION  
 INSTALLATION DIAGRAM  
 INSTALLATIONSPLAN  
 ESQUEMA DE INSTALACIÓN

MODELLO

90-40 GRL  
 90-80 GRL

data: 25/09/2012

nome: Pasquet

ultima mod.: /

FOGLIO: 1/1

CODICE

255.300.02

LA DITTA SI RISERVA, A TERMINI DI LEGGE, LA PROPRIETA' DI QUESTO DISEGNO CON DIVIETO DI RIPRODURLO O RENDERLO PUBBLICO A TERZI SENZA LA SUA AUTORIZZAZIONE

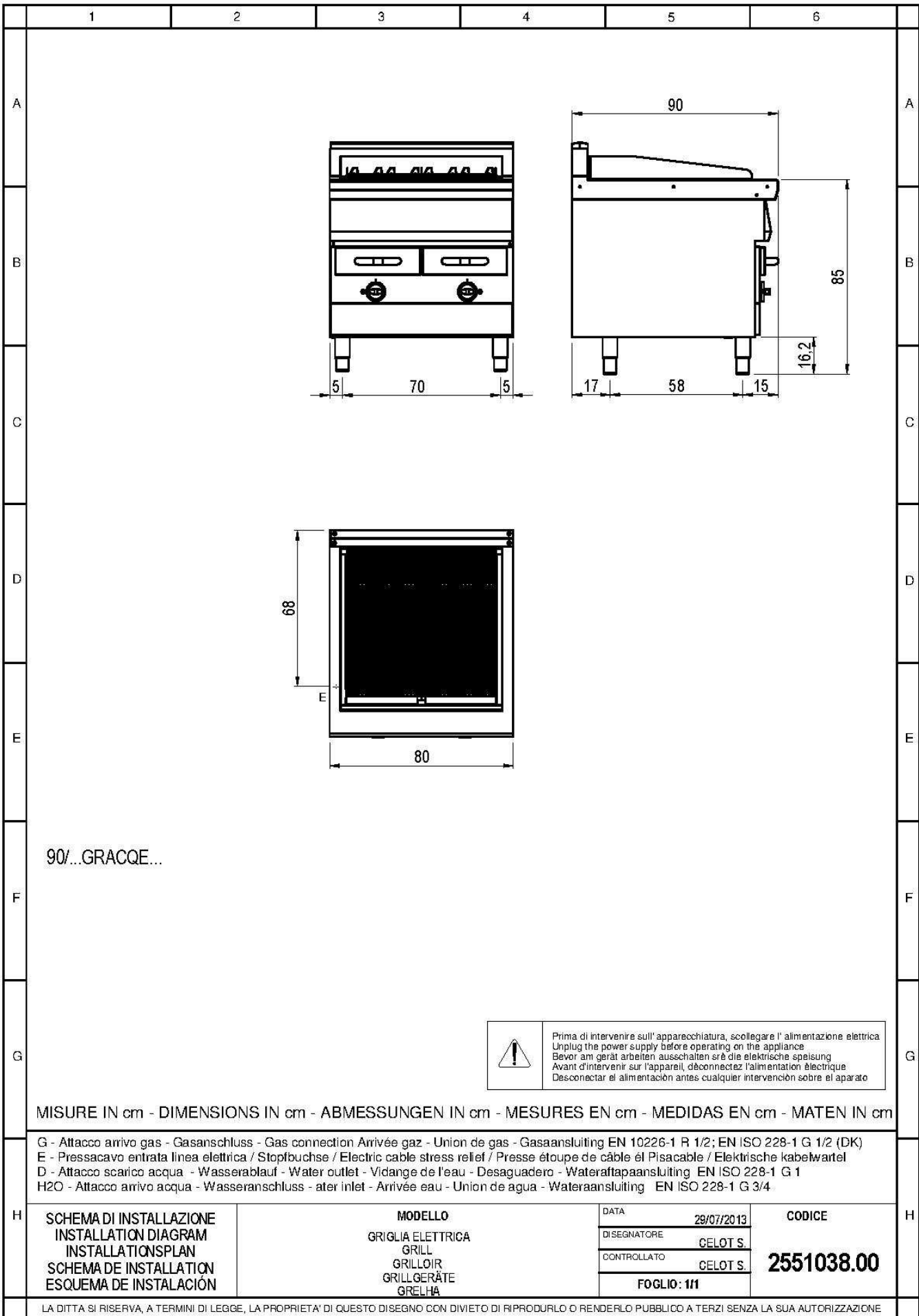

90/...GRACQE...

 Prima di intervenire sull'apparecchiatura, scollegare l'alimentazione elettrica  
 Unplug the power supply before operating on the appliance  
 Bevor am gerät arbeiten ausschalten srê die elektrische speisung  
 Avant d'intervenir sur l'appareil, dëconnectez l'alimentation électrique  
 Desconectar el alimentacion antes cualquier intervencion sobre el aparato

MISURE IN cm - DIMENSIONS IN cm - ABMESSUNGEN IN cm - MESURES EN cm - MEDIDAS EN cm - MATEN IN cm

G - Attacco arrivo gas - Gasanschluss - Gas connection Arrivée gaz - Union de gas - Gasaansluiting EN 10226-1 R 1/2; EN ISO 228-1 G 1/2 (DK)  
 E - Pressacavo entrata linea elettrica / Stopfbuchse / Electric cable stress relief / Presse étoupe de câble él Pisacable / Elektrische kabelwartel  
 D - Attacco scarico acqua - Wasserablauf - Water outlet - Vidange de l'eau - Desaguadero - Wateraftapaansluiting EN ISO 228-1 G 1  
 H2O - Attacco arrivo acqua - Wasseranschluss - ater inlet - Arrivée eau - Union de agua - Wateraansluiting EN ISO 228-1 G 3/4

<b>H</b> SCHEMA DI INSTALLAZIONE INSTALLATION DIAGRAM INSTALLATIONSPLAN SCHEMA DE INSTALLATION ESQUEMA DE INSTALACIÓN	<b>MODELLO</b>	DATA	29/07/2013	<b>CODICE</b>
	GRIGLIA ELETTRICA GRILL GRILLOIR GRILLGERÄTE GRELHA	DI SEGNA TORE	CELOT S.	
		CONTROLLATO	CELOT S.	
		<b>FOGLIO: 111</b>		

LA DITTA SI RISERVA, A TERMINI DI LEGGE, LA PROPRIETA' DI QUESTO DISEGNO CON DIVIETO DI RIPRODURLO O RENDERLO PUBBLICO A TERZI SENZA LA SUA AUTORIZZAZIONE

VII. FIGURE – ABB. – FIG. FIGURE-FIG.-IMAGE-ABB.-CIFRAS-AFBEELDINGEN

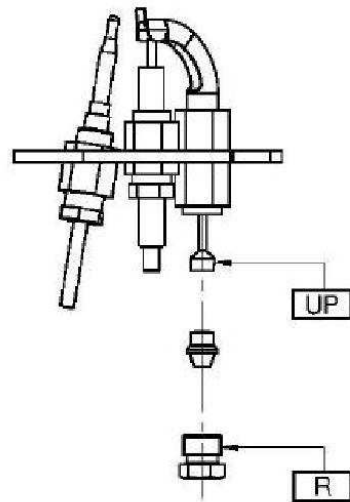
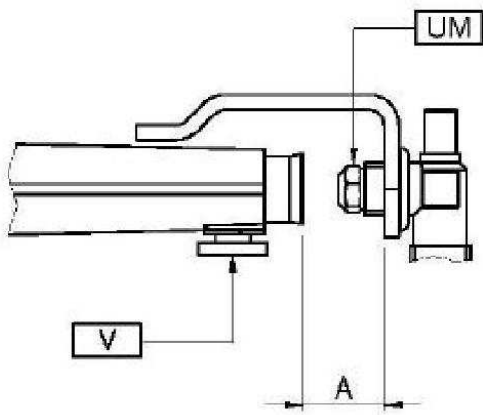
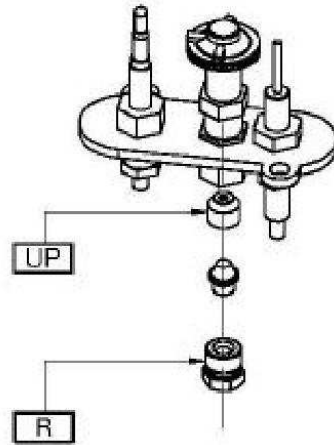
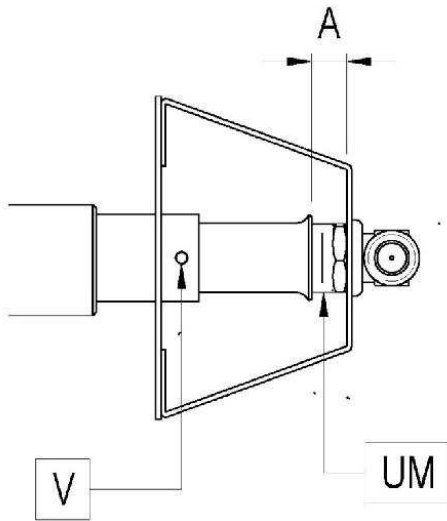
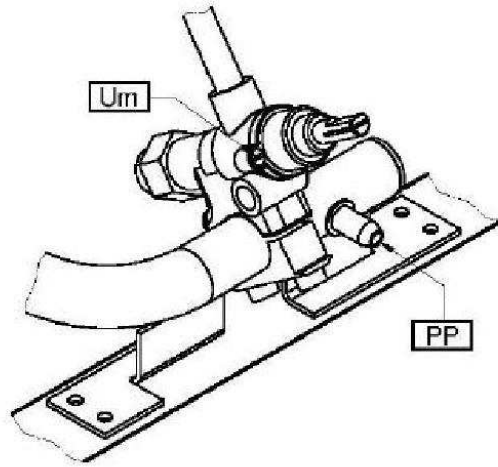

**VIII. TAB1 - DATI TECNICI - TECHNICAL DATA - TECHNISCHE DATEN - CARACTERISTIQUES TECHNIQUES - DATOS TECNICOS - TECHNISCHE GEGEVENS Ugelli e regolazioni - Nozzles and settings - Buses et les paramètres - Dusen und Einstellungen - Boquillas y los ajustes - Verstuivers en regelingen**

<b>TAB1</b>				
<b>Gas Gaz</b>	<b>Pa (mbar)</b>	<b>UM UP A Um</b>	<b>_65/40 GRG</b>	<b>_70/40 GRG...</b>
			<b>_65/70 GRG</b>	<b>_70/70 GRG...</b>
G20 G20/G25	20 20/25	UM	205L	205L
		UP	36	36
		A (mm)	10	10
		Um	REG	REG
G25	20	UM	225L	225L
		UP	36	36
		A (mm)	10	10
		Um	REG	REG
G25	25	UM	205L	220L
		UP	36	36
		A (mm)	10	10
		Um	REG	REG
G20	25	UM	-	-
		UP	-	-
		A (mm)	-	-
		Um	-	-
G25.1	25	UM	-	-
		UP	-	-
		A (mm)	-	-
		Um	-	-
G30/G31	28-30/37 28-30	UM	135L	135L
		UP	19	19
		A (mm)	10	10
		Um	110	100
G30/G31	37	UM	-	-
		UP	-	-
		A (mm)	-	-
		Um	-	-
G30/G31	50	UM	115L	115L
		UP	19	19
		A (mm)	10	10
		Um	110	100
G110	8	UM	480L	480L
		UP	75	75
		A (mm)	1	1
		Um	REG	REG
G120	8	UM	400L	400L
		UP	75	75
		A (mm)	18	18
		Um	REG	REG

**Pa** : Pressione di allacciamento - Anschlussdruck - Supply pressure - Pression de raccordement - Presión de conexión - Aansluitdruck  
**UM** : Ugello MAX - Duse MAX - MAX nozzle - Buse MAX - Boquilla MAX - Sproeier MAX  
**Um** : Ugello MIN - Duse MIN - MIN nozzle - Buse MIN - Boquilla MIN - Sproeier MIN  
**UP** : Pilota - Zündbrenner - Pilot - Veilleuse gaz - Piloto - Waakvlam  
**A** : Apertura Aereatore - Öffnen Lufring - Aerator Opening - Ouverture Aérateur - Abertura del aireador - Opening beluchter  
**REG** : Regolato - Eingestellt - Regulated - Règie - Regulado - Geregeld

TAB1					
Gas Gaz	Pa (mbar)	UM UP A Um	_60/30 GRL	_65/40 GRL	_70/40 GRL
			_60/60 GRL	_65/70 GRL	_70/70 GRL
G20 G20/G25	20 20/25	UM	175L	175L	205L
		UP	51	27	36
		A (mm)	10	10	10
		Um	200	REG	REG
G25	20	UM	195L	195L	235L
		UP	51	27	36
		A (mm)	10	10	10
		Um	200	REG	REG
G25	25	UM	185L	180L	220L
		UP	51	27	36
		A (mm)	10	10	10
		Um	200	REG	REG
G20	25	UM	165L	-	195L
		UP	51	-	36
		A (mm)	10	-	10
		Um	200	-	REG
G25.1	25	UM	195L	-	220L
		UP	51	-	36
		A (mm)	10	-	10
		Um	200	-	REG
G30/G31	28-30/37 28-30	UM	120L	120L	140L
		UP	30	19	19
		A (mm)	10	10	10
		Um	110	110	100
G30/G31	37	UM	110L	-	130L
		UP	30	-	19
		A (mm)	10	-	10
		Um	110	-	100
G30/G31	50	UM	105L	100L	120L
		UP	30	19	19
		A (mm)	10	10	10
		Um	110	90	100
G110	8	UM	350L	350L	450L
		UP	62	75	75
		A (mm)	10	-	9.5
		Um	REG	REG	REG
G120	8	UM	330L	325L	400L
		UP	62	75	75
		A (mm)	10	-	9.5
		Um	REG	REG	REG

Pa : Pressione di allacciamento - Anschlussdruck - Supply pressure - Pression de raccordement - Pressión de conexión - Aansluitdruck  
UM : Ugello MAX - Duse MAX - MAX nozzle - Buse MAX - Boquilla MAX. - Sproeier MAX  
Um : Ugello MIN - Duse MIN - MIN nozzle - Buse MIN - Boquilla MIN - Sproeier MIN  
UP : Pilota - Zündbrenner - Pilot - Veilleuse gaz - Piloto - Waakvlam  
A : Apertura Aereatore - Öffnen Luftring - Aerator Opening - Ouverture Aérateur - Abertura del aireador - Opening beluchter  
REG : Regolato - Eingestellt - Regulated - Règie - Regulado - Geregeld



**TAB1**

<b>Gas Gaz</b>	<b>Pa (mbar)</b>	<b>UM UP A</b>	<b>_90/40 GRL _90/80 GRL</b>
G20 G20/G25	20 20/25	UM	235
		UP	36
		A (mm)	10
		Um	REG
G25	20	UM	260
		UP	36
		A (mm)	10
		Um	REG
G25	25	UM	245
		UP	36
		A (mm)	10
		Um	REG
G20	25	UM	220
		UP	36
		A (mm)	10
		Um	REG
G25.1	25	UM	245
		UP	36
		A (mm)	10
		Um	REG
G30/G31	28-30/37 28-30	UM	155
		UP	19
		A (mm)	10
		Um	100
G30/G31	37	UM	145
		UP	19
		A (mm)	10
		Um	100
G30/G31	50	UM	135
		UP	19
		A (mm)	10
		Um	100
G110	8	UM	470
		UP	75
		A (mm)	9.5
		Um	REG
G120	8	UM	430
		UP	75
		A (mm)	9.5
		Um	REG

**Pa** : Pressione di allacciamento - Anschlussdruck - Supply pressure - Pression de raccordement - Presión de conexión - Aansluitdruk

**UM** : Ugello MAX - Duse MAX - MAX nozzle - Buse MAX - Boquilla MAX. - Sproeier MAX

**Um** : Ugello MIN - Duse MIN - MIN nozzle - Buse MIN - Boquilla MIN - Sproeier MIN

**UP** : Pilota - Zündbrenner - Pilot - Veilleuse gaz - Piloto - Waakvlam

**A** : Apertura Aereatore - Öffnen Luftring - Aerator Opening - Ouverture Aérateur - Abertura del aireador - Opening beluchter

**REG** : Regolato - Eingestellt - Regulated - Règie - Regulado - Geregeld

**IX. TAB2 - DATI TECNICI - TECHNICAL DATA - TECHNISCHE DATEN - CARACTERISTIQUES TECHNIQUES - DATOS TECNICOS - TECHNISCHE GEGEVENS** Categoria e pressioni - Categories and pressures - Catégories et pressions - Kategorien e Druck - Las categorías y las presiones - Categorieën en druk

Paese Land Country Pays Pais	Categoria Kategorie Category Catégorie Categoria Categorie	Gas-Gaz	Pressione di allacciamento Anschlussdruck Supply pressure Pression de raccordment Pression de connexion Aansluitdruck (mbar)		
			Nom. Neen. Norm. Normal	Min.	Max
PL	I2E	G20	20	17	25
LU CY	I3+	G30/G31	28-30/37	20/25	35/45
NO CY MT IS HU	I3B/P	G30/G31	28-30	25	35
PL	I3B/P	G30/G31	37	25	45
BE FR	II2E+3+	G20/G25	20/25	17/20	25/30
		G30/G31	28-30/37	20/25	35/45
DE	II2ELL3B/P	G20	20	17	25
		G25	20	18	25
		G30/G31	50	42,5	57,5
ES GB GR IE IT PT SK CH	II2H3+	G20	20	17	25
		G30/G31	28-30/37	20/25	35/45
MK UA FI BG EE LV LT CZ SI TR HR RO SK SE DK AL NO RA	II2H3B/P	G20	20	17	25
		G30/G31	28-30	25	35
AT CH	II2H3B/P	G20	20	17	25
		G30/G31	50	42,5	57,5
HU	II2HS3B/P	G20	25	18	33
		G25.1	25	18	33
		G30/G31	28-30	25	35
		G30/G31	50	42,5	57,5
SE	III1ab2H3B/P	G20	20	17	25
		G30/G31	28-30	25	35
		G110	8	6	15
		G120	8	6	15
DK IT	III1a2H3B/P	G20	20	17	25
		G30/G31	28-30	25	35
		G110	8	6	15
NL	II2L3B/P	G25	25	20	30
		G30/G31	28-30	25	35
LU	II2E3+	G20	20	17	25
		G30/G31	28-30/37	20/25	35/45

**X. TAB3 - DATI TECNICI - TECHNICAL DATA - TECHNISCHE DATEN - CARACTERISTIQUES TECHNIQUES - DATOS TECNICOS - TECHNISCHE GEVEGENS** Dati tecnici apparecchiature gas - Technical data of gas appliances - Caractéristiques techniques des appareils à gaz - Technische Daten gasgerate - Datos técnicos de los equipos de gas - Technische gegevens gasapparatuur

TAB3													
Modelli Modelle Models Modeles Modelos Modellen	Larghezza Breite Width Largeur Anchura Breedte	ΣQn	Σqn G110 (8)	Consumo gas complessivo - Gesamtgasverbrauch Total gas consumption Consumation totale de gaz - Consumo total de gas - Totaal gasverbruik									
				G20 (20)	G25 (25)	G25 (20)	G20 (25)	G25.1 (25)	G110 (8)	G120 (8)	G30 (29)	G30 (37)	G30 (50)
				mm	kW	kW	m3/h	m3/h	m3/h	m3/h	m3/h	m3/h	m3/h
_60/30 GRL	300	5.5	5.5	0.58	0.68	0.68	0.58	0.68	1.42	1.26	0.43	0.43	0.43
_60/60 GRL	600	11	11	1.16	1.35	1.35	1.16	1.35	2.84	2.53	0.87	0.87	0.87
_65/40 GRG	400	7.5	-	0.79	0.92	0.92	0.79	0.92	-	-	0.59	0.59	0.59
_65/70 GRG	700	15	-	1.59	1.85	1.85	1.59	1.84	-	-	1.18	1.18	1.18
_65/40 GRL	400	5.5	-	0.58	0.68	0.68	0.58	0.68	-	-	0.43	0.43	0.43
_65/70 GRL	700	11	-	1.16	1.35	1.35	1.16	1.35	-	-	0.87	0.87	0.87
_70/40 GRG...	400	7.5	7.5	0.79	0.92	0.92	0.79	0.92	1.94	1.72	0.59	0.59	0.59
_70/70 GRG...	700	15	15	1.59	1.85	1.85	1.59	1.84	3.87	3.44	1.18	1.18	1.18
_70/40 GRL...	400	7.5	7.5	0.79	0.92	0.92	0.79	0.92	1.94	1.72	0.59	0.59	0.59
_70/70 GRL...	700	15	15	1.59	1.85	1.85	1.59	1.84	3.87	3.44	1.18	1.18	1.18
_90/40 GRL	400	9.5	9.5	1.01	1.17	1.17	1.01	1.17	2.45	2.18	0.75	0.75	0.75
_90/80 GRL	800	19	19	2.01	2.34	2.34	2.01	2.33	4.90	4.36	1.50	1.50	1.50

**XI. TAB4 - DATI TECNICI - TECHNICAL DATA - TECHNISCHE DATEN - CARACTERISTIQUES TECHNIQUES - DATOS TECNICOS- TECHNISCHE GEGEVENS** Dati tecnici apparecchiature elettriche - Dati tecnici aTechnical data of electric appliances - Caractéristiques techniques des appareils électriques - Technische Daten Elektrogerate - Datos técnicos de los equipos eléctricos - Technische gegevens elektrische apparatuur

TAB4						
Modelli Modelle Models Modelos Modellen	Larghezza Breite Width Largeur Anchura Breedte	Tensione di alimentazione Netzspannung Power supply voltage Tension d'alimentation Tension de alimentacion Voedingsspanning	Fasi Phasen Phases Fases Fasen	Frequenza Frequenz Frequency Fréquence Frecuencia Frequentie	Potenza totale massima Max. gesamtleistung Max. total power Puissance totale maximum Potencia maxima total Max totaal vermogen	Sezione cavo alimentazione Querschnitt netzkabel Power supply cable section Section du cable de alimentation Section del cable de alimentacion Doorsnede elektrisch snoer
	mm	V	Nr. No. Nbre N. A ant.	Hz	kW	-
_70/40 GRACQE	400	380-415	3N	50-60	6.00	5 G 1
_70/80 GRACQE	800	380-415	3N	50-60	12.00	5 G 2.5
_90/40 GRACQE	400	380-415	3N	50-60	7.50	5 G 1.5
_90/80 GRACQE	800	380-415	3N	50-60	15.00	5 G 2.5