

Mod: MY15-20-25-30-35-40

Production code: MY15BHO-20-25-30-35-40

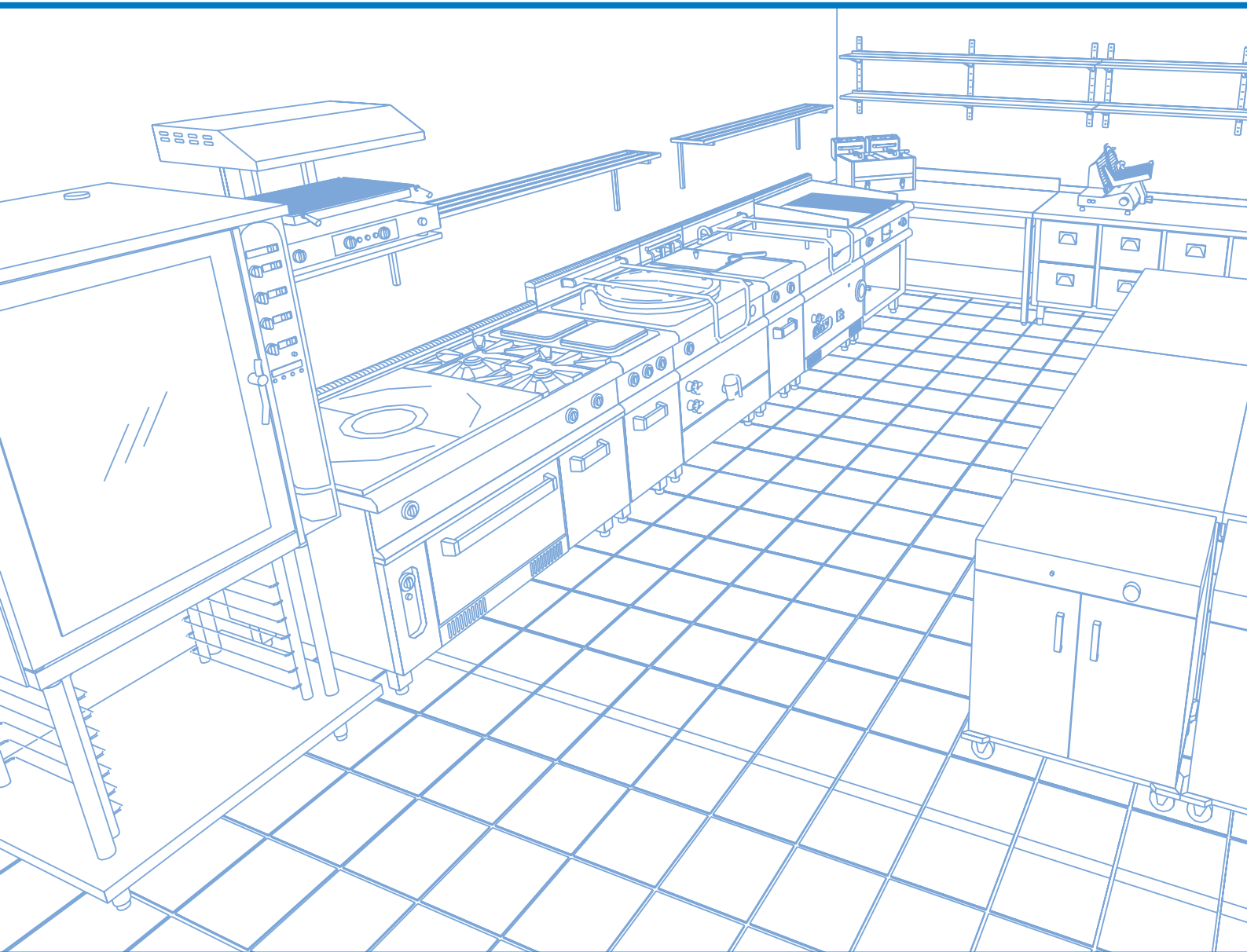



HANDLING AND TRANSPORT

The equipment is packed in a wooden box which is suitable for lifting by fork lifts or transpallette in order to avoid possible damages. The wooden packing can be recycled, therefore it has to be disposed in the special waste plan for recycling. It is advisable to use a wooden board for any handling of the cabinet in order to avoid damages of the structure.

COMPLAINTS

On receipt of the refrigerated equipment verify immediately, by unpacking carefully the unit, if there are transport damages. In case the unit is damaged in any way, notify immediately the driver and, within 3 days, the shipping company by registered letter. Carefully unpack the unit, paying attention so as not to damage it or throw parts and /or accessories (i.e screws) away. Every complaint must arrive at the manufacturer within 8 days from receipt of the equipment.

IMPORTANT INSTRUCTIONS AND SUGGESTIONS

Before using the equipment it is important to read these instructions carefully as improper use can be dangerous. Before connecting the refrigerated unit, make sure that the power supply voltage is as indicated on the label (fig. C). The equipment **MUST** be connected to a grounded power socket, in compliance with the current legislation to satisfy the safety requirements.

For usage of the unit, as every electrical device, basic rules have to be followed :

- do not touch or plug the equipment with damp or wet hands or feet;
- do not pull the electric cable to unplug it;
- do not expose it to the atmospheric agents;
- do not allow children to use it without adult supervision;
- **before starting any cleaning or maintenance operation, it is necessary to unplug the equipment and do not attempt to make any modification.**

WORKING TEMPERATURE

This equipment is manufactured in conformity with the ambient conditions of climatic class 3 (25° C - 60% R.H.) EN 441 - 4. The refrigerated unit maintains its performance characteristics with an ambient temperature and relative humidity of no more than: + 25° C and 60% R.H. (relative humidity). In case the ambient conditions are not included in the above mentioned ones, a lower performance must be expected.

CLEANING

Before switching on the unit, clean the equipment thoroughly, both inside and outside including the gasket of the door, using warm water and a solution of bicarbonate of soda (1 tea spoon every 2 liters) or white vinegar. Carefully dry the unit with a soft cloth; never use metal pads or abrasive substances. Never use sharp objects; any damage resulting from the use of these objects will not be covered by warranty.

ELECTRICAL POWER / CONNECTION

First of all, make sure that there is an efficient ground system in compliance with the current legislation regarding electrical safety.

When in doubt, request a careful check from a qualified technician. The unit is equipped with the plug and the electrical cable mod. Schuco (fig. D). The necessary operations are :

- 1) verify that the power supply voltage is as indicated on the machine rate plate (fig. C 230V - 50 H monophase)
- 2) **in case of incompatibility between the socket and the plug of the unit, the plug should be replaced with a suitable one by a qualified technician**
- 3) do not connect any other appliance to the same power socket
- 4) do not pull the electrical cable or the unit to unplug the equipment from the socket (fig. E).
- 5) Pay attention that the power supply cable is laid in such a way as to prevent it from being damaged or becoming hazardous to people and things.

THE MAIN POWER SUPPLY LINE CAN BE ALTERED ONLY BY A QUALIFIED TECHNICIAN.

- 6) In case the power supply cable is damaged, it should be replaced only by a qualified technician.

INSTALLATION

The refrigerated unit must be installed in a suitable dry place and on a level floor (Fig. G) to avoid an higher energy consumption and a shorter compressor life.

It must be installed on a level floor to prevent noise, bad working and, during the fitting phase, the problems with alignment of the glass structure holes (on the pistons version the glasses could not close perfectly or be broken). The refrigerated equipment should never be installed:

- a - near sources of heat such as radiators, direct or indirect sunlight or other equipment which produces heat (fig. F);
 - b - in line with draughts coming from doors, windows or air conditioning systems (fig. F).
- Do not close or obstruct the ventilation openings of the refrigeration unit.

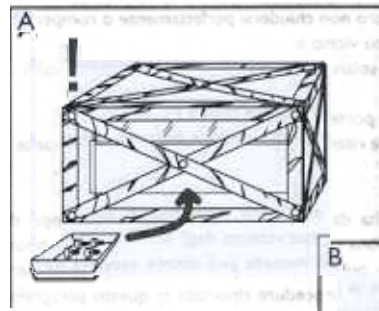

C

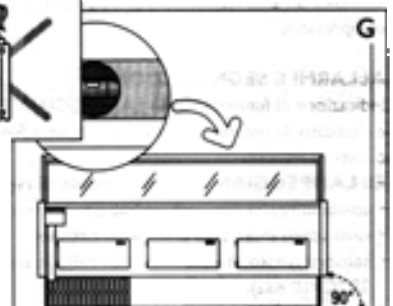
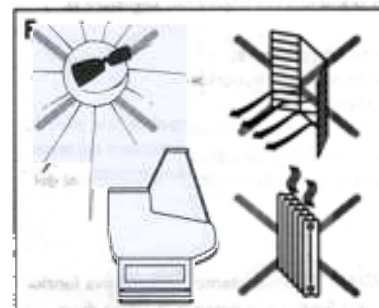
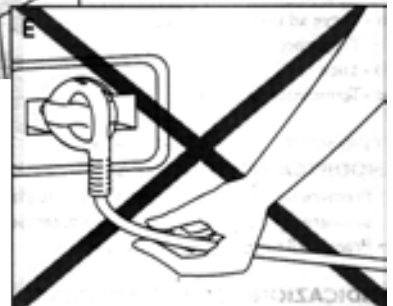
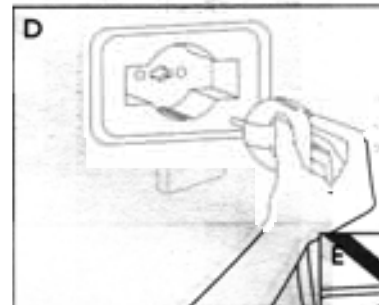

PERIODICAL MAINTENANCE

We suggest to carry out a thorough cleaning of the counter once a month for the good working, the good preservation of the food and the aesthetics preservation of the equipment. The periodical cleaning can be made by qualified people, who should know the procedure described in this paragraph. **ATTENTION!** Before starting any cleaning operation it is necessary to turn off the equipment by the on / off red switch (see picture I) and to unplug or disconnect the equipment by the general power security switch of your shop. During the whole cleaning operation we suggest to use working gloves to protect your hand all the time.

To carry out the cleaning it is necessary :

- 1 - to remove all goods from the refrigerated unit and to keep them in a freezzer or in a refrigerated ambient suitable for their preservation;
- 2 - to unplug or disconnect the main on / off switch, disconnect the plug from the power socket and wait until the equipment temperature reaches the room temperature;
- 3 - carefully and thoroughly clean the display surface, the refrigerated storage, the glasses, the aluminium profile, the door gasket with specific cleaners for any surface. Never use abrasive substances, metal pads or other stuff which can damage the unit.
- 4 - After every cleaning operation it is necessary to rinse with warm water and dry the unit with a soft cloth;
- 5 - to clean the condenser too, use a dry paint brush and /or a vacuum cleaner, removing all dust. Pay attention not to bend or damage the fins, the tubes or the blades of the fans. When the cleaning operation is over, make sure that everything is clean and dry before connecting the equipment to the power supply again. When the unit reaches the correct working temperature, it is possible to reload it. In case of long absences (i.e. holidays etc.) the unit has to be unplugged, emptied completely, cleaned and dried. Make sure to leave the doors open to prevent bad smells.

DEFROSTING

The defrosting takes place automatically during the running of the unit. The defrosting cycles are 4 a day, last for about 40' each and are controlled by a timer in the electrical control panel. During the defrosting phase the temperature of the unit could be altered, but when this cycle is over, in a short time the working temperature will return to normal. The water from defrost is collected in a removable drip tray which should be emptied when necessary.

CONTROL DEVICES

- a - On / Off switch
- b - Lighting
- c - Electronic thermostat

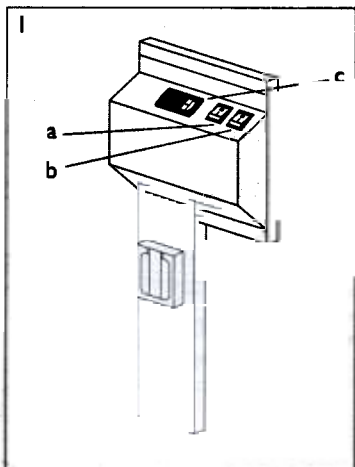

ELECTRONIC THERMOSTAT

TEMPERATURE MODIFICATION

- Press for 5 seconds to display the selected parameter value; press to reach the required temperature;
- Press to confirm.

INDICATION ON THE DISPLAY

There are three LEDs of button back-lightening which display the operating status of the instrument, available only for TOP versions. For cheap versions, only one segment of the display signals compressor ON.

- Button Led indicates compressor ON
- Button Led indicates defrosting ON
- Button Led indicates presence of alarms.

The blinking status means that the corresponding function is delayed by a timed routine. A particular blinking of the button indicates that the manual request of Continuous Cycle is delayed by the compressor timed routines.

ALARMS AND SIGNALS

BLINKED functioning LED

- If a LED blinks it means that the corresponding function is delayed by a timed routine, by another procedure or inhibited by the digital input.

E0 BLINKS faulty regulation probe:

- Used probe is not compatible with the control;
- The probe cable is interrupted or short circuited;
- Faulty sensor: take out the probe from the control and verify the resistance (NTC: $25^{\circ}\text{C}=10\text{K}\Omega$).

E1 BLINKS faulty evaporator probe or food probe:

- Used probe is not compatible with the control;
- The probe cable is interrupted or short circuited;
- Faulty sensor: take out the probe from the control and verify the resistance (NTC: $25^{\circ}\text{C}=10\text{K}\Omega$).

IA BLINKS immediate external alarm:

- Check the "Mutifunction" input and the A4 and A7 parameters.

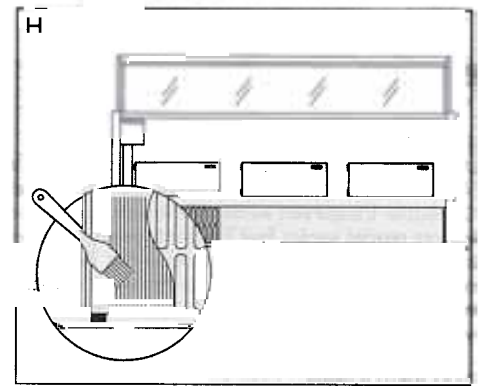

LO BLINKS low temperature alarm (temperature less than SET-AL):

- Verify the AL, Ad and A0 parameters;
- The alarm disappears as soon as the temperature rises and ranges within the selected limits.

HI BLINKS high temperature alarm (temperature higher than SET+AH):

- Verify the AH, AD and A0 parameters;
- The alarm disappears as soon as the temperature decreases and ranges within the selected limits.

EE data acquisition failure, controller RESET:

Set again the default parameters value, to restore correct operation. Re-setting the default values causes the loss of the modifications relative to the working parameters.

- switch-OFF the control;
- Press the and buttons while switching on the control; "-CF" is displayed;
- After a few seconds the instrument enters the RESET phase and starts to work.

Ed BLINKS timeout defrost:

- Verify the dt, dP and d4 parameters;
- Verify defrost efficient.

dF BLINKS defrost currently ON:

- It is not an alarm signal. It simply indicates a defrost cycle in progress. It appears only if the parameter d6=0.

TEMPERATURE

The thermostat, which is situated on the electrical control panel, regulates the temperature into the equipment and is usually preset to $+0 / +6\text{C}^{\circ}$ at the factory during the testing phase.

A lower performance must be expected from the refrigerated unit when:

- the equipment is set on the lowest temperature
- the equipment is positioned in an ambient with higher temperature or relative humidity than above indicated
- the amount of displayed goods exceeds the maximum recommended and the proper air circulation is prevented.

In those cases the goods are kept at higher temperatures, the refrigerating unit has to run non - stop and ice may form on the evaporator. It is necessary therefore to turn the equipment off (approx. 24 hours) to allow the melting of the ice.

TECHNICAL ASSISTENCE (servicing)

If the equipment does not run properly or does not work at all, in your own interest before calling for servicing, we suggest to check the following points:

- if the plug is well inserted in the socket;
- if the power reaches the socket to which the equipment is connected;
- if the thermostat is set as recommended;
- if the doors are perfectly closed;
- if the network voltage is the same as requested for the unit ($\pm 6\%$).

DISMANTELLING OF EQUIPMENT

The demolition of the unit and the recovery of the component materials must be carried out according to the regulation in force in this matter. Considering that the equipment is formed by many different materials (i.e ABS with polyurethane foam for isolation, glass, stainless steel, aluminium, copper etc.) and some of them are like normal urban waste materials while other components, as refrigeration gas and oil, MUST be given to a special recycling center.

REPLACEMENT OF LAMPS

The replacement and the substitution of lamps must be made by qualified technician and when the unit is disconnected from the power net. Disconnect the main power supply before fitting or replacing the lamp. Slip the ring nuts onto the fluorescent lamp. Fit the lamp in the lampholder and turn it 90° . Slide the ring nuts along the lamp until they rest on the lampholder and turn them clockwise (NPP and NPQ); screw down tightly (NPW).