

05/2016

Mod: P42/XV

Production code: P05RP24015



P42/XVM – M42A



**P32/X – RM32A
P42/X – RM42A**



P42/XV – P42TA

Manuale di istruzione

**Notice d'utilisation
Instruction manual
Handleiding
Instrukcja obsługi**

**Manual de instruções
Руководство по эксплуатации
Manual de instrucciones
Gebrauchsanweisungen**

ENGLISH

DECLARATION OF CONFORMITY

In agreement with the Low Voltage Directive **2006/95 EEC**, with the directive **2004/108 EEC** (EMC9), with the directive **2006/42 EEC** (machines), integrated by the CE mark.

In agreement with Regulation (EC) No. **1935/2004** of the European Parliament and of the Council of **27 October 2004** on materials and articles intended to come into contact with food.

Type of appliance / Machine	DILAMINATRICI
Trademark	DIAMOND
Model	P42/XVM-P32/X-P42/X-P42/XV M42A-RM32A-RM42A-RM42TA
Manufacturer	PIZZA GROUP SRL

The harmonised standards or technical specifications (designations) that have been applied in agreement with the highest professional standards on safety in force in the EEC are:

Standards or other normative documents

EN 55014-2:2006; EN 55014-2:1997 + A1:2001 + A2:2008;
EN 60335:2002 + A1:2004 + A12:2006 + A2:2006 + A13:2008 +FprAF:2009;
EN 60335-2-64:2000 + A1:2002;
EN ISO 12100-1:2009; EN ISO 12100-2:2009;
EN 62233:2003

Other information:

In my capacity as manufacturer and/or authorised representative of the company inside the EEC, I hereby declare, under my own responsibility that the appliances conform to the essential requirements of the aforementioned Directives.

1 LEGAL WARRANTY

The period of warranty is in agreement with the European community standards and starts from the date of the invoice issued at the time of purchase.

Within such period all components that have unequivocal and well ascertained manufacturing flaws will be replaced or repaired free of charge exclusively by our plant. The guarantee does not include electrical components and those subject to wear and tear.

Shipping and labour costs are not included in the warranty.

In order to make use of the legal warranty the user must strictly observe the instructions contained in this manual, as outlined in Directive 1999/44/CE, and more specifically:

- always operate the oven according to its intended use;
- always carry out constant and accurate maintenance;
- allow only skilled and properly trained personnel to use the oven

Failure to comply with the instructions provided in this manual will cause the warranty to be considered immediately null and void.

2 SAFETY RECOMMENDATIONS

2.2 WARNINGS FOR THE INSTALLER

⚠ Check that the location of the machine is in compliance with local, national and European regulations.

- Adhere to the instructions in this manual.
- Do not execute electrical connections using temporary or uninsulated cables.
- Check that the ground connection of the electric system is working properly.
- Always use individual safety devices and other means of protection in compliance with the law.

2.3 WARNING FOR THE USER

⚠ The conditions of the area where the machine is to be installed must have the following characteristics:

- the area must be dry;
- water and heat sources must be at a safe and proper distance;
- ventilation and lighting must be suitable and comply with the hygiene and safety standards foreseen by current laws;
- the floor must be flat and compact to facilitate thorough cleaning;
- there must be no obstacles of any kind in the immediate vicinity of the machine that could affect the machine's normal ventilation.

In addition, the user must:

- make sure to keep children away from the machine while it is operating;
- adhere to the instructions in this manual.
- not remove or tamper with the safety devices on the machine;
- always pay careful attention to the work at hand and do not use the machine absent-mindedly;
- perform all operations with maximum safety and calm;

- respect the instructions and warnings displayed on the machine labels.
The labels are accident prevention devices and must therefore always be perfectly legible. Should they be damaged and illegible, it is mandatory to replace them requesting replacements from the Manufacturer.
- At the end of each working shift, disconnect electrical power before cleaning or doing any maintenance or transfer operations.



WARNING: while the machine is under working, it is strictly forbidden to remove the security protections, because of the presence of moving parts which can cause hands crashing.

⚠ WARNING:

**RISK OF CRASHING COULD STILL REMAIN ALSO IF THE MACHINE IS EQUIPPED WITH A SAFETY PROTECTION.
DON'T INTRUDE ARTS OR ANY OTHER PARTS OF THE BODY TO THE INTERNAL PROTECTION OF THE ROLLS.**

TRAIN PERSONNEL TO USE THE MACHINE, BRINGING AWARE OF THE RISKS, IN ORDER TO AVOID DANGER OF DAMAGE TO PERSONS AND PROPERTY.

2.4 WARNINGS FOR THE MAINTENANCE OPERATOR

- ⚠** Observe the instructions indicated in this manual.
- Always use individual safety devices and other protection means.
 - Before starting any maintenance operations, make sure that the machine, if it was used, has cooled down.
 - Disconnect electrical power before intervening on electrical or electronic parts and connectors.
 - If any of the safety devices is worn or faulty, the machine is also considered faulty and is not to be used.

3 MOVEMENT AND TRANSPORT

The machine is provided with all necessary parts in a closed package attached to a wooden pallet with straps.

The machine must be unloaded from the transport vehicle, lifting it with suitable equipment. To transport the machine to its installation area, use a rolling cart with suitable load capacity. During lifting operations, avoid sudden movements.

Make certain that the lifting means have a load capacity that is superior to the weight of the machine to be lifted.

The operator maneuvering the lifting equipment is responsible for lifting the load. Leave a free space of approximately 50 cm around the machine to facilitate use, cleaning and maintenance operations.

DANGER

- ⚠ **Make sure that children do not play with the packaging materials (for example, plastic film and styrofoam). Suffocation danger!**

4 PREPARATION OF THE INSTALLATION AREA

4.3 SAFETY PRECAUTIONS

⚠ Responsibility for operations executed in the room where the machine is installed is and remains of the user. The user is also responsible for the execution of controls related to the installation of the machine.

The user must comply with all local, national and European safety regulations.

The equipment must be installed on floors with adequate load capacity.

The assembly and disassembly instructions for the rolling machine are intended for specialized technicians.

It is always recommended that users contact our assistance service for technical requests.

Prior to starting machine assembly or disassembly, the installer must respect safety precautions in compliance with the law, and in particular must:

- A) not operate in unfavourable conditions;
- B) operate in perfect psycho-physical conditions and check that the individual accident prevention devices work perfectly;
- C) wear accident prevention gloves;
- D) wear accident prevention footwear;
- E) use electrically insulated tools;
- F) make sure that the area used for assembly and disassembly is free of any obstacles.

4.4 OVEN INSTALLATION'S LOCATION

The picture below shows the minimum distances that must be respected when positioning the machine in order to facilitate its use, cleaning and maintenance.

! The minimum distance between the machine and surrounding walls or other devices must be of approximately 50 cm.

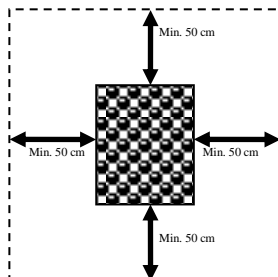

5 INSTALLATION

Installation must be executed by qualified personnel in compliance with local, national and European regulations.

5.3 MACHINE POSITIONING

Ensure that the machine is put on a flat stand with a suitable carrying capacity.

After unpacking the rolling machine, put it in the prepared location, keeping in mind the minimum distances (see point 4.2) to be respected. Remove any polystyrene protections and **take off the protecting film (F)**. Avoid using tools which might damage the surfaces.

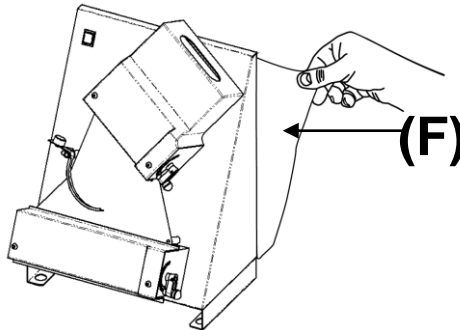

5.4 EQUIPMENT HOOK-UP

5.4.1 Electrical connection

Just connect the electricity-supply cable to the electricity network.

The electrical outlet must be easily accessible, no moving should be necessary.

! The electrical connection (plug) must be easily accessible, also after oven installation.

The distance between the oven and the socket must be suitable, as not to cause tension in the power supply cable. The cable, moreover, must not be located beneath the machine support base.

! If the electrical power supply cable is damaged, it must be replaced by the technical assistance service or by a qualified technician to prevent any risks.

5.4.1.1 Ground connection

⚠ It is mandatory that the electrical system is equipped with a ground connection.

6 MACHINE START UP AND USE

6.1 CONTROL BOARD DESCRIPTION

Our rolling machines are provided with an electronic start/stop circuit board with control treadle.

The picture below shows the board's control buttons.

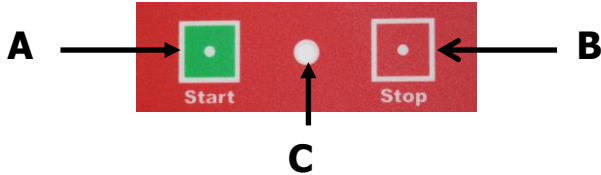

- D) **START** – start rollers
- E) **STOP** – stop rollers
- F) **PILOT LIGHT** - moving rollers

When the treadle lies on the floor you can also simply press and release the control treadle to start and stop the rollers.



6.2 WORKING PHASE

6.2.1 Thickness regulation

While the machine is not working, it is always possible to adjust the dough thickness parameters.

In order to do this, use the top and bottom rollers' regulation levers.

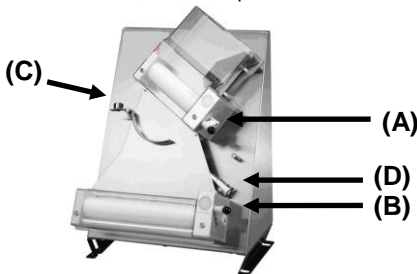

Roller regulation lever



To meet individual requirements, the machine can be regulated to various dough thickness values by turning the two levers (A and B) into position **Min to Max**.

To release the levers pull the black knob. The thickness varies according to the lever direction:

- **minimum thickness (-)** turn clockwise.
- **maximum thickness (+)** turn anticlockwise.

For the best result we suggest differentiating the adjustments, as in the example below:

- lever **(A)** in position **IV**;
- lever **(B)** in position **II**.

N.B. These regulations are simply an example, as the exact thickness needs to be determined through a few rolling-out trials, appraising the result each time.

The final result and the right thickness are influenced by the following variable conditions:

- dough texture;
- weight;
- thickness;
- size;
- dough disc shape.

⚠ All adjustments are to be done while the machine is still!

! WARNING: To avoid the dough being ragged, pass it just once through the rollers.

6.2.2 Shape regulation (not intended for models with parallel rollers)

In order to achieve a nice dough disc-shape, what is called for is adjusting the balancer group's (rod **D** + equalizer **C**) sensitivity to the dough weight changes. These adjustments allow regulating the dough's descent speed.

After loosening the locking screws, the counterweight **D** can slide up and down the rod allowing different balance calibrations.

Top sensitivity:

- let the counterweight slide towards the equalizer (i.e. towards the middle part of the rod)
- recommended for low weights.

Lowest sensitivity:

- let the counterweight slide towards the rod's tip (opposed to the equalizer)
- recommended for high weights.

After each adjustment tighten the screw again to lock the counterweight.

At this point, if necessary, regulate the equalizer's counterweight (C):

- Changing the equalizer's counterweight position, and hence the equalizer's sensitivity according to its position, requires loosening the locking screw.

Top sensitivity:

- move the counterweight towards the inside;
- recommended for low weights.

Intermediate sensitivity:

- put the counterweight in the middle;
- recommended for intermediate weights.

Lowest sensitivity:

- move the counterweight towards the outside;
- recommended for high weights.

After each adjustment tighten the screw again to lock the counterweight.

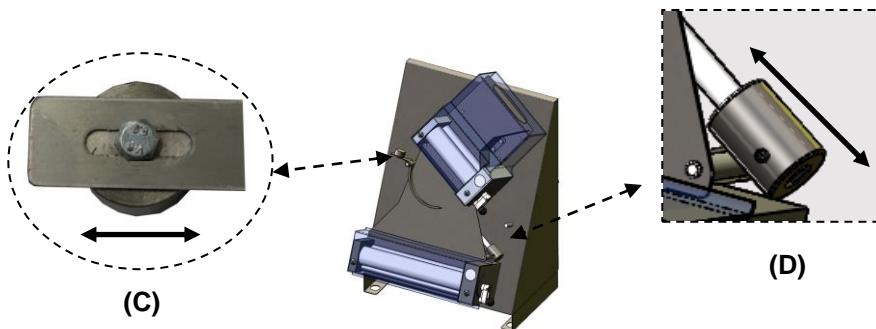

6.2.3 Work procedure



WARNING: while the machine is under working, it is strictly forbidden to remove the security protections, because of the presence of moving parts which can cause hands crashing.

Models with oblique top rollers

- 1) Press the control treadle to set the machine rollers going (for models without treadle push the START button on the circuit board to start the machine and the STOP button to stop it.)

- 2) Position the dough ball so that it passes smoothly through the top rollers (shape one side like a wedge to simplify the operation).
- 3) Passing through the top rollers the dough is shaped like a disc and gets the thickness (S) chosen by the operator.
- 4) Coming out of the top rollers, the dough slides onto the equalizer which drives it (turning it about 90°) towards the bottom rollers.
- 5) The bottom rollers press the disc once more until the desired thickness (S1) is reached.
- 6) The disc comes out of the bottom rollers and is to be collected by the operator.

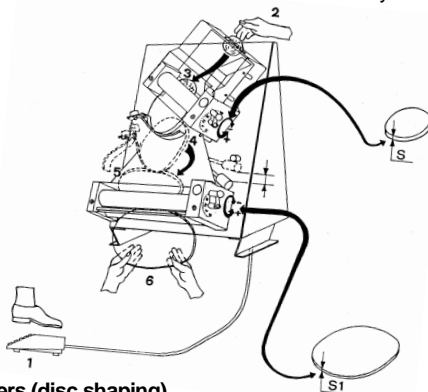

Models with parallel rollers (disc shaping)

- 1) Press the control treadle to set the machine rollers going (for models without treadle push the START button on the circuit board to start the machine and the STOP button to stop it.)
- 2) Position the dough ball so that it passes smoothly through the top rollers (shape one side like a wedge to simplify the operation).
- 3) When the dough is about to come out of the rollers, support the dough with one hand until it has come completely out. **At this point stop the rollers.** Once pressed by the top rollers the dough is shaped like a disc and gets the thickness (S) chosen by the operator.
- 4) Turn the dough about 90° with your hands, let it slide through the bottom rollers and set them going again, until the dough disc with the desired thickness (S1) comes out.
- 5) The dough disc slides out of the bottom rollers and is to be collected by the operator.

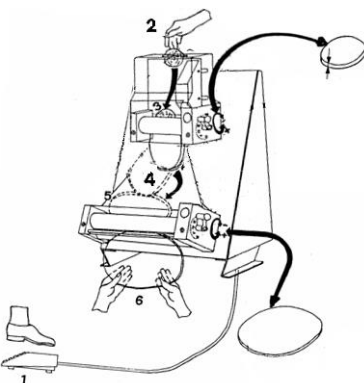

Models with parallel rollers (rectangle shaping)

Put a clean baking-tin under the rolling machine. It should be big enough to adapt to the steel feet.

- 1) Press the control treadle to set the machine rollers going (for models without treadle push the START button on the circuit board to start the machine and the STOP button to stop it.)
- 2) Position the dough ball so that it passes smoothly through the top rollers (shape one side like a wedge to simplify the operation).
- 3) After this step the dough thickness is reduced.
- 4) For intermediate and high weighed dough discs it is then necessary to keep spreading the dough by hand, accompanying it towards the lower rollers, until the dough comes out and falls onto the baking-tin.

N.B. In the single roller models (M35) the dough is pressed just once, as there is just one roller.

6.3 SHUT DOWN PHASE

To turn off the machine release the control treadle (in the models provided with it) or push the STOP button (in the models without treadle).

7 MAINTENANCE AND CLEANING

7.1 SAFETY PRECAUTIONS

- ! Before performing any maintenance operations take the following precautions:
- Ensure that the machine is not working and that it has completely cooled down.
 - Ensure that the machine is disconnected from electricity supply.
 - Make certain that the electrical power cannot be accidentally reconnected. Disconnect the plug from the socket.
 - Use individual protection devices in compliance with the directive 89/391/EEC.
 - Always use appropriate maintenance tools.
 - Once maintenance and repairs are finished, reinstall all protection devices and reactivate all safety devices before starting up the machine again.

7.2 ROUTINE MAINTENANCE FOR THE USER

As any equipment, also our machines require a simple yet frequent and careful cleaning to ensure an effective and regular functioning.

! It is recommended to never use abrasives, corrosives or chemical products which are not specific for food preparation areas. Avoid by all means using water jets, unspecific tools,

rough or abrasive instruments, such as steel wool or sponges or any other item which could damage the machine surface, especially those which could jeopardize health safety.

- Using a suitable brush, perform a first removal of flour and dough remainders.
- Remove the two protections, the balancing device and the chutes.
- Release the dough scraper springs.
- Pull out the dough scrapers.
- Turn the regulation levers opening the rollers to their maximum extent.
- Clean the machine and all the removed components using a sponge or cloth moistened with water and detergent.
- Carefully rinse until the detergent is completely removed.
- Dry with kitchen paper and then first go over the surfaces in contact with the dough and then the whole machine with a soft, clean cloth soaked with a disinfectant suitable for food processing machines.

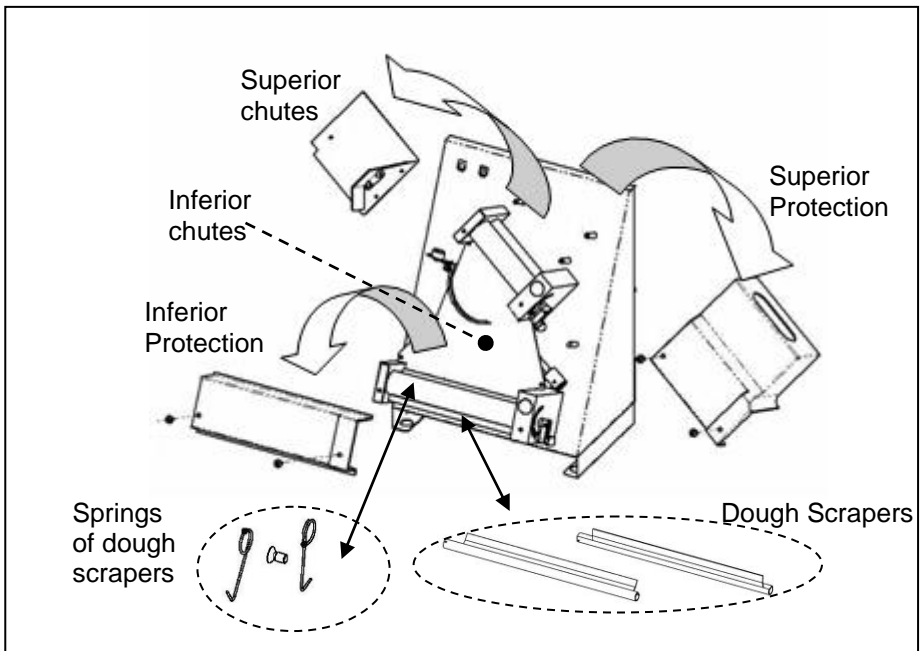

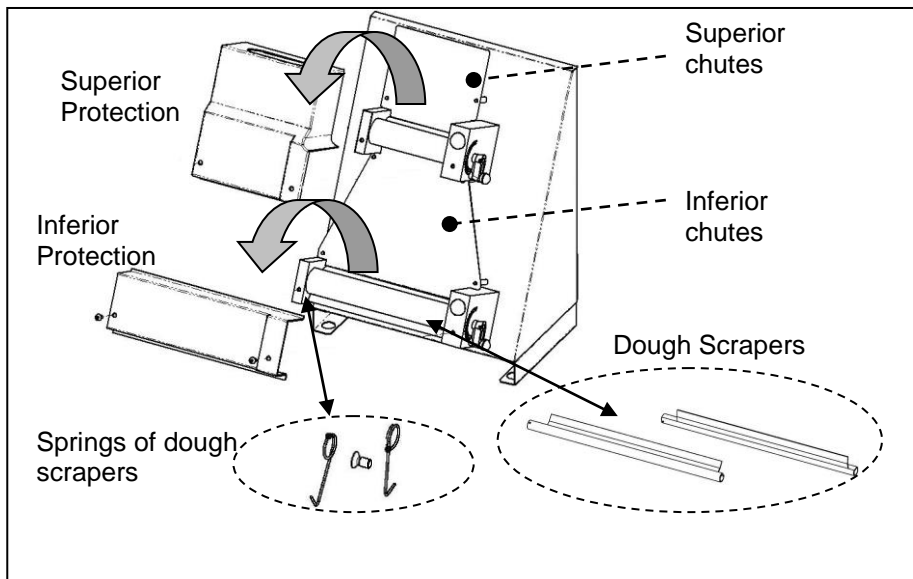

7.3 MAINTENANCE ADDRESSED TO QUALIFIED

Shafts and rollers must be lubricated once a year.

- Remove protections, chutes, springs and dough scrapers.
- Remove the back **A** (loosen the locking screws).
- Then remove supports **B** and **C**.
- Pull out rollers and joints.
- Clean all parts thoroughly using a sponge, warm water and a food grade detergent.
- Rinse sufficiently and dry with absorbent paper.
- Lubricate both shafts and rollers' holes with a suitable quantity of paraffin oil.
- Re-assemble and fix all previously removed components, working in the inverse order.

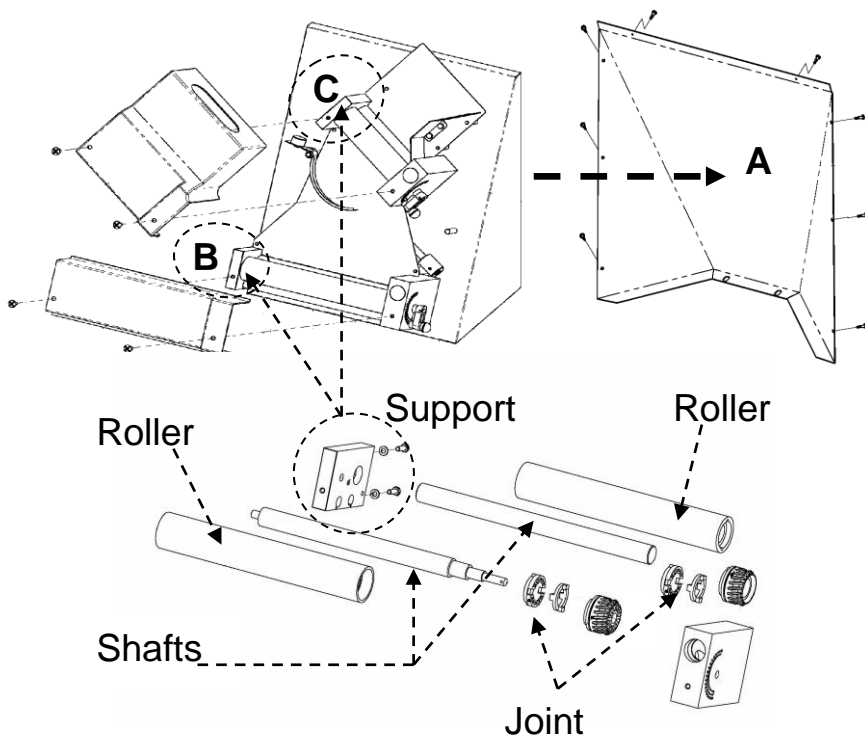

8 DEMOLITION AND DISPOSAL INFORMATION

Demolition and disposal of the machine are the sole responsibility of the owner, who must perform these tasks in compliance with the currently safety and environmental protection rules enforced in the Country where the machine is installed.

Disassembly and disposal can also be performed by a third party, as long as it is an authorized company for the recovery and demolition of the materials in question.

INSTRUCTION: *always adhere to the laws concerning the disposal of materials and, if needed, the disposal registration, currently enforced in the Country where the machine is installed.*

! WARNING: *All disassembly operations for demolition must take place when the machine is off and disconnected from the electrical power supply.*

- *remove all electric system components*
- *separate the accumulators of the electronic cards*
- *dispose of the machine frame through authorized companies.*

! **WARNING:** *Abandoning the machine in accessible areas seriously jeopardizes people and animals.
Responsibility for possible damage to people and animals falls exclusively on the owner.*

USER INFORMATION



This appliance is to be disposed of in compliance with the European directive 2002/96/EC, stating that this product must be disposed of separately from normal house waste. A suitable waste disposal and thus a correct recycling of the exhausted machine contribute avoiding a possible negative impact on environment and on health, while fostering the reuse or recycling of the equipment materials.

For further information about the disposal centres, please contact your local waste management office or your Dealer.