

07/2018

Mod: SB2/R2

Production code: 39130631000 / GSF10P



Diamond
catering equipment

Model: SA



Technical manual

UK

UK Contents

Important safety instructions	13
Unpacking and installation	13
Electrical connection	13
Start-up of the cabinet	14
Thermostat	14
Defrosting	15
Maintenance and cleaning	16
Service	16
Disposal	16
Dimensions	41
Technical data	44
Electrical circuit diagramme	45
Refrigeration system	46
Table of parameters	47



Important safety instructions

1. To obtain full use of the cabinet, we recommend reading this instruction manual.
2. It is the user's responsibility to operate the appliance in accordance with the instructions given.
3. Contact your dealer immediately in case of any malfunctions.
4. Place the cabinet in a dry and ventilated place.
5. Keep the cabinet away from strongly heat-emitting sources and do not expose it to direct sunlight.
6. Always keep in mind that all electrical devices are sources of potential danger.
7. Do not store inflammable material such as thinner, gasoline etc. in the cabinet.
8. We declare that no asbestos nor any CFC are used in the construction.
9. The oil in the compressor does not contain PCB.

Unpacking and installation

Remove the wooden pallet and the packing. External surfaces are supplied with a protection foil, which must be removed before installation

To ensure correct function it is important that the cabinet is level. The cabinet is supplied with legs, these can be adjusted. See fig. 1.1.

Fig. 1.1

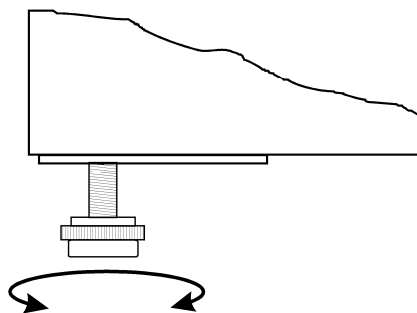

Electrical connecting

The cabinet operates on 230 V/50 Hz.

The wall socket should be easily accessible.

All earthing requirements stipulated by the local electricity authorities must be observed. The cabinet plug and wall socket should then give correct earthing. If in doubt, contact your local supplier or authorized electrician.

The flexible cord fitted to this appliance has three cores for use with a 3-pin 13-Amp or 3-pin 15-Amp plug. If a B.S. 1363 (13-Amp) fused plug is used, it should be fitted with a 13-Amp fuse.

The wires in this mains lead are coloured in accordance with the following code:
Green/Yellow: Earth, Blue: Neutral, Brown: Live.

The main electrical connections must be done by skilled electricians.

Start-up of the cabinet

Before use, we recommend that the cabinet is cleaned, see the section on maintenance and cleaning.

Important !

If the cabinet has been vertically placed during transport, please wait 2 hours before starting up the cabinet.

Connect the cabinet to a socket and turn on the switch on the control panel, see fig. 1.9.

Fig. 1.9

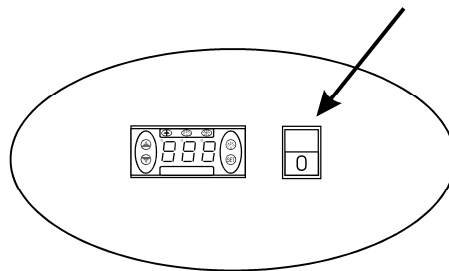

Thermostat

The thermostat is placed in the control panel, see fig. 2.0.

Fig. 2.0
DP2 DP1

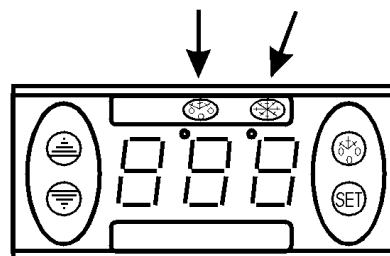

The thermostat has been pre-set and in most cases it is not necessary to adjust the settings.

When turning on the cabinet the display will show the current temperature in the cabinet.

Indications LED's:

DP1: Flashing, indicates that a parameter is being changed
 Switched on, indicates that the compressor is activated

DP2: Switched on, indicates that defrosting is activated.

Keyboard lock:

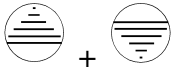

To lock or unlock the keyboard, press these keys simultaneously for about 5 seconds (to lock the display reads 'Pof', to unlock the display reads 'Pon').

Display set temperature:



Press this key and the display will show the set temperature. Press the key again to return to normal reading

Set new temperature:



Press this key and the display shows the set temperature.



Press this key to increase the set temperature.



Press this key to lower the set temperature.



Press this key to save the new settings. The display will flash with the new value and will then return to normal reading.

Changing of parameters:



Press this key continuously for 5 seconds to access the list of parameters. The display will show the number of the parameter and after 2 seconds the value.



Press this key to increase the value.



Press this key to lower the value.



Press this key to save the new settings. The display will flash with the new value and will then return to normal reading.

See table of parameters from page 47.

Alarm codes:

PF1 Flashing in the display: indicates that the cabinet sensor is defective.

The cabinet will strive to keep the set temperature until it has been repaired.

Defrosting

The cabinet defrosts automatically with pre-set intervals. If the door to the cabinet is opened or the contents of the cabinet is changed frequently it may become necessary to defrost the cabinet manually.



Pressing this key continuously for more than 3 seconds will start a manual defrosting and then return to normal operation.

Defrosted water runs to a container placed in the compressor compartment and evaporates.

Maintenance and cleaning

Switch the cooler off at the socket.

The cabinet must be periodically cleaned. Clean the external and internal surfaces of the cabinet with a light soap solution and subsequently wipe dry. External surfaces can be maintained using steel oil.

Do NOT use cleansers containing chlorine or other harsh cleansers, as these can damage the stainless steel surfaces and the internal cooling system.

Clean the condenser and the compressor compartment using a vacuum cleaner and a stiff brush.

Do NOT hose the compressor compartment with water as this can cause short circuits and damage on the electrical parts.

Service

The cooling system is a hermetically sealed system and does not require supervision, only cleaning.

If the cabinet fails to cool, check if the reason is a power cut.

If you cannot locate the reason to the failure of the cabinet, please contact your supplier. Please inform model and serial number of the cabinet. You can find this information on the rating label which is placed inside the cabinet in the top right hand side.

Disposal

Disposal of the cabinet must take place in an environmentally correct way. Please note existing regulation on disposal. There may be special requirements and conditions which must be observed.



Side SA910

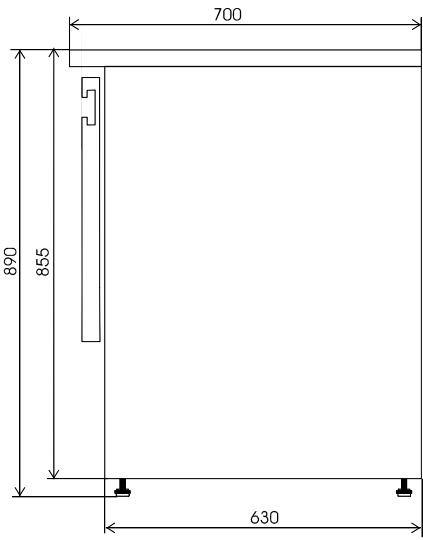

Front SA910

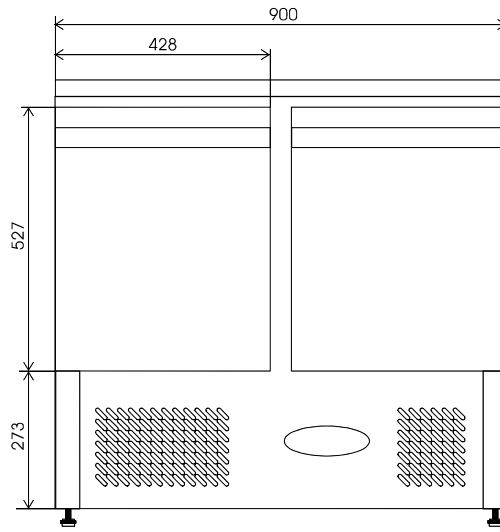

Side SA920

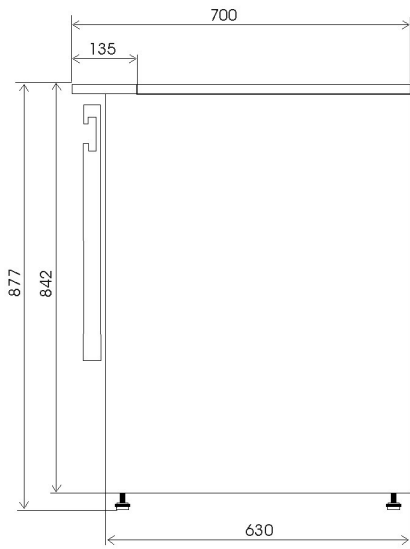

Front SA920

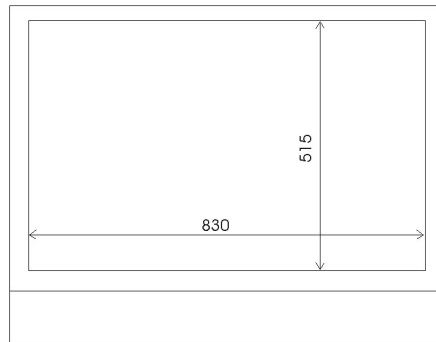
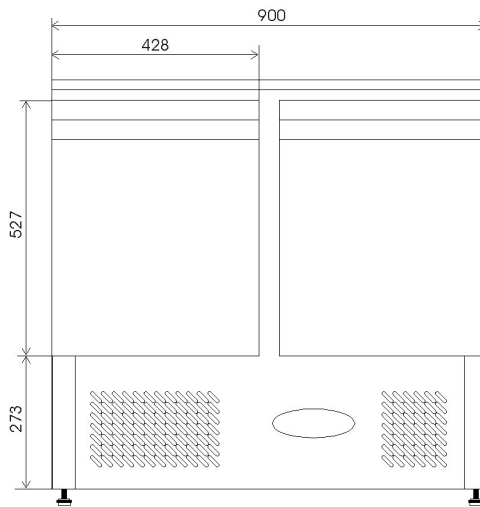

Side SA1045

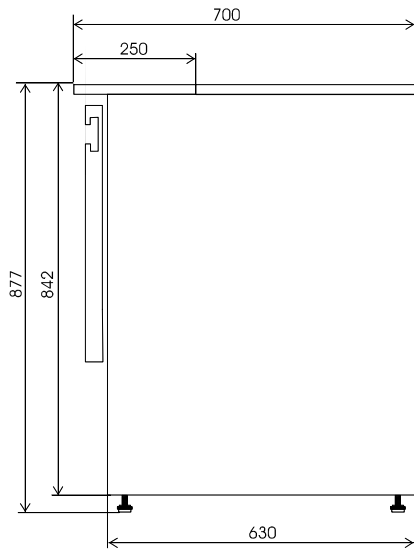

Front SA1045

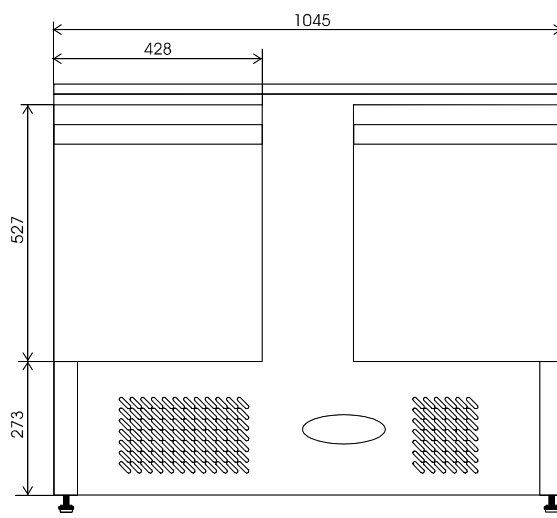

Side SA1365

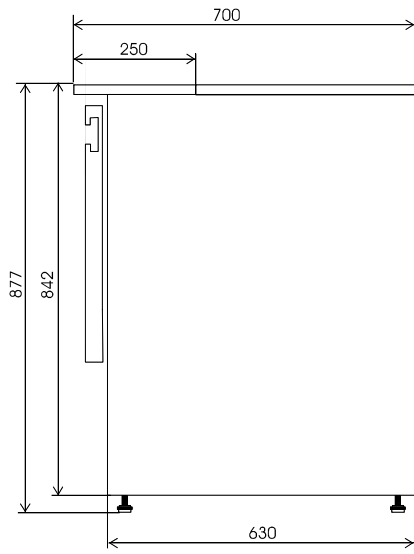

Front SA1365

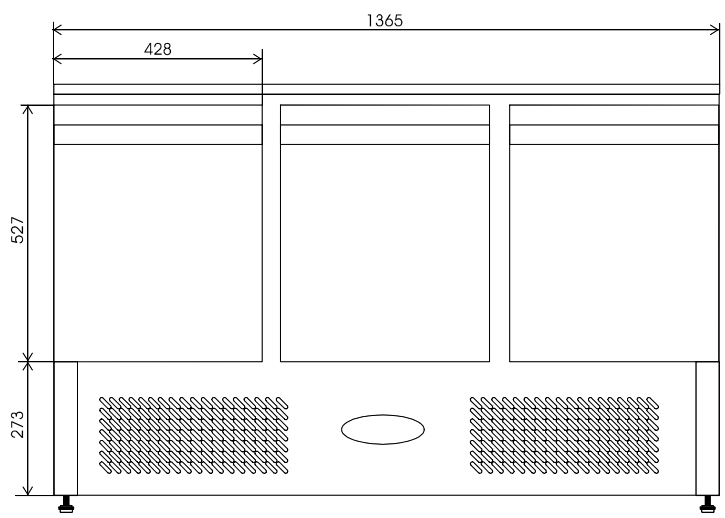

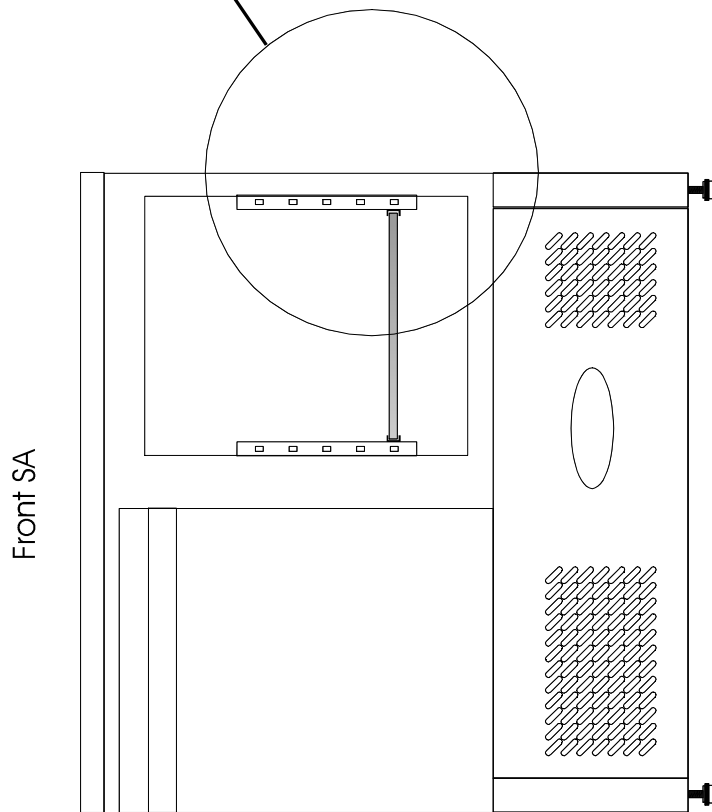
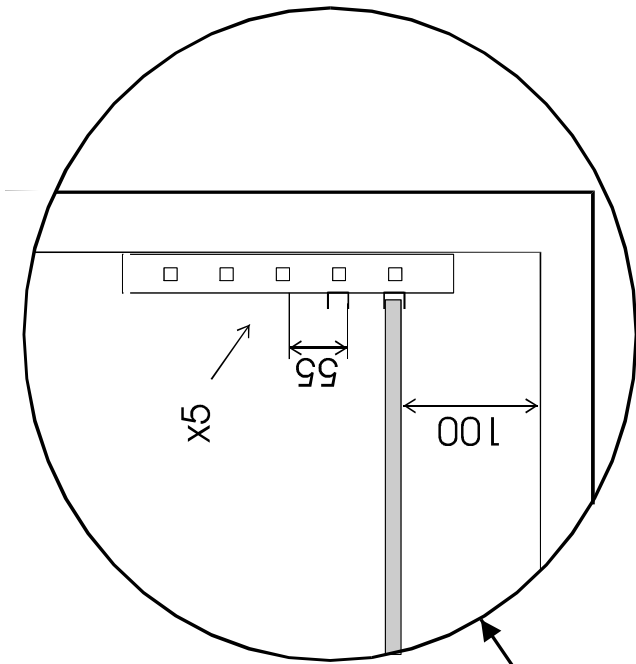

Technical data

Model	Volume Litres	Dimensions HxWxD mm.	Temperature °C	Weight nett Kgs.	Voltage V.	Wattage W.	Energy Consumption Kwh/24h
SA910	260	850x900x700	+2/+10	72	220-240	340	3,2
SA920	260	850x900x700	+2/+10	70	220-240	340	3,2
SA1045	270	850x1045x700	+2/+10	74	220-240	340	3,2
SA1365	400	850x1365x700	+2/+10	107	220-240	340	3,2
SA1365GC	400	850x1365x700	+2/+10	117	220-240	340	3,2

REK37

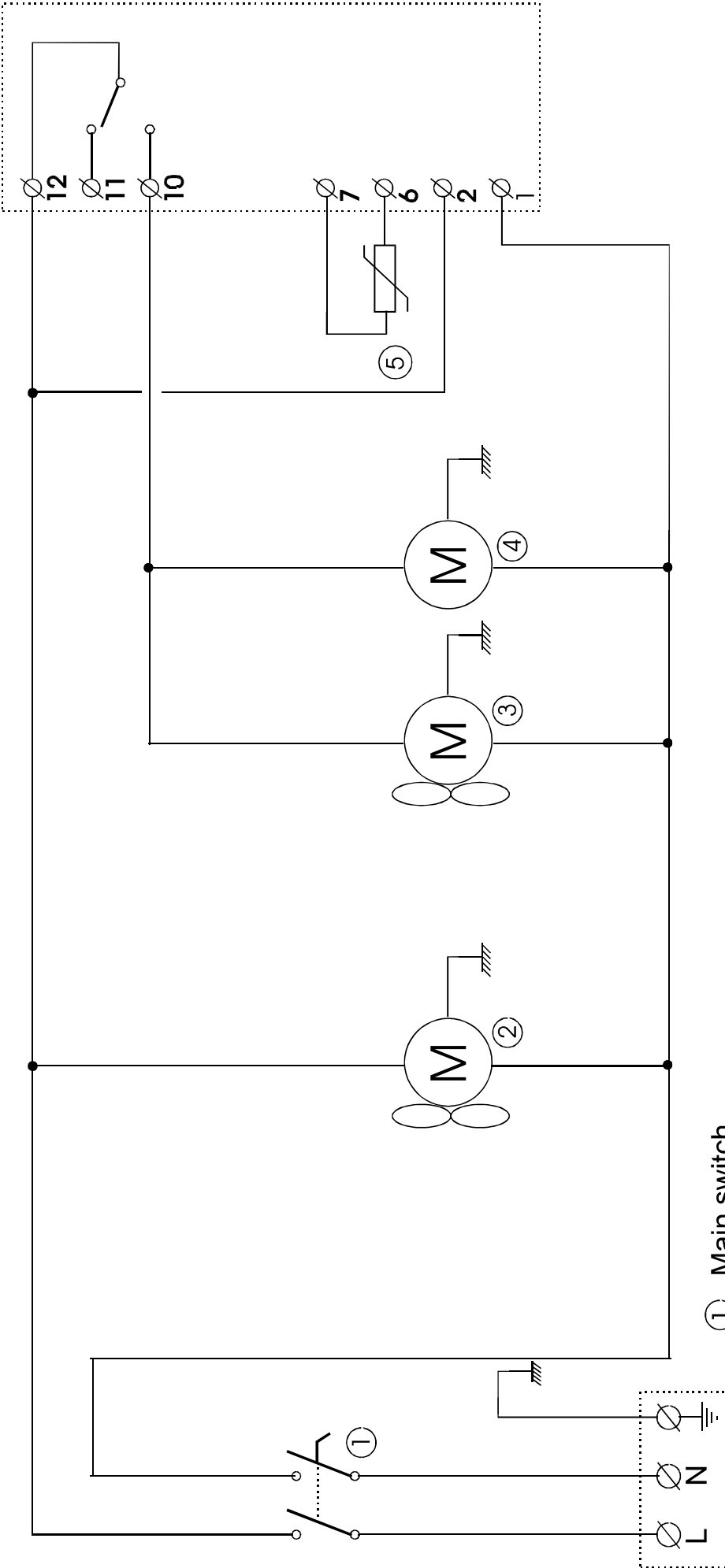

① Main switch

② Circulation fan

③ Condenser fan

④ Compressor

⑤ Cabinet probe

Fan assisted cooling
Electrical system
302-060928

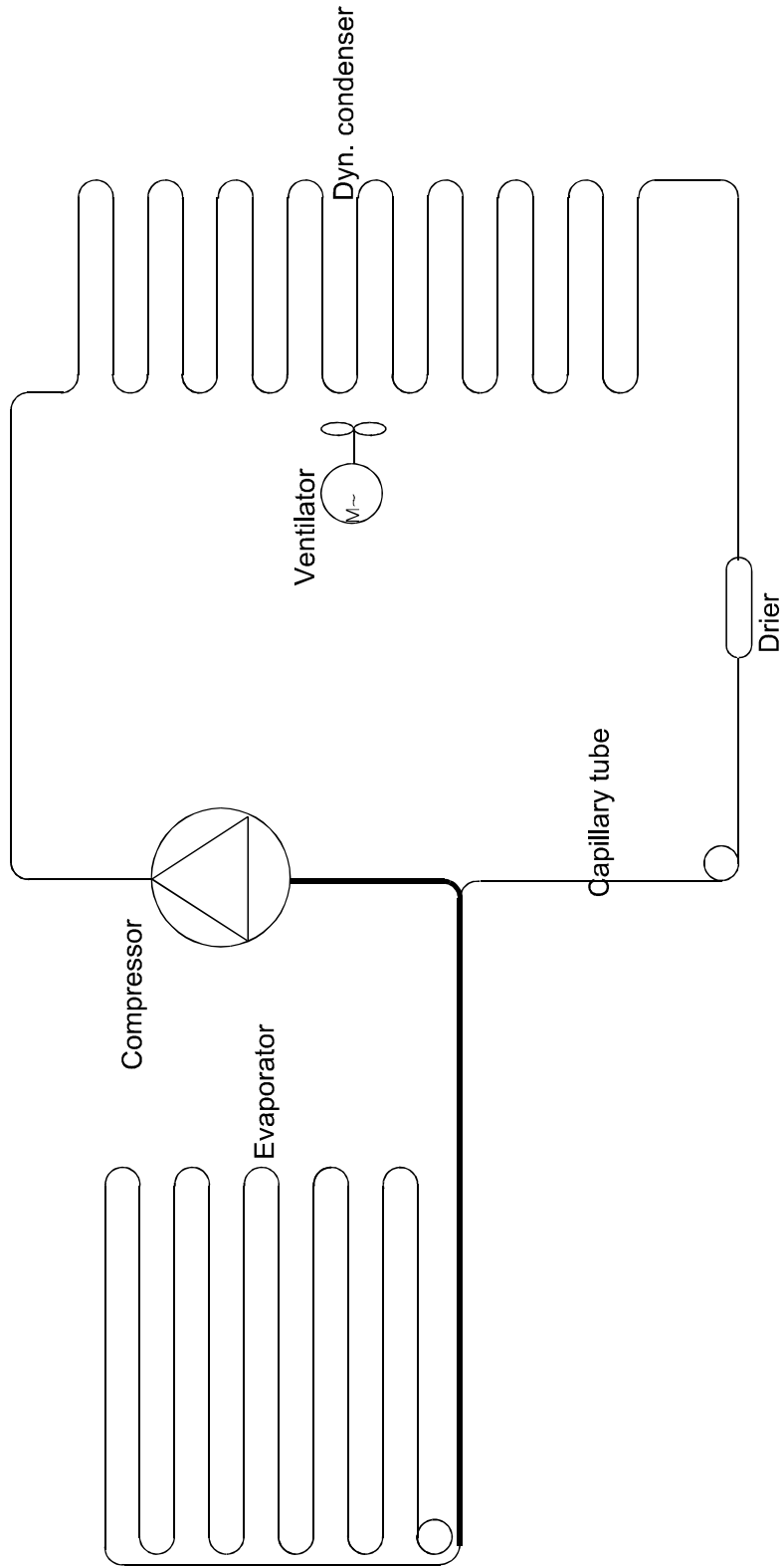

Fan assisted cooling
Refrigeration system
301-060928

REK31E

Parameter	Description	REK31
d1	Main Set point	2 °C
d2	Differential (hysteresis)	3 °C
d3	lower limit of main set point	2 °C
d4	Upper limit of main set point	10 °C
d5	Minimum time interval between the disactivation and successive activation on compressor	99sec.
d6	Max temperature alarm differential	50 °C
d7	Maximum or minimum temperature alarm delay	0
d8	Time interval between defrost cycle	6h
d9	Max defrost cycle time	20min
d12	Real temperature display delay at defrost end	30 min
d14	Dripping time	1min
d19	Offset ?	-4 °C
d22	Unit of measure, 0=C, 1=F	0
d23	Compressor function during o probe failure	2
d24	Compressor on-time during probe failure	10 min
d25	Compressor off-time during by probe failure	10 min
d38	Minimum temperature alarm differential	40 °C