

01/2010

Mod:TPG2-12

Production code:TP12/JG



Diamond
catering equipment

1. INSTALLATION

Before installation and operation of the appliance, the following must be observed.

For EU und CH (Switzerland) applies:

The appliance must be connected and operated according to national regulations. This applies for installation, air circulation of the room and exhaustion of combustion products.

Only for CH (Switzerland) applies:

- SVGW norms for gas G1 (2002): Installations for gas
- EKAS directories no. 1942 for liquid gas
- Prescriptions from instances of the cantons (for ex. fire police)

For DE (Germany) applies:

The appliance must be connected according existing installation regulations. It may only be operated in a room with sufficient air circulation to avoid formation of unhealthy combustion products.

The following regulations, technical rules and regulations are compulsory for installation and operation of the appliance:

- Building regulations of the countries
- Fire regulations of the countries
- Regulations working premises
- Building regulations fire technical requirements and air circulation
- DVGW - Instruction G 600 (TRGI), „Technical rules for gas installations“
- TRF „Technical rules liquid gas“
- DVGW – Instruction G 634 „Installation commercial kitchens, gas operating installations“
- Accident regulations VBG 21
- Accident regulations VBG 77
- Security rules kitchens ZH 1/37
- Directions „Air technical installation kitchens“ VDI 2052
- Regulations energy supply installations (GVU)

1.1 Directions

For the installation and adjustment of the appliances as well as for the changes of the gas types, an authorized technician must be called. Sealed parts by the producer or authorized agent may not be touched by the technician. During operation the appliance must be supervised.

1.2 Place of Installation / Setting Appliance

The appliance must be placed on a stable solid platform. The platform must be flat and horizontal. When placed on a table, this must be of non-combustable material.

If the appliance on the wallside is connected with flexible tubes, then the appliance must be screwed to the platform.

This fixation is a must for the Table Models.

If the appliance is placed near temperature sensitive parts (f.i. furniture, electric cables in the wall) there has to be a distance of 100 mm to the rear wall and 200 mm to the side walls.

1.3 Gas connection

Before connecting the appliance, control if the gas type corresponds to the gas type of the place of installation.

If this is not the case an adjustmanet must be made before starting up the appliance.

If flexible tubes are used, these tubes must be in DIN 3384. (Depending of the countries, those which are allowed)

In the gas inlet there must be a gas stop cock, fixed in a suitable position.

Depending on national requirements, a thermo stop cock must be installed before the appliance.

After connection, all gas pipes must be checked with foam or leak sprays under pressure for identifying gas leaks.

2. Technical Data (valid only for DE / CH / AT)

The appliance is suitable for operation of earth- or liquid gas

Category II 2 ELL 3 B/P (DE)

II 2 H 3 B/P (AT/CH)

	call pressure	allowed connection pressure Ranges
Earth gas	20,0 mbar	18,0 - 25,0 mbar
Liquid gas	50,0 mbar	42,5 - 57,5 mbar

Outside this range the appliance may not be operated.

2.1. Technical Data (valid for EU)

The appliance is suitable for operation of earth- or liquid gas / Construction A1

Category II 2 ELL 3 B/P

Countries	Category	connection pressure (mbar)	
		2. family Earthgas	3. family Liquid gas
AT	II2H3B/P	20	50
BE	II2E+3+	20/25	28-30/37
CH	II2H3B/P	20	50
DE	II2ELL3B/P	20	50
DK	II2H3B/P	20	28-30
ES	II2H3+	20	28-30/37
FI	II2H3B/P	20	28-30
FR	II2E+3+	20/25	28-30/37
GB	II2H3+	20	28-30/37
GR	II2H3+	20	28-30/37
IE	II2H3+	20	28-30/37
IT	II2H3+	20	28-30/37
LU	I2E	20	
NL	II2L3B/P	25	28-30
NO	I3B/P		28-30
PT	II2H3+	20	28-30/37
SE	II2H3B/P	20	28-30

2.2 Type of construction

The machines are classified in the following types of construction:

type	Type of construction
TP-JG 12/G	A1
TP-JG 15/G	B21
TP-JG 18/G	B21
TP 12/G	A1
TP 15/G	A1
TP 18/G	B21

Machines of type B 21 have to be set up under a dust marching off machine.

2.3 Heat load, gas connection values, combustion requirement, exhaust quantity

Type	Heat loader		Gas connection value			Combustion requirement	Exhaust quantity
	Full fire	Minor fire	Earth gas E	Earth gas L	Liquid gas		
			Earth gas H (G20) HuB 9,45 kWh/m ³	Earth gas LL (G 25) HuB 8,12 kWh/m ³	(G 30/G 31) HuB 12,68 kWh/kg		
TP-JG 12/G	10 kW	2,8 kW	1,06 m ³ /h	1,23 m ³ /h	0,79 kg/h	11,2 m ³ /h	12,2 m ³ /h
TP-JG 15/G	15 kW	5,6 kW	1,59 m ³ /h	1,85 m ³ /h	1,18 kg/h	16,8 m ³ /h	18,3 m ³ /h
TP-JG 18/G	15 kW	5,6 kW	1,59 m ³ /h	1,85 m ³ /h	1,18 kg/h	16,8 m ³ /h	18,3 m ³ /h
TP-12 / G	10 kW	4 kW	1,06 m ³ /h	1,23 m ³ /h	0,79 kg/h	11,2 m ³ /h	12,2 m ³ /h
TP-15 / G	10 kW	4 kW	1,06 m ³ /h	1,23 m ³ /h	0,79 kg/h	11,2 m ³ /h	12,2 m ³ /h
TP-18 / G	10 kW	4 kW	1,06 m ³ /h	1,23 m ³ /h	0,79 kg/h	11,2 m ³ /h	12,2 m ³ /h

The small combustion load is 2.8 kW for TP-JG... /G each burner and 4.0 kW for TP- /G each burner.

This results in the following **FLOW VALUES** each burner:

	TP-JG.../G	TP-.../G
Earth gas H, E (G20)	0,30 m ³ /h	0,48 m ³ /h
Earth gas L, LL (G25)	0,34 m ³ /h	0,55 m ³ /h
Liquid gas (G30)/(G31)	0,22 kg/h	0,35 kg/h

The machine is working with full fire with fixed nozzles without pre-adjustment.

For the pilot flame the small combustion quantity is regulated for liquid gas with fixed nozzles. For earthgas the nozzles are adjusted.

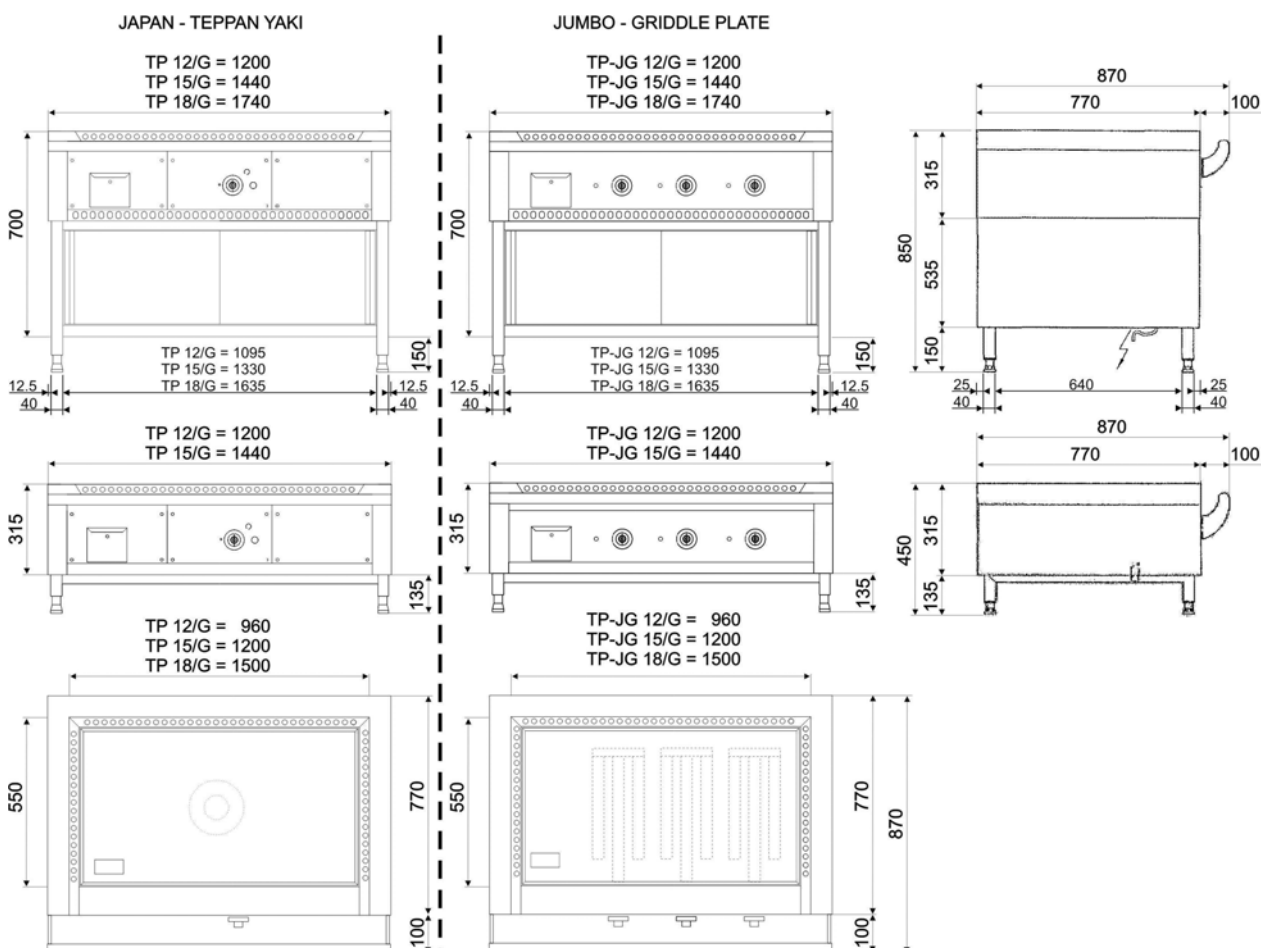

3. Instruction of Users

The user must be instructed how to operate the appliance. The instruction for use must be kept to the user. The user must be told that after construction changes in the room, which affects the combustion supply, the operation control must be carried out.

4. Operation

4.1 Operation elements

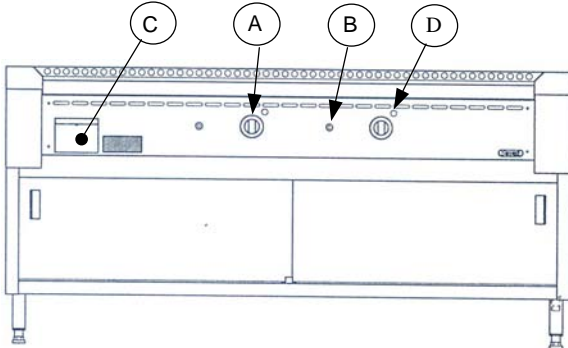





- A = Knob for burner
- B = Piezo igniter
- C = Fat collecting drawer
- D = Opening for observation of the pilot flame

4.2 Start up Burner (open cooking place)

- Before operation the main gas cock on the appliance must be opened.
- Then press the knob of the safety tap "A" and turn same anti clockwise .
- Keep the knob pressed in and ignite with ignition pistol the pilot flame..
- After pilot flame burns, knob "A" must remain pressed in for 15-20 seconds. If after releasing knob "A" the pilot flame continues burning, then the appliance is operable.
- If the pilot flame goes out, you have to repeat the ignition process.
- Now turn gas valve handle "B" anti clockwise to the required position between full combustion and small combustion.

Knobs for the open cooking places



-  "out"
-  Pilot ignition position
-  MAX. position
-  MIN. position

4.3 Closing of burner

If the burner is only temporary to be cut, the gas cock with handle must be placed clockwise into position, so that the appliance remains operable.

For longer periods of interruption, the gas cock with handle must be placed into position -  -. The main gas armature is to be closed.

5. Important Notice

The appliance is for commercial use and should be operated by qualified staff.

During operation the appliance must be attended.

It is necessary to have the appliance checked at regular intervals.

The time of checking depends on the use.

The checking must take place at least once a year.

The frying plate keeps hot long time after use. Attention of burning danger!

The fat collecting drawer(C) should be taken out the machine after complete cooling down, to avoid burning caused of hot fat.

In case of problems, the appliance must be cut off. The main gas cock must be closed and the service engineer is to be called.

An eventual change of the gas type may only be carried out by the producer or ist service agent.

6. Cleaning

The cleaning should be carried out after each use of the appliance.

Before cleaning all armatures must be placed in position -O-. The main gas cock is to be closed.

Clean with warm water, if required some detergent, non aggressive cleaner.

A strongly dirty plate can be pre cleaned with a scraper.

For cleaning do not use steel wool or scraper, since corrosion could occur also on stainless steel.

The frying plate should be rubbed with a oil soaked cloth, to avoid corrosion.

⇒ **Attention! Don't clean the range with high pressure water**

The range will be have **more long use life** and smooth work, if you have **regular clean** every day.

7. Service

The appliance requires a regular service. We recommend a service contract.

Service and repairs may only be carried out by the producer or service agent with qualified staff.

For Service and repairs **only original parts** should be used.

During Service, security arrangements of the appliance, function of burners and operation of burning operation is to be checked. It is to control that no lift off or back stroke of the burners in hot condition occurs.

All gas pipes and parts must be controlled for closeness. Slits of the burners and nozzles in the primary air segment must be free of foreign debris.

The gas armatures must be checked for easy of operation. In case of heavy movements, requires the exchange of these parts. Application of grease, in exceptional cases may only be done by the service engineer. Sealed parts of the producer may not be touched by the service engineer. If apart from the listed works other repairs should be required, same should be done.

Only proper handling of the appliance, regular service by service technicians, guarantees problem free function of the appliance with operation security.

This is also in view of legal regulations for technical equipment as well as accident regulations.

8. Behaviour in disturbances

Disturbances can occur due to mistakes in the gas supply, dirtiness of functioning parts, wrong handling or failing ignition, regulators, function of control parts.

If the gas supply is ok., all functioning parts clean, wrong handling excluded, you have to call a service engineer.

In case of disturbances the gas armature (main gas cock) must be closed.

Repairs may only be carried out by qualified service engineers under consideration of ruling regulations for operation and installation.

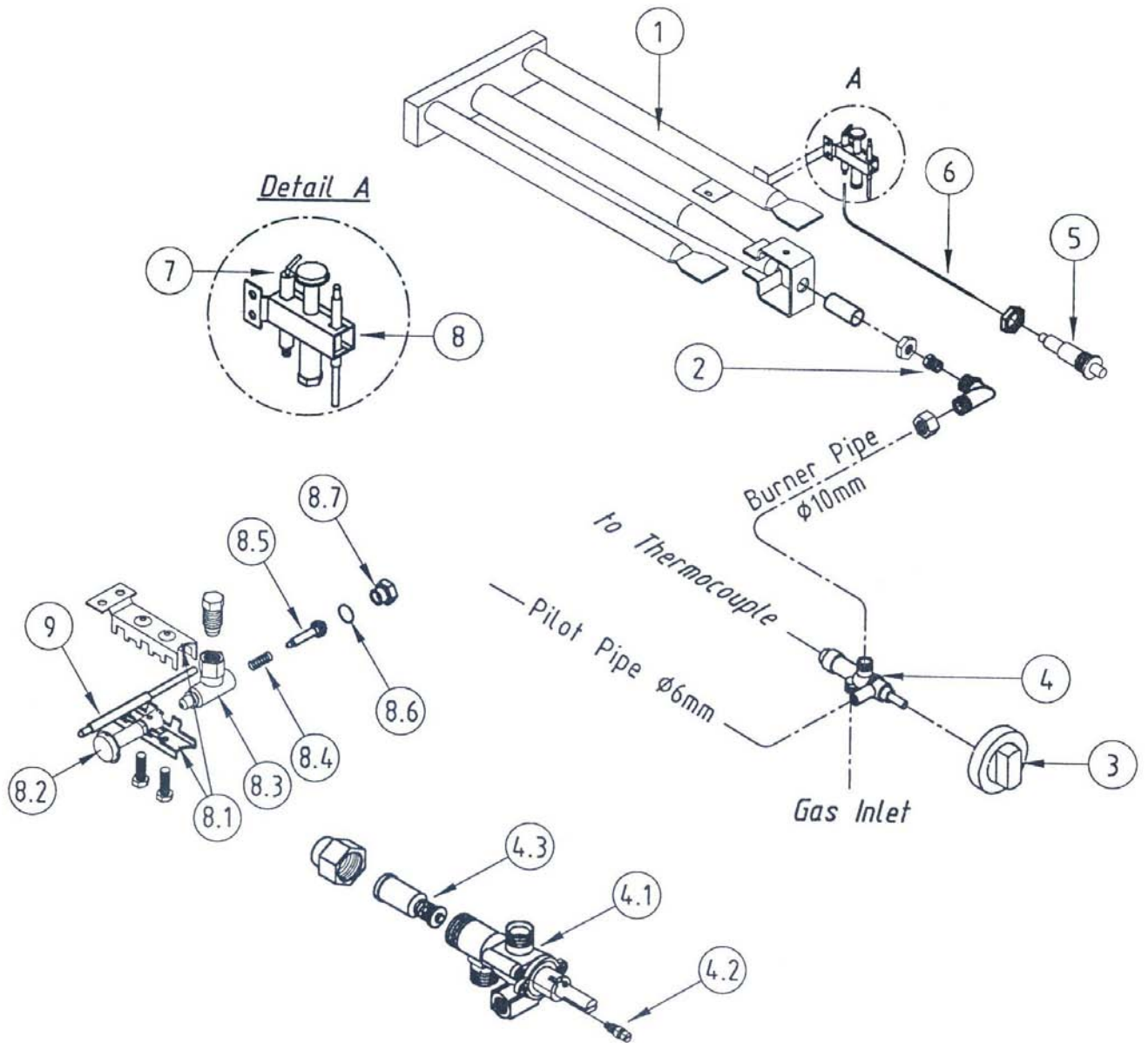

Spare parts list types TP-JG ... / G

NO°	DESCRIPTION	P/N	QTY	
			TP-JG 12 / G	TP-JG 15 / G TP-JG 18 / G
1	Burner	GS 3648	2	3
2	Injector Ø 1,0 (Propangas 50mbar) Injector Ø 1,65 (Earthgas 20mbar)	GS 3835	2	3
3	ABS knob	GS 3602	2	3
4	Security tab	GS 3875	2	3
4.1	Security tab	GS 3875	2	3
4.2	By pass screw Ø 0.95 mm (small flame)	GS 3687	2	3
4.3	Magnet for security Ø 10,5mm	GS 8036 P	2	3
5	Piezzo igniter	GS 3863	2	3
6	Spark plug cable 600 mm	GS 3682	2	3
7	Spark plug	GS 3856	2	3
8	Pilot burner DBL	GS 3851	2	3
8.1	Pilot bracket	GS 8042 P	2	3
8.2	Pilot head	GS 8041 P	2	3
8.3	Pilot body	GS 8040	2	3
8.4	Spring for pilot	GS 8039	2	3
8.5	Nozzle for pilot	GS 3828	2	3
8.6	Seal for pilot	GS 8038 P	2	3
8.7	Taking off screw for pilot	GS 8037 P	2	3
9	Thermocouple M9 x 1/600 mm	GS 3895	2	3

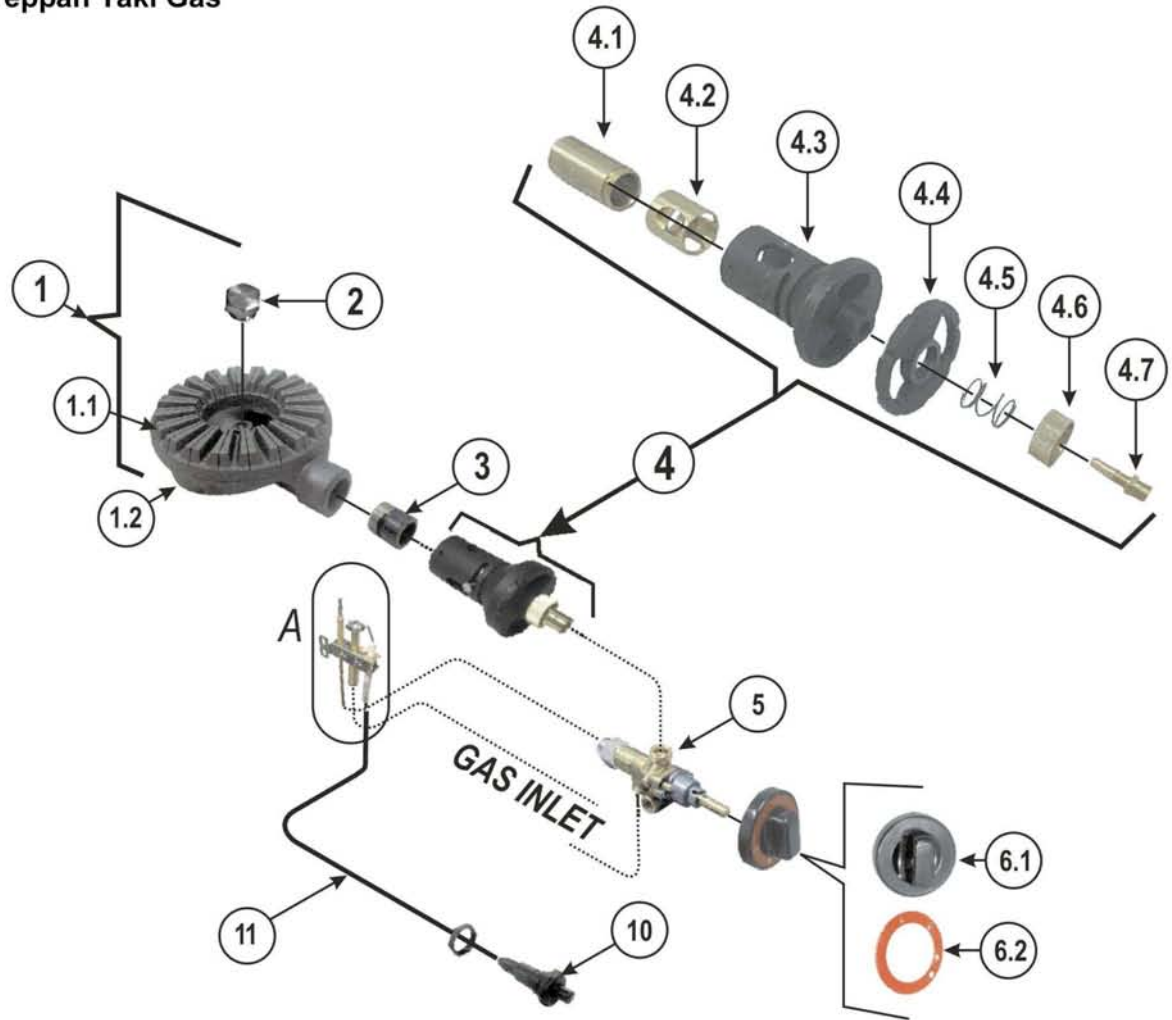

Detail A

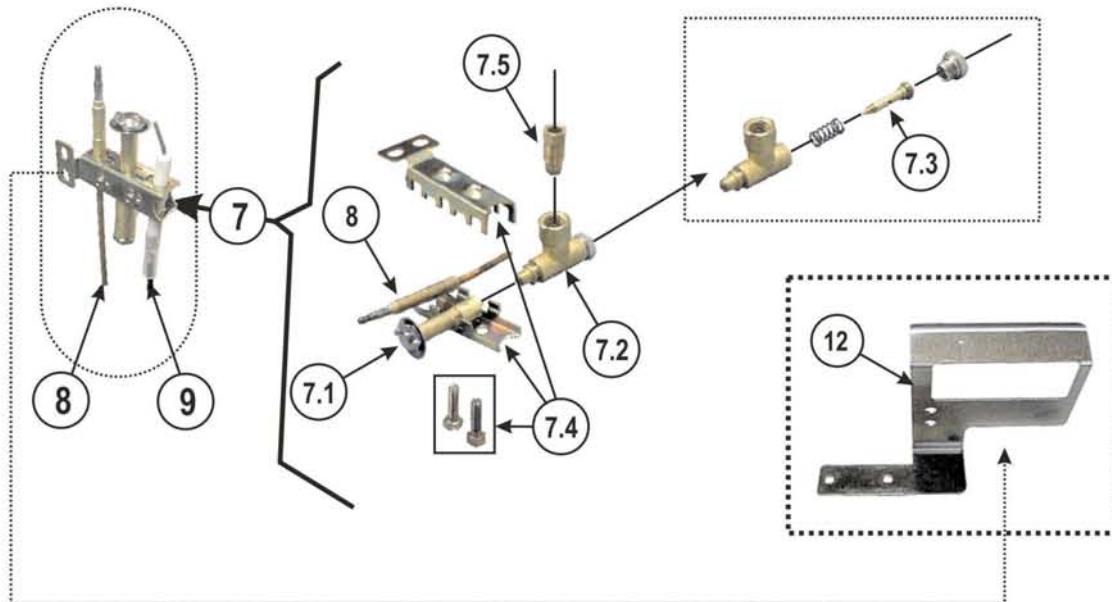

NO°	DESCRIPTION	P/N	QTY	
			TP 12 / G TP 15 / G TP 18 / G	
1	Burner set	NS 9001	GS 8020 S	1
1.1	Burner head	NS 9001	GS 4030	1
1.2	Burner base	NS 9001	GS 4023	1
2	Plug 3/8" x 1/4" for burner		GS 4232	1
3	Pipe to burner base	NS 9001	SP 8903	1
4	Primary air control assy complete with Venturi		GS 8000 S	1
4.1	Inside pipe to air chamber		GS 2826	1
4.2	Air chamber bush - inside		GS 2825	1
4.3	Case of primary air mixing chamber		GS 4357	1
4.4	Air mixing chamber plate - outside		GS 4358	1
4.5	Spring for primary control assy		GS 1456	1
4.6	Fixing bush for primary air control assy 1 ¼"		GS 2851	1
4.7	Nozzle Ø 1,4 mm (Propangas 50mbar) Nozzle Ø 2.5 mm (Earthgas 20mbar)		GS 282 C GS 282 J	1
5	Safety Gas Cock		GS 3875	1
6.1	ABS Knob for gas valve		GS 3602	1
6.2	Label Ring for gas knob		GS 3862	1
7	Pilot burner DBL		GS 3851	1
7.1	Pilot haed (3 flames)		SP 385A	1
7.2	Pilot body with taking off screw & fixing spring for nozzle		SP 385B	1
7.3	Nozzle for pilot burner DBL - 0.20mm (LPN) 0.35mm (LNG)		SP 385F SP 385C	1 1
7.4	Pilot bracket (3 pieces-bracket) with fixing screw		SP 385D	1
7.5	Pilot – fixing screw 6mm for gaspipe		SP 385E	1
8	Thermocouple M9x1/1000mm		GS 3890	1
9	Ignition plug		GS 3856	1
10	Piezo Igniter		GS 3720	1
11	Cable for ignition plug 600mm (2,8Ø0,6mm)		GS 3682	1
12	Support and cover for pilot burner TP		SP 9602	1

TROUBLE SHOOTING

N°	TROUBLE	CAUSE	CHECK / REPAIR
1	The igniter does not function	<ul style="list-style-type: none"> - The cable of igniter is disconnected - The igniter is damaged 	<ul style="list-style-type: none"> - Check and repair - Change (call a technician)
2	The pilot burner does not light	<ul style="list-style-type: none"> - Gas runs out - The gas line to pilot burner is closed - The hole of nozzle Tipp of pilot burner is closed 	<ul style="list-style-type: none"> - Check and fill gas - Check and clean
3	The burner flame is yellow	<ul style="list-style-type: none"> - The primary air adjuster is closed - The burner is dirty 	<ul style="list-style-type: none"> - Check and open the primary air adjuster - Clean with brush
4	The burner does not light	<ul style="list-style-type: none"> - The gas cock is damaged 	<ul style="list-style-type: none"> - Check and change
5	The pilot flame lights but it extinguishes again	<ul style="list-style-type: none"> - The thermocouple is slacked - The thermocouple does not produce voltage (mv) - The thermocouple is dirty 	<ul style="list-style-type: none"> - Check and tight - Check with Milivoltmeter, if the thermocouple is damaged, change it - Check and clean

9. Gas conversion

The gas conversion may only be carried out by a qualified service engineer authorized by the producer.

Before conversion, you have to know the gas conditions (type, gas pressure).

9.1 Technical DATA (valid only for DE / CH / AT)

The appliance is for operation of earth- or liquid gas

Category: II 2 ELL 3 B/P (für DE)
II 2 H 3 B/P (für AT/CH)

	Call pressure	Allowed connection pressure ranges
Earth gas	20,0 mbar	18,0 - 25,0 mbar
Liquid gas	50,0 mbar	42,5 - 57,5 mbar

Beyond these pressure ranges the appliance may not be operated!

9.2 Technical data (valid for EU)

The appliance is for operation of earth- or liquid gas / Construction A1

Country of destination	Category	Pressure ranges (mbar)	
		2. family Earth gas	3. family Liquid gas
AT	I12H3B/P	20	50
BE	I12E+3+	20/25	28-30/37
CH	I12H3B/P	20	50
DE	I12ELL3B/P	20	50
DK	I12H3B/P	20	28-30
ES	I12H3+	20	28-30/37
FI	I12H3B/P	20	28-30
FR	I12E+3+	20/25	28-30/37
GB	I12H3+	20	28-30/37
GR	I12H3+	20	28-30/37
IE	I12H3+	20	28-30/37
IT	I12H3+	20	28-30/37
LU	I2E	20	
NL	I12L3B/P	25	28-30
NO	I3B/P		28-30
PT	I12H3+	20	28-30/37
SE	I12H3B/P	20	28-30

9.3. Heat load, Gas connection values

Obtain the heat load.

The appliance is operated in full combustion with fixed nozzles without prior adjustment.

For the main burner and pilot flame, small combustion for liquid gas is obtained with fixed nozzle, for earth gas the nozzle has to be regulated.

Type	Heat load		Gas connection values		
	Full fire	Minor fire	Earth gas E Earth gas H (G20)	Earth gas L Earth gas LL (G 25)	Liquid gas (G 30/G 31)
			HuB 9,45 kWh/m ³	HuB 8,12 kWh/m ³	HuB 12,68 kWh/kg
TP-JG-12/G	10 kW	2,8 kW	1,06 m ³ /h	1,23 m ³ /h	0,79 kg/h
TP-JG-15/G	15 kW	5,6 kW	1,59 m ³ /h	1,85 m ³ /h	1,18 kg/h
TP-JG-18/G	15 kW	5,6 kW	1,59 m ³ /h	1,85 m ³ /h	1,18 kg/h
TP-12 / G	10 kW	4 kW	1,06 m ³ /h	1,23 m ³ /h	0,79 kg/h
TP-15 / G	10 kW	4 kW	1,06 m ³ /h	1,23 m ³ /h	0,79 kg/h
TP-18 / G	10 kW	4 kW	1,06 m ³ /h	1,23 m ³ /h	0,79 kg/h

The small combustion load is 2.8 kW for TP-JG... /G each burner and 4.0 kW for TP- /G each burner.

This results in the following **FLOW VALUES** each burner:

	TP-JG.../G	TP-.../G
Earth gas H, E (G20)	0,30 m ³ /h	0,42 m ³ /h
Earth gas L, LL (G25)	0,34 m ³ /h	0,49 m ³ /h
Liquid gas (G30)(G31)	0,22 kg/h	0,32 kg/h

The appliance is operated in full combustion with fixed nozzles without prior adjustment.

For the main burner and pilot flame, small combustion for liquid gas is obtained with fixed nozzle, for earth gas the nozzle has to be regulated

9.4 Nozzle list

Type of gas	Pressure (mbar)	type TP-JG.../G		type TP-.../G		burner
		Full combustion	Minor combustion	Full combustion	Minor combustion	
Earth gas H,E G20	20	Ø 1,65 mm	regulated	Ø 2,30 mm	regulated	regulated
Earth gas H,E G20	20/25	Ø 1,65 mm	regulated	Ø 2,30 mm	regulated	regulated
Earth gas LL G25	20	Ø 1,80 mm	regulated t	Ø 2,40 mm	regulated	regulated
Earth gas L G25	25	Ø 1,65 mm	regulated t	Ø 2,30 mm	regulated	regulated
Liquid gas G30/31	50	Ø 1,00 mm	Ø 0,90 mm	Ø 1,25 mm	Ø 0,90 mm	Ø 0,20 mm
Liquid gas G30/31	28-30	Ø 1,13 mm	Ø 0,95 mm	Ø 1,50 mm	Ø 1,00 mm	Ø 0,20 mm
Liquid gas G30/31	28-30/37	Ø 1,13 mm	Ø 0,95 mm	Ø 1,50 mm	Ø 1,00 mm	Ø 0,20 mm

9.5. Nozzle change

Types TP... / G: In case of change of the pilot flame nozzle as well as adjustment of the burner flame; the frying plate should be taken off the machine.

For that the frying plate should be completely cooled down.

Attention: The frying plate is heavy!

9.5.1. Nozzle change type TP ... /G

Lift frying plate. Remove fixing screw (1). Lift burner (2) abt. 10 mm and pull away from the mixing chamber (3). Remove then the complete mixing chamber (3) by turning same anti-clockwise from the nozzle. Turn the pressure ring (4) from the nozzle. Pay attention that the built in pressure ring is not lost. Remove the nozzle from the nozzle carrier and replace a new nozzle according the nozzle table for use in the country of operation and gas type required.

The nozzle must be fixed with a non-hardening sealing tape. Then replace the burner by following instructions in the opposite direction. Pay attention also to "primary air adjustment". We recommend to check the pilot flame and nozzles before rebuilding.

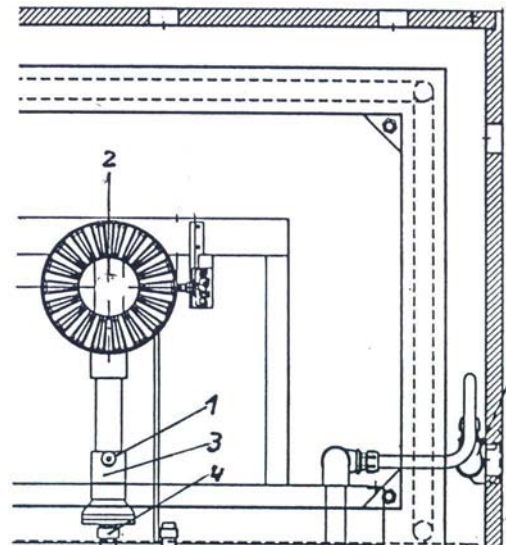

9.5.2 Nozzle change type TP-JG ... / G

Take out the fat collecting drawer and take off the ABS knob. Remove the nozzle from the nozzle carrier and replace a new nozzle according the nozzle table for use in the country of operation and gas type required. The nozzle must be fixed with a non-hardening sealing tape.

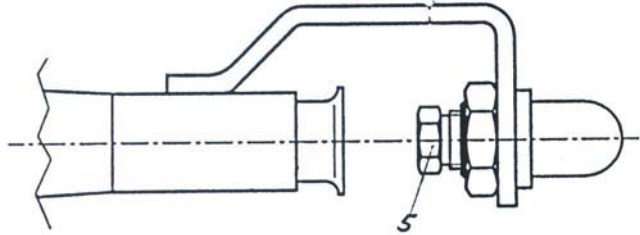

10. Small combustion adjustment

For the Combi Wok burner (soup burner) the small combustion adjustment must be regulated to 4,5 kW for earthgas.

The nozzle bore in the small combustion nozzle is 50 mbar and 30 mbar. To regulate for earthgas proceed as follows:

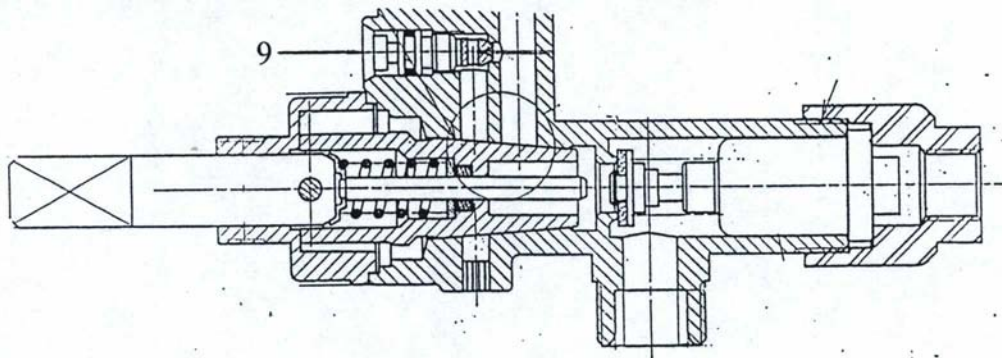

Operate burner in small combustion.

Turn off handle of the security control knob.

With a small screw driver adjust small combustion nozzle (9) that 4 kW are obtained.

(Turn **Clockwise reduces** warmth load, turn **anti clockwise increases** warmth load).

The adjustment of the warmth load can be done according volume method, see flow chart.

The adjustment of the warmth load must be such that the burner in hot or cold, ignites properly.

For changing to liquid gas the small combustion nozzle (9) turn slightly against the stroke.

11. Pilot flame adjustment

The Pilot flame must be regulated for earthgas. This is done as follows:
Pilot flame ignite covering screw (10) with washer (11). Remove with small screw driver, nozzle (C) adjust that main burner ignites well. Turn **Uclockwise reduce** gas flow, **anti clockwise increases** gas quantity.

When operated with liquid gas, nozzle (C) turn clockwise towards stroke.
After regulating washer (11) and covering screw (10) fix gas tight.

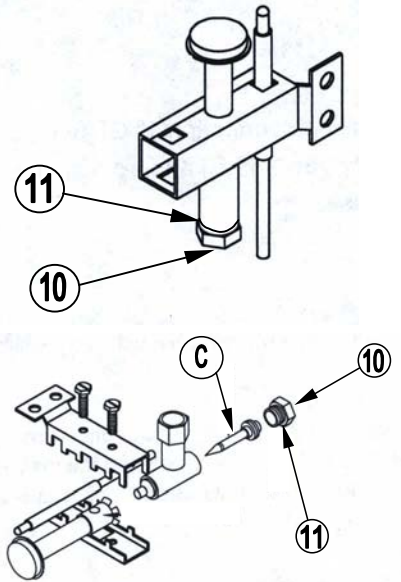

12. Primary air adjustment

The primary air is fixed and sealed by the producer according to the country of use and the gas type required. The adjustment is mentioned on the packing and the type shield.

If a gas change must be undertaken, the primary gas adjustment must follow the table below:

Type			Earth gas E(H) 20mbar	Earth gas L (LL) 20 mbar	Earth gas L 25 mbar	Liquid gas 28-30/37 mbar	Liquid gas 50 mbar
TP-JG.../G		(H) =	14 mm	14 mm	14 mm	16 mm	14 mm
TP.../G	Nut Injector	(B) =	15 mm	15 mm	15 mm	15 mm	15 mm
		(A) =	closed	closed	closed	closed	closed

Primary air adjustment types TP-JG ... / G

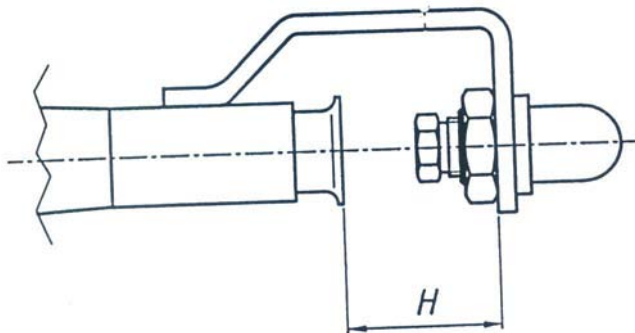

Primary air adjustment types TP ... / G

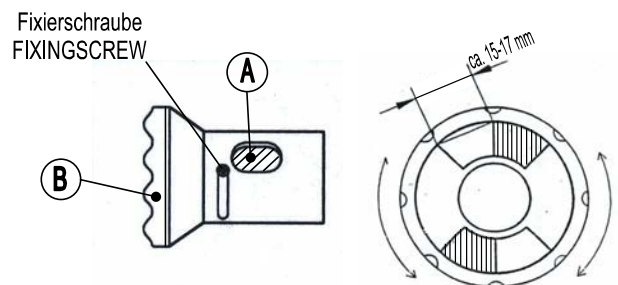

13. Tests

After a conversion the following requirements must be fulfilled:

- Nozzle diameter and pressure must be identical to the indication of the producer
- The tightness of all gas pipes and parts must be secure
- Ignition, through ignition, over ignition must be guaranteed for full combustion and small combustion operation
- The flame may not lift off nor beat back to the nozzles
- All burners, ignition and control arrangements must be checked for dirt, secureness and function
- The closing time of the thermo electric ignition control **may not exceed 60 seconds**

14. Sticker

After a conversion of a gas type has been carried out a new sticker must be placed on the appliance which shows clearly the new gas type and gas pressure.

TROUBLE SHOOTING

N°	TROUBLE	CAUSE	CHECK / REPAIR
1	The igniter does not function	<ul style="list-style-type: none"> - The cable of igniter is disconnected - The igniter is damaged 	<ul style="list-style-type: none"> - Check and repair - change (call a technician)
2	The pilot burner does not light	<ul style="list-style-type: none"> - Gas runs out - The gas line to pilot burner is closed - The hole of nozzle Tipp of pilot burner is closed 	<ul style="list-style-type: none"> - Check and fill gas - Check and clean
3	The burner flame is yellow	<ul style="list-style-type: none"> - The primary air adjuster is closed - The burner is dirty 	<ul style="list-style-type: none"> - Check and open the primary air adjuster - Clean with brush
4	The burner does not light	<ul style="list-style-type: none"> - The gas cock is damaged 	<ul style="list-style-type: none"> - Check and change
5	The pilot flame lights but it extinguishes again	<ul style="list-style-type: none"> - The thermocouple is slacked - The thermocouple does not produce voltage (mv) - The thermocouple is dirty 	<ul style="list-style-type: none"> - Check and tight - Check with Milivoltmeter, if the thermocouple is damaged, change it - Check and clean