

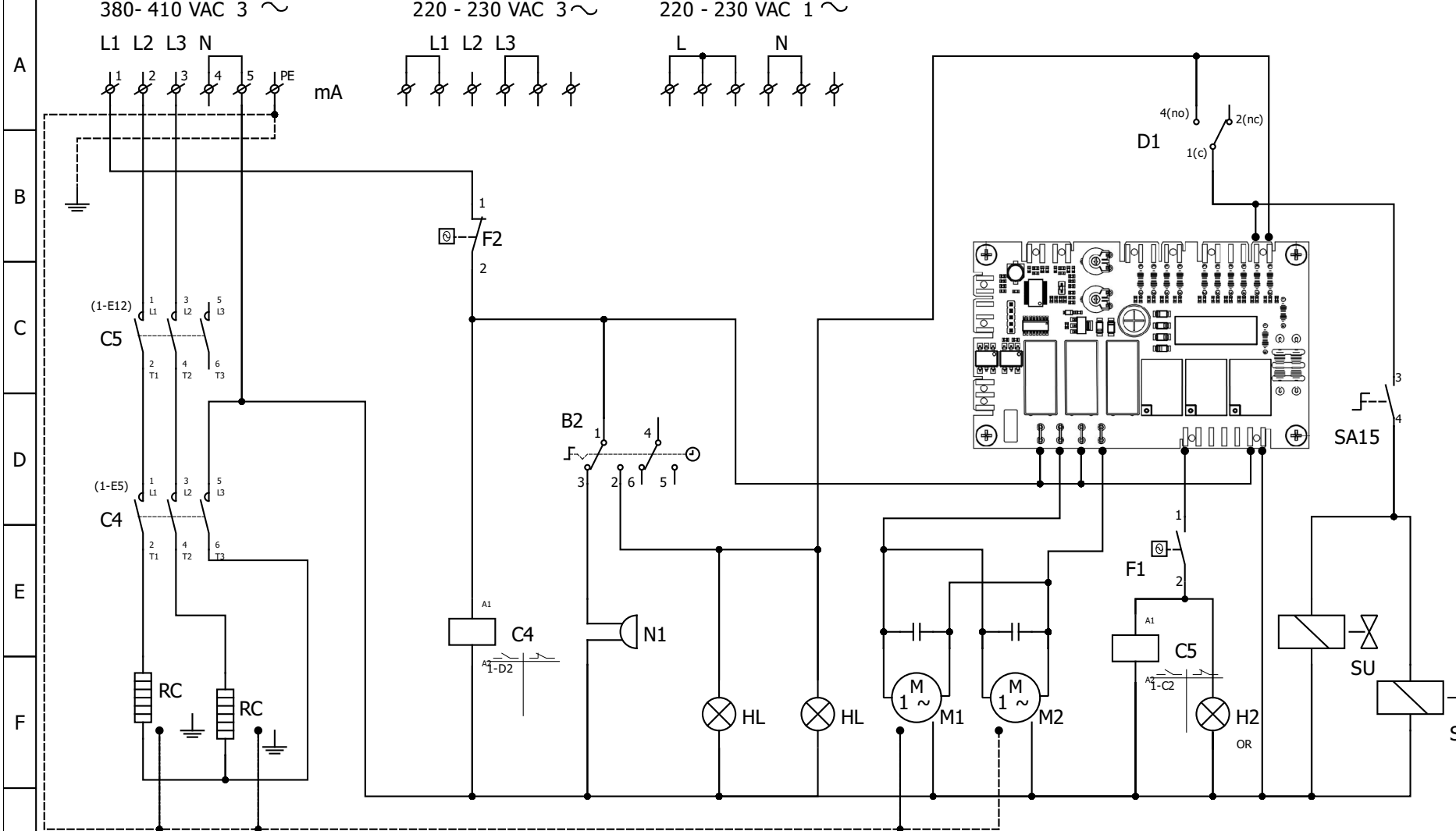

**MOD : CPE644-E**

**Production code : P011205DIA**

**12/2023**



| SIG | ENGLISH DESCRIPTION                    |
|-----|--|
| B15 | WATER INJECTION BUTTON COOKING CHAMBER |
| B18 | SALAMANDER TIMER                       |
| B2  | COOKING TIMER                          |
| C4  | COOKING CHAMBER HEATER CONTACTOR       |
| C5  | COOKING CHAMBER HEATER CONTACTOR       |
| F1  | COOKING CHAMBER THERMOSTAT             |
| F2  | SAFETY CHAMBER THERMOSTAT              |
| H1  | OVEN PILOT LAMP ON                     |
| H2  | HEATERS LAMP ON                        |
| H5  | SALAMANDER COOKING TIMER PILOT LAMP    |
| HL  | COOKING CHAMBER LIGHT                  |
| M1  | COOKING CHAMBER MOTOR 1                |
| M2  | COOKING CHAMBER MOTOR 2                |
| mA  | MAIN TERMINAL BOARD                    |
| N1  | COOKING CYCLE END BUZZER               |
| RC  | CHAMBER HEATER ELEMENT                 |
| RS  | SALAMANDER HEATER ELEMENT              |
| SU  | HUMIDIFICATION WATER SOLENOID VALVE    |

|                     | Technical data | Models / Type |                 |                 |              |             |             |             |
|---------------------|----------------|---------------|-----------------|-----------------|--------------|-------------|-------------|-------------|
|                     |                | VO-UA-204-E   | VO-UA-104-E-21F | VO-UA-604-E-21F | VO-UA-104-E  | VO-UA-604-E | VO-UA-106-E | VO-UA-606-E |
| Power (kW)          |                | 3.3           | 3               | 3               | 6.5          | 6.5         | 7.9         | 7.9         |
| Voltage (V)         |                | 220 / 240 1N  |                 |                 | 380 / 410 3N |             |             |             |
| Nominal Current (A) |                | 14,3          | 13,5            | 13,5            | 13           | 13          | 16          | 16          |
| Frequency (Hz)      |                | 50 / 60       |                 |                 | 50 / 60      |             |             |             |

Autore : DP  
Data : 29/06/2023

FORNO 4 & 6 x 600 x 400 / 4 & 6 x GN 1/1

File : A050107  
Foglio : 1/1