

02/2021

# **Mod: CF-170/S**

**Production code: FALCON 2-70\_**

**CF-170/S**

\*

**DESCRIPTION**

The robust Falcon 2-70 vacuum packaging machine with stainless steel frame is standard equipped with a Busch vacuum pump, an aluminium lid and vacuum chamber and 2 seal bars. This double chamber complies with CE standards.

**FEATURES**

- Standard with 2 seal bars: 2 x 550mm (front-back),
- Standard double seal (two wires). Optional without extra costs: Cut-off/Wide seal
- Silicon holders easily removable for cleaning and maintenance purposes
- Pump capacity: 100 m<sup>3</sup>/h Busch vacuum pump
- Pump maintenance and cleaning program
- Machine cycle: 15-40 sec
- Standard Digital control with 10 program memory and Time control
- Comes with insert plates for a faster cycle and product adjustment
- Stainless steel frame
- Aluminium chamber and lid with sight glass

**OPTIONS**

- 1-2 Cut-off seal
- Bi-active seal
- Soft Air
- Sensor control, Advanced Control System (ACS)
- Liquid control
- Gas flush

**ACCESSORIES**

- Zebra ZD410 thermal label printer (only in combination with ACS)
- Inclined insert plate (for packing liquids)
- Service kit for standard maintenance

# CF-170/S- SPECS

# VACUUM PACKAGING MACHINE - SPEC SHEET

## DIMENSIONS

In mm

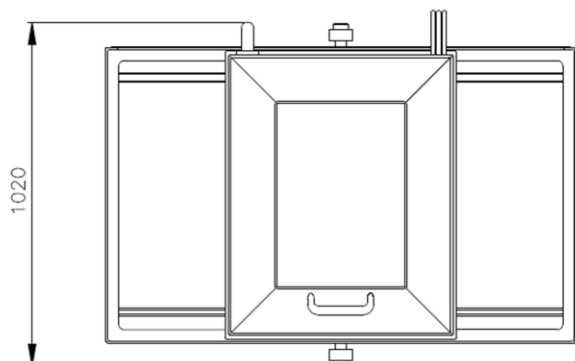

OUTER DIMENSIONS

Falcon 2-70

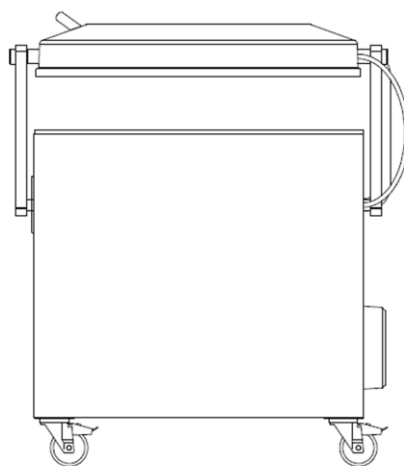
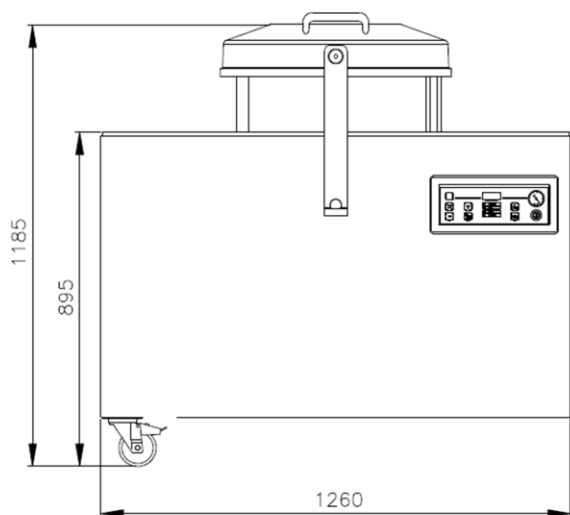

Model	Dimensions (mm)		Voltage* (Hz)	Pump capacity (m <sup>3</sup> /h)	Power (kW)	Weight (kg)
	Chamber (usable space) L x W x H	Machine L x W x H				
Falcon 2-70	700 x 550 x 235	1020 x 1260 x 1185	400V-3-50	100	3,0-5,0	319

\* Other voltages available



Diamond Europe s.a./n.v.

92 Chaussée de Vilvorde  
92 Vilvoordsesteenweg  
1120 Brussels  
Belgium

info@diamond-eu.com  
Phone: +32 2 420 26 26  
Fax: +32 2 420 67 66  
www.diamond-europe.com